



Dachau

**GROSSE KREISSTADT  
DACHAU**

**Verkehrserhebungen**

**2007**

- Ergebnisse -



Stand: Juli 2007

Richard-Strauss-Str. 32  
82152 Planegg

**I N G E V O S T**  
Dipl.-Ing. Christian Fahnberg

Stadt Dachau

Verkehrszählungen 2007

Zählzeit: 06:00 Uhr - 10:00 Uhr und 15:00 Uhr - 19:00 Uhr

Knotenpunkt	Zähltag				
	Do. 26.10.06	Di. 19.04.07	Di. 24.04.07	Do. 26.04.07	Do. 21.06.07
K1 Augsburgener Straße / Weblinger Weg		X			
K2 Freisinger Straße / Weblinger Weg		X			
K3 Augsburgener Straße / Dr.-Hiller-Straße		X			
K4 Augsburgener Straße / Mittermayerstraße		X			
K5 Ludwig-Thoma-Straße / Mittermayerstraße		X			
K6 Brucker Straße / Abzweig Einsbach		X			
K8 Ludwig-Thoma-Straße / Ostenstraße		X			
K9 Ludwig-Thoma-Straße / Martin-Huber-Straße		X			
K10 Ludwig-Thoma-Straße / Karlsberg			X		
K11 Augsburgener Straße / Karlsberg			X		
K12 Gröbenrieder Straße / Himmelreichweg			X		
K13 Gröbenrieder Straße / Eduard-Ziegler-Straße			X		
K14 Gröbenrieder Straße / Emmeringer Straße			X		
K15 Langwieder Straße / Emmeringer Straße			X		
K16 Münchener Straße / Anton-Hechtl-Straße			X		
K17 Münchener Straße / Goethestraße			X		
K18 Münchener Straße / Bahnhofstraße			X		
K19 Münchener Straße / Gröbenreider Straße			X		
K20 Münchener Straße / Schleißheimer Straße			X		
K21 Schleißheimer Straße / Frühlingstraße				X	
K22 Schleißheimer Straße / Pollnstraße				X	
K23 Schleißheimer Straße / Würmstraße	X				
K24 Schleißheimer Straße / Kopernikusstraße	X				
K25 Alte Römerstraße / Sudetenlandstraße				X	
K26 Alte Römerstraße / Rudolf-Diesel-Straße				X	
K27 Alte Römerstraße / Pater-Roth-Straße				X	
K28 ST2339 / Alte Römerstraße				X	
K29 Augustenfelder Straße / Obere Mooschwaigstraße				X	
K30 Sudetenlandstraße / Theodor-Heuss-Straße				X	
K31 Theodor-Heuss-Straße / Wallbergstraße				X	
K32 Wallberstraße / Augustenfelder Straße				X	
K33 Münchener Straße / Wallbergstraße				X	
K41 Freisinger Straße / Erich-Ollenhauer-Straße					X
K42 Augsburgener Straße / Bürgermeister-Zauner-Ring					X
K43 Theodor-Heuss-Straße / Schleißheimer Straße	X				
K44 Schleißheimer Straße / Alte-Römer-Straße	X				
K45 Ludwig-Thoma-Straße / Konrad-Adenauer-Straße					X
K46 Erich-Ollenhauer-Straße / Friedenstraße					X
K47 Brucker Straße / Ludwig-Dill-Straße					X
K48 Freisinger Straße / Konrad-Adenauer-Straße					X



# Stadt Dachau

Zählstelle: K1 Augsburgs Straße / Weblinger Weg

Zu-/Ablauf 1: Weblinger Weg

Zu-/Ablauf 2: Augsburgs Str. (von/nach Stadtinwärts)

Zu-/Ablauf 3: Augsburgs Str. (von/nach Stadtauswärts)

Zusammenfassung Stundengruppen

Zähltag: Di., 19.04.2007

Zählzeit: 06:00 Uhr - 10:00 Uhr und 15:00 Uhr - 19:00 Uhr

## Summe Zählzeit (06:00 Uhr - 10:00 Uhr und 15:00 Uhr - 19:00 Uhr)

FZ-ART	1-2	1-3	1-4	2-1	2-3	2-4	3-1	3-2	3-4	4-1	4-2	4-3	Zu. 1	Zu. 2	Zu. 3	Zu. 4	Ab. 1	Ab. 2	Ab. 3	Ab. 4	K-Sum
RAD	0	6	0	1	19	0	2	35	0	0	0	0	6	20	37	0	3	35	25	0	63
KRAD	4	53	0	6	77	0	48	79	0	0	0	0	57	83	127	0	54	83	130	0	267
PKW	155	1815	0	200	3623	0	1852	4011	0	0	0	0	1970	3823	5863	0	2052	4166	5438	0	11656
BUS	1	10	0	1	21	0	16	31	0	0	0	0	11	22	47	0	17	32	31	0	80
LFW	9	93	0	13	181	0	92	257	0	0	0	0	102	194	349	0	105	266	274	0	645
LKW	24	69	0	18	78	0	69	76	0	0	0	0	93	96	145	0	87	100	147	0	334
LZ	25	38	0	32	40	0	43	43	0	0	0	0	63	72	86	0	75	68	78	0	221
<b>KFZ</b>	<b>218</b>	<b>2078</b>	<b>0</b>	<b>270</b>	<b>4020</b>	<b>0</b>	<b>2120</b>	<b>4497</b>	<b>0</b>	<b>0</b>	<b>0</b>	<b>0</b>	<b>2296</b>	<b>4290</b>	<b>6617</b>	<b>0</b>	<b>2390</b>	<b>4715</b>	<b>6098</b>	<b>0</b>	<b>13203</b>
SV	50	117	0	51	139	0	128	150	0	0	0	0	167	190	278	0	179	200	256	0	635
PV	160	1878	0	207	3721	0	1916	4121	0	0	0	0	2038	3928	6037	0	2123	4281	5599	0	12003
GV	58	200	0	63	299	0	204	376	0	0	0	0	258	362	580	0	267	434	499	0	1200
<b>FZ-ART</b>	<b>1-2</b>	<b>1-3</b>	<b>1-4</b>	<b>2-1</b>	<b>2-3</b>	<b>2-4</b>	<b>3-1</b>	<b>3-2</b>	<b>3-4</b>	<b>4-1</b>	<b>4-2</b>	<b>4-3</b>	<b>Zu. 1</b>	<b>Zu. 2</b>	<b>Zu. 3</b>	<b>Zu. 4</b>	<b>Ab. 1</b>	<b>Ab. 2</b>	<b>Ab. 3</b>	<b>Ab. 4</b>	<b>K-Sum</b>

## Summe Zählintervall 06:00 Uhr - 10:00 Uhr

FZ-ART	1-2	1-3	1-4	2-1	2-3	2-4	3-1	3-2	3-4	4-1	4-2	4-3	Zu. 1	Zu. 2	Zu. 3	Zu. 4	Ab. 1	Ab. 2	Ab. 3	Ab. 4	K-Sum
RAD	0	0	0	0	5	0	1	15	0	0	0	0	0	5	16	0	1	15	5	0	21
KRAD	1	5	0	2	6	0	31	38	0	0	0	0	6	8	69	0	33	39	11	0	83
PKW	95	293	0	74	766	0	1253	2784	0	0	0	0	388	840	4037	0	1327	2879	1059	0	5265
BUS	1	6	0	1	13	0	13	20	0	0	0	0	7	14	33	0	14	21	19	0	54
LFW	5	32	0	6	63	0	69	186	0	0	0	0	37	69	255	0	75	191	95	0	361
LKW	14	28	0	8	36	0	46	50	0	0	0	0	42	44	96	0	54	64	64	0	182
LZ	13	16	0	25	23	0	27	26	0	0	0	0	29	48	53	0	52	39	39	0	130
<b>KFZ</b>	<b>129</b>	<b>380</b>	<b>0</b>	<b>116</b>	<b>907</b>	<b>0</b>	<b>1439</b>	<b>3104</b>	<b>0</b>	<b>0</b>	<b>0</b>	<b>0</b>	<b>509</b>	<b>1023</b>	<b>4543</b>	<b>0</b>	<b>1555</b>	<b>3233</b>	<b>1287</b>	<b>0</b>	<b>6075</b>
SV	28	50	0	34	72	0	86	96	0	0	0	0	78	106	182	0	120	124	122	0	366
PV	97	304	0	77	785	0	1297	2842	0	0	0	0	401	862	4139	0	1374	2939	1089	0	5402
GV	32	76	0	39	122	0	142	262	0	0	0	0	108	161	404	0	181	294	198	0	673
<b>FZ-ART</b>	<b>1-2</b>	<b>1-3</b>	<b>1-4</b>	<b>2-1</b>	<b>2-3</b>	<b>2-4</b>	<b>3-1</b>	<b>3-2</b>	<b>3-4</b>	<b>4-1</b>	<b>4-2</b>	<b>4-3</b>	<b>Zu. 1</b>	<b>Zu. 2</b>	<b>Zu. 3</b>	<b>Zu. 4</b>	<b>Ab. 1</b>	<b>Ab. 2</b>	<b>Ab. 3</b>	<b>Ab. 4</b>	<b>K-Sum</b>

## Summe Zählintervall 15:00 Uhr - 19:00 Uhr

FZ-ART	1-2	1-3	1-4	2-1	2-3	2-4	3-1	3-2	3-4	4-1	4-2	4-3	Zu. 1	Zu. 2	Zu. 3	Zu. 4	Ab. 1	Ab. 2	Ab. 3	Ab. 4	K-Sum
RAD	0	6	0	1	14	0	1	20	0	0	0	0	6	15	21	0	2	20	20	0	42
KRAD	3	48	0	4	71	0	17	41	0	0	0	0	51	75	58	0	21	44	119	0	184
PKW	60	1522	0	126	2857	0	599	1227	0	0	0	0	1582	2983	1826	0	725	1287	4379	0	6391
BUS	0	4	0	0	8	0	3	11	0	0	0	0	4	8	14	0	3	11	12	0	26
LFW	4	61	0	7	118	0	23	71	0	0	0	0	65	125	94	0	30	75	179	0	284
LKW	10	41	0	10	42	0	23	26	0	0	0	0	51	52	49	0	33	36	83	0	152
LZ	12	22	0	7	17	0	16	17	0	0	0	0	34	24	33	0	23	29	39	0	91
<b>KFZ</b>	<b>89</b>	<b>1698</b>	<b>0</b>	<b>154</b>	<b>3113</b>	<b>0</b>	<b>681</b>	<b>1393</b>	<b>0</b>	<b>0</b>	<b>0</b>	<b>0</b>	<b>1787</b>	<b>3267</b>	<b>2074</b>	<b>0</b>	<b>835</b>	<b>1482</b>	<b>4811</b>	<b>0</b>	<b>7128</b>
SV	22	67	0	17	67	0	42	54	0	0	0	0	89	84	96	0	59	76	134	0	269
PV	63	1574	0	130	2936	0	619	1279	0	0	0	0	1637	3066	1898	0	749	1342	4510	0	6601
GV	26	124	0	24	177	0	62	114	0	0	0	0	150	201	176	0	86	140	301	0	527
<b>FZ-ART</b>	<b>1-2</b>	<b>1-3</b>	<b>1-4</b>	<b>2-1</b>	<b>2-3</b>	<b>2-4</b>	<b>3-1</b>	<b>3-2</b>	<b>3-4</b>	<b>4-1</b>	<b>4-2</b>	<b>4-3</b>	<b>Zu. 1</b>	<b>Zu. 2</b>	<b>Zu. 3</b>	<b>Zu. 4</b>	<b>Ab. 1</b>	<b>Ab. 2</b>	<b>Ab. 3</b>	<b>Ab. 4</b>	<b>K-Sum</b>

## spezifische Spitzenstunde morgens 07:00 Uhr - 08:00 Uhr

FZ-ART	1-2	1-3	1-4	2-1	2-3	2-4	3-1	3-2	3-4	4-1	4-2	4-3	Zu. 1	Zu. 2	Zu. 3	Zu. 4	Ab. 1	Ab. 2	Ab. 3	Ab. 4	K-Sum
RAD	0	0	0	0	2	0	0	11	0	0	0	0	0	2	11	0	0	11	2	0	13
KRAD	1	1	0	0	1	0	14	16	0	0	0	0	2	1	30	0	14	17	2	0	33
PKW	23	93	0	16	184	0	399	989	0	0	0	0	116	200	1388	0	415	1012	277	0	1704
BUS	1	2	0	0	5	0	3	12	0	0	0	0	3	5	15	0	3	13	7	0	23
LFW	1	12	0	0	16	0	18	52	0	0	0	0	13	16	70	0	18	53	28	0	99
LKW	1	12	0	1	8	0	8	12	0	0	0	0	13	9	20	0	9	13	20	0	42
LZ	0	3	0	7	8	0	8	11	0	0	0	0	3	15	19	0	15	11	11	0	37
<b>KFZ</b>	<b>27</b>	<b>123</b>	<b>0</b>	<b>24</b>	<b>222</b>	<b>0</b>	<b>450</b>	<b>1092</b>	<b>0</b>	<b>0</b>	<b>0</b>	<b>0</b>	<b>150</b>	<b>246</b>	<b>1542</b>	<b>0</b>	<b>474</b>	<b>1119</b>	<b>345</b>	<b>0</b>	<b>1938</b>
SV	2	17	0	8	21	0	19	35	0	0	0	0	19	29	54	0	27	37	38	0	102
PV	25	96	0	16	190	0	416	1017	0	0	0	0	121	206	1433	0	432	1042	286	0	1760
GV	2	27	0	8	32	0	34	75	0	0	0	0	29	40	109	0	42	77	59	0	178
<b>FZ-ART</b>	<b>1-2</b>	<b>1-3</b>	<b>1-4</b>	<b>2-1</b>	<b>2-3</b>	<b>2-4</b>	<b>3-1</b>	<b>3-2</b>	<b>3-4</b>	<b>4-1</b>	<b>4-2</b>	<b>4-3</b>	<b>Zu. 1</b>	<b>Zu. 2</b>	<b>Zu. 3</b>	<b>Zu. 4</b>	<b>Ab. 1</b>	<b>Ab. 2</b>	<b>Ab. 3</b>	<b>Ab. 4</b>	<b>K-Sum</b>

## spezifische Spitzenstunde abends 16:45 Uhr - 17:45 Uhr

FZ-ART	1-2	1-3	1-4	2-1	2-3	2-4	3-1	3-2	3-4	4-1	4-2	4-3	Zu. 1	Zu. 2	Zu. 3	Zu. 4	Ab. 1	Ab. 2	Ab. 3	Ab. 4	K-Sum
RAD	0	2	0	0	4	0	0	4	0	0	0	0	2	4	4	0	0	4	6	0	10
KRAD	1	12	0	2	15	0	3	11	0	0	0	0	13	17	14	0	5	12	27	0	44
PKW	18	379	0	38	790	0	160	316	0	0	0	0	397	828	476	0	198	334	1169	0	1701
BUS	0	2	0	0	1	0	1	5	0	0	0	0	2	1	6	0	1	5	3	0	9
LFW	1	17	0	1	48	0	7	19	0	0	0	0	18	49	26	0	8	20	65	0	93
LKW	0	10	0																		

# Stadt Dachau

Zählstelle: K1 Augsburgener Straße / Weblinger Weg

Zusammenfassung Stundengruppen

Zähltag: Di., 19.04.2007

Zu-/Ablauf 1: Weblinger Weg

Zu-/Ablauf 2: Augsburgener Str. (von/nach Stadteinwärts)

Zu-/Ablauf 3: Augsburgener Str. (von/nach Stadtauswärts)

Spezifische Spitzenstunde morgens  
07:00 Uhr - 08:00 Uhr in KFZ

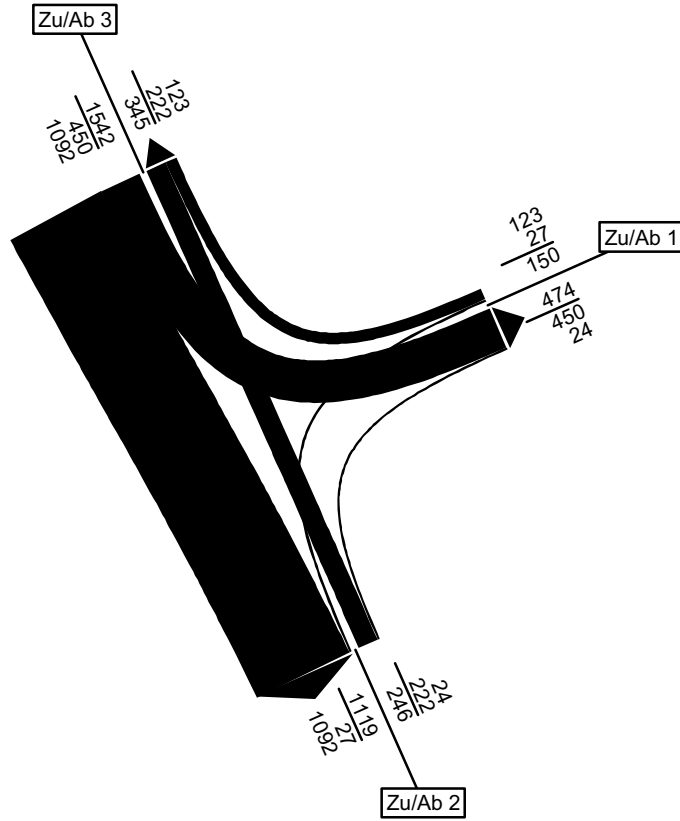

Spezifische Spitzenstunde abends  
16:45 Uhr - 17:45 Uhr in KFZ

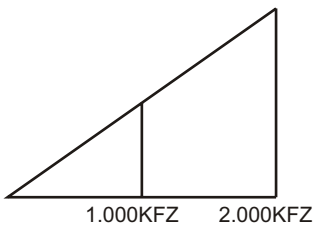
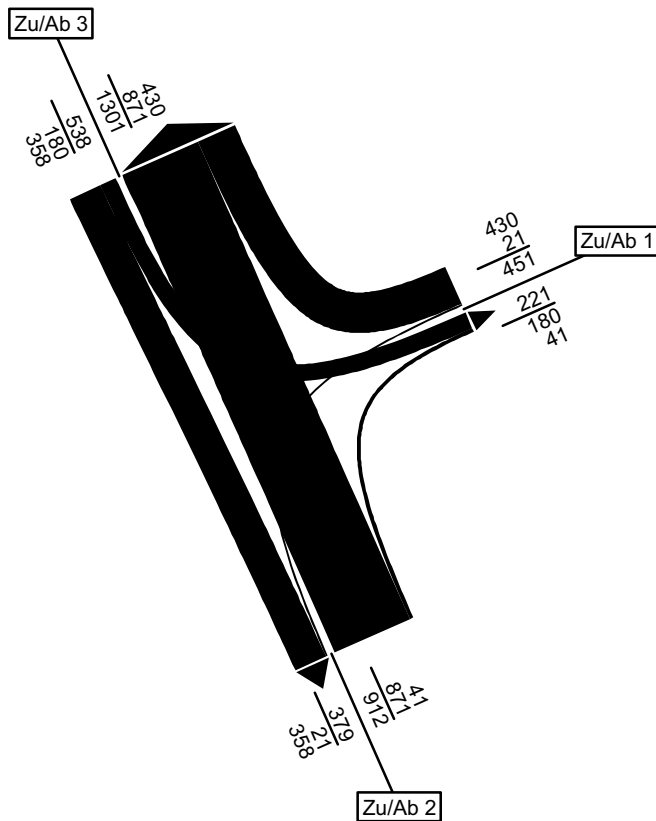

**Stadt Dachau**

Zählstelle: K2 Freisinger Straße / Weblinger Weg

Zu-/Ablauf 1: Freisinger Str. (von/nach stadtauswärts)

Zu-/Ablauf 2: Freisinger Str. (von/nach stadteinwärts)

Zu-/Ablauf 3: Weblinger Weg

Zusammenfassung Stundengruppen

Zähltag: Di., 19.04.2007

Zählzeit: 06:00 Uhr - 10:00 Uhr und 15:00 Uhr - 19:00 Uhr

**Summe Zähizeit (06:00 Uhr - 10:00 Uhr und 15:00 Uhr - 19:00 Uhr)**

FZ-ART	1-2	1-3	1-4	2-1	2-3	2-4	3-1	3-2	3-4	4-1	4-2	4-3	Zu. 1	Zu. 2	Zu. 3	Zu. 4	Ab. 1	Ab. 2	Ab. 3	Ab. 4	K-Sum
RAD	60	31	0	78	38	0	25	54	0	0	0	0	91	116	79	0	103	114	69	0	286
KRAD	55	11	0	39	42	0	13	44	0	0	0	0	66	81	57	0	52	99	53	0	204
PKW	2002	397	0	1764	1666	0	498	1580	0	0	0	0	2399	3430	2078	0	2262	3582	2063	0	7907
BUS	85	0	0	8	6	0	2	50	0	0	0	0	85	14	52	0	10	135	6	0	151
LFW	151	36	0	155	86	0	48	94	0	0	0	0	187	241	142	0	203	245	122	0	570
LKW	29	23	0	38	56	0	29	33	0	0	0	0	52	94	62	0	67	62	79	0	208
LZ	28	24	0	17	32	0	21	41	0	0	0	0	52	49	62	0	38	69	56	0	163
<b>KFZ</b>	<b>2350</b>	<b>491</b>	<b>0</b>	<b>2021</b>	<b>1888</b>	<b>0</b>	<b>611</b>	<b>1842</b>	<b>0</b>	<b>0</b>	<b>0</b>	<b>0</b>	<b>2841</b>	<b>3909</b>	<b>2453</b>	<b>0</b>	<b>2632</b>	<b>4192</b>	<b>2379</b>	<b>0</b>	<b>9203</b>
SV	142	47	0	63	94	0	52	124	0	0	0	0	189	157	176	0	115	266	141	0	522
PV	2142	408	0	1811	1714	0	513	1674	0	0	0	0	2550	3525	2187	0	2324	3816	2122	0	8262
GV	208	83	0	210	174	0	98	168	0	0	0	0	291	384	266	0	308	376	257	0	941
<b>FZ-ART</b>	<b>1-2</b>	<b>1-3</b>	<b>1-4</b>	<b>2-1</b>	<b>2-3</b>	<b>2-4</b>	<b>3-1</b>	<b>3-2</b>	<b>3-4</b>	<b>4-1</b>	<b>4-2</b>	<b>4-3</b>	<b>Zu. 1</b>	<b>Zu. 2</b>	<b>Zu. 3</b>	<b>Zu. 4</b>	<b>Ab. 1</b>	<b>Ab. 2</b>	<b>Ab. 3</b>	<b>Ab. 4</b>	<b>K-Sum</b>

**Summe Zählintervall 06:00 Uhr - 10:00 Uhr**

FZ-ART	1-2	1-3	1-4	2-1	2-3	2-4	3-1	3-2	3-4	4-1	4-2	4-3	Zu. 1	Zu. 2	Zu. 3	Zu. 4	Ab. 1	Ab. 2	Ab. 3	Ab. 4	K-Sum
RAD	36	5	0	14	7	0	5	17	0	0	0	0	41	21	22	0	19	53	12	0	84
KRAD	16	0	0	6	6	0	8	26	0	0	0	0	16	12	34	0	14	42	6	0	62
PKW	1027	54	0	605	281	0	339	1015	0	0	0	0	1081	886	1354	0	944	2042	335	0	3321
BUS	48	0	0	5	3	0	1	34	0	0	0	0	48	8	35	0	6	82	3	0	91
LFW	99	11	0	77	27	0	29	64	0	0	0	0	110	104	93	0	106	163	38	0	307
LKW	21	12	0	22	24	0	19	23	0	0	0	0	33	46	42	0	41	44	36	0	121
LZ	24	13	0	12	18	0	15	26	0	0	0	0	37	30	41	0	27	50	31	0	108
<b>KFZ</b>	<b>1235</b>	<b>90</b>	<b>0</b>	<b>727</b>	<b>359</b>	<b>0</b>	<b>411</b>	<b>1188</b>	<b>0</b>	<b>0</b>	<b>0</b>	<b>0</b>	<b>1325</b>	<b>1086</b>	<b>1599</b>	<b>0</b>	<b>1138</b>	<b>2423</b>	<b>449</b>	<b>0</b>	<b>4010</b>
SV	93	25	0	39	45	0	35	83	0	0	0	0	118	84	118	0	74	176	70	0	320
PV	1091	54	0	616	290	0	348	1075	0	0	0	0	1145	906	1423	0	964	2166	344	0	3474
GV	144	36	0	111	69	0	63	113	0	0	0	0	180	180	176	0	174	257	105	0	536
<b>FZ-ART</b>	<b>1-2</b>	<b>1-3</b>	<b>1-4</b>	<b>2-1</b>	<b>2-3</b>	<b>2-4</b>	<b>3-1</b>	<b>3-2</b>	<b>3-4</b>	<b>4-1</b>	<b>4-2</b>	<b>4-3</b>	<b>Zu. 1</b>	<b>Zu. 2</b>	<b>Zu. 3</b>	<b>Zu. 4</b>	<b>Ab. 1</b>	<b>Ab. 2</b>	<b>Ab. 3</b>	<b>Ab. 4</b>	<b>K-Sum</b>

**Summe Zählintervall 15:00 Uhr - 19:00 Uhr**

FZ-ART	1-2	1-3	1-4	2-1	2-3	2-4	3-1	3-2	3-4	4-1	4-2	4-3	Zu. 1	Zu. 2	Zu. 3	Zu. 4	Ab. 1	Ab. 2	Ab. 3	Ab. 4	K-Sum
RAD	24	26	0	64	31	0	20	37	0	0	0	0	50	95	57	0	84	61	57	0	202
KRAD	39	11	0	33	36	0	5	18	0	0	0	0	50	69	23	0	38	57	47	0	142
PKW	975	343	0	1159	1385	0	159	565	0	0	0	0	1318	2544	724	0	1318	1540	1728	0	4586
BUS	37	0	0	3	3	0	1	16	0	0	0	0	37	6	17	0	4	53	3	0	60
LFW	52	25	0	78	59	0	19	30	0	0	0	0	77	137	49	0	97	82	84	0	263
LKW	8	11	0	16	32	0	10	10	0	0	0	0	19	48	20	0	26	18	43	0	87
LZ	4	11	0	5	14	0	6	15	0	0	0	0	15	19	21	0	11	19	25	0	55
<b>KFZ</b>	<b>1115</b>	<b>401</b>	<b>0</b>	<b>1294</b>	<b>1529</b>	<b>0</b>	<b>200</b>	<b>654</b>	<b>0</b>	<b>0</b>	<b>0</b>	<b>0</b>	<b>1516</b>	<b>2823</b>	<b>854</b>	<b>0</b>	<b>1494</b>	<b>1769</b>	<b>1930</b>	<b>0</b>	<b>5193</b>
SV	49	22	0	24	49	0	17	41	0	0	0	0	71	73	58	0	41	90	71	0	202
PV	1051	354	0	1195	1424	0	165	599	0	0	0	0	1405	2619	764	0	1360	1650	1778	0	4788
GV	64	47	0	99	105	0	35	55	0	0	0	0	111	204	90	0	134	119	152	0	405
<b>FZ-ART</b>	<b>1-2</b>	<b>1-3</b>	<b>1-4</b>	<b>2-1</b>	<b>2-3</b>	<b>2-4</b>	<b>3-1</b>	<b>3-2</b>	<b>3-4</b>	<b>4-1</b>	<b>4-2</b>	<b>4-3</b>	<b>Zu. 1</b>	<b>Zu. 2</b>	<b>Zu. 3</b>	<b>Zu. 4</b>	<b>Ab. 1</b>	<b>Ab. 2</b>	<b>Ab. 3</b>	<b>Ab. 4</b>	<b>K-Sum</b>

**spezifische Spitzenstunde morgens 07:15 Uhr - 08:15 Uhr**

FZ-ART	1-2	1-3	1-4	2-1	2-3	2-4	3-1	3-2	3-4	4-1	4-2	4-3	Zu. 1	Zu. 2	Zu. 3	Zu. 4	Ab. 1	Ab. 2	Ab. 3	Ab. 4	K-Sum
RAD	15	1	0	3	0	0	1	4	0	0	0	0	16	3	5	0	4	19	1	0	24
KRAD	5	0	0	1	1	0	0	10	0	0	0	0	5	2	10	0	1	15	1	0	17
PKW	433	14	0	195	78	0	109	307	0	0	0	0	447	273	416	0	304	740	92	0	1136
BUS	17	0	0	4	2	0	1	14	0	0	0	0	17	6	15	0	5	31	2	0	38
LFW	36	2	0	28	7	0	8	12	0	0	0	0	38	35	20	0	36	48	9	0	93
LKW	3	4	0	5	12	0	6	7	0	0	0	0	7	17	13	0	11	10	16	0	37
LZ	6	4	0	3	5	0	4	10	0	0	0	0	10	8	14	0	7	16	9	0	32
<b>KFZ</b>	<b>500</b>	<b>24</b>	<b>0</b>	<b>236</b>	<b>105</b>	<b>0</b>	<b>128</b>	<b>360</b>	<b>0</b>	<b>0</b>	<b>0</b>	<b>0</b>	<b>524</b>	<b>341</b>	<b>488</b>	<b>0</b>	<b>364</b>	<b>860</b>	<b>129</b>	<b>0</b>	<b>1353</b>
SV	26	8	0	12	19	0	11	31	0	0	0	0	34	31	42	0	23	57	27	0	107
PV	455	14	0	200	81	0	110	331	0	0	0	0	469	281	441	0	310	786	95	0	1191
GV	45	10	0	36	24	0	18	29	0	0	0	0	55	60	47	0	54	74	34	0	162
<b>FZ-ART</b>	<b>1-2</b>	<b>1-3</b>	<b>1-4</b>	<b>2-1</b>	<b>2-3</b>	<b>2-4</b>	<b>3-1</b>	<b>3-2</b>	<b>3-4</b>	<b>4-1</b>	<b>4-2</b>	<b>4-3</b>	<b>Zu. 1</b>	<b>Zu. 2</b>	<b>Zu. 3</b>	<b>Zu. 4</b>	<b>Ab. 1</b>	<b>Ab. 2</b>	<b>Ab. 3</b>	<b>Ab. 4</b>	<b>K-Sum</b>

**spezifische Spitzenstunde abends 16:30 Uhr - 17:30 Uhr**

FZ-ART	1-2	1-3	1-4	2-1	2-3	2-4	3-1	3-2	3-4	4-1	4-2	4-3	Zu. 1	Zu. 2	Zu. 3	Zu. 4	Ab. 1	Ab. 2	Ab. 3	Ab. 4	K-Sum
RAD	7	6	0	13	7	0	5	10	0	0	0	0	13	20	15	0	18	17	13	0	48
KRAD	10	1	0	10	11	0	0	7	0	0	0	0	11	21	7	0	10	17	12	0	39
PKW	290	116	0	322	387	0	32	141	0	0	0	0	406	709	173	0	354	431	503	0	1288
BUS	8	0	0	1	0	0	1	6	0	0	0	0	8	1	7	0	5	14	0	0	16
LFW	12	7	0	25	16	0	3	8	0	0	0	0	19	41	11	0	28	20	23	0	71
LKW																					

# Stadt Dachau

Zählstelle: K2 Freisinger Straße / Weblinger Weg

Zusammenfassung Stundengruppen

Zähltag: Di., 19.04.2007

Zu-/Ablauf 1: Freisinger Str. (von/nach stadtauswärts)

Zu-/Ablauf 2: Freisinger Str. (von/nach stadteinwärts)

Zu-/Ablauf 3: Weblinger Weg

Spezifische Spitzenstunde morgens  
07:15 Uhr - 08:15 Uhr in KFZ

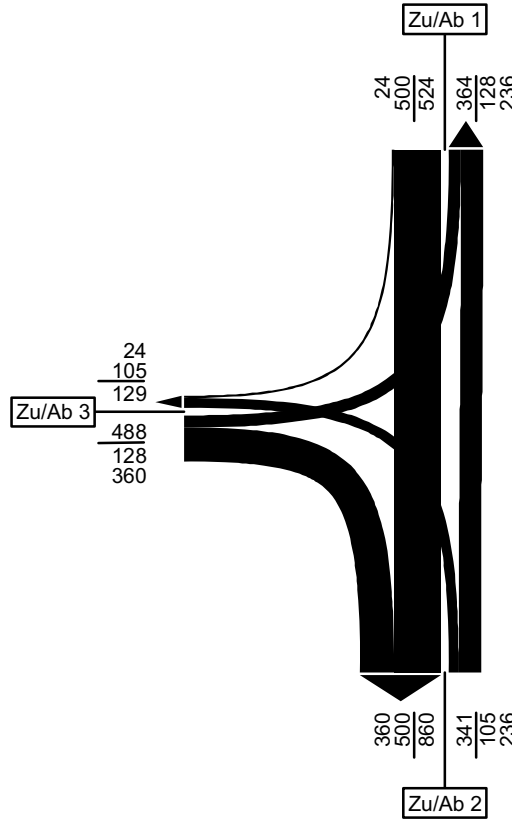

Spezifische Spitzenstunde abends  
16:30 Uhr - 17:30 Uhr in KFZ

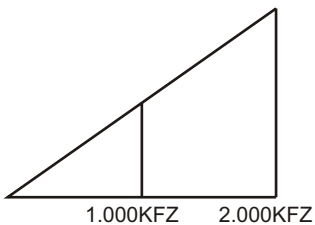
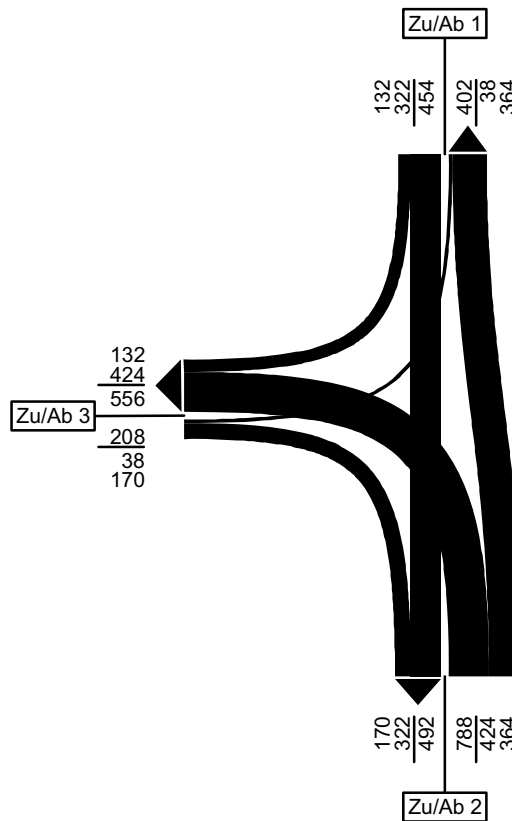

# Stadt Dachau

Zählstelle: K3 Augsburg Straße / Dr.-Hiller-Straße

Zu-/Ablauf 1: Dr.-Hiller-Str.

Zu-/Ablauf 2: Augsburg Str. (von/nach Stadtinwärts)

Zu-/Ablauf 3: Augsburg Str. (von/nach Stadtauswärts)

Zusammenfassung Stundengruppen

Zähltag: Di., 19.04.2007

Zählzeit: 06:00 Uhr - 10:00 Uhr und 15:00 Uhr - 19:00 Uhr

## Summe Zählzeit (06:00 Uhr - 10:00 Uhr und 15:00 Uhr - 19:00 Uhr)

FZ-ART	1-2	1-3	1-4	2-1	2-3	2-4	3-1	3-2	3-4	4-1	4-2	4-3	Zu. 1	Zu. 2	Zu. 3	Zu. 4	Ab. 1	Ab. 2	Ab. 3	Ab. 4	K-Sum
RAD	10	9	0	9	33	0	3	24	0	0	0	0	19	42	27	0	12	34	42	0	88
KRAD	6	6	0	6	79	0	10	77	0	0	0	0	12	85	87	0	16	83	85	0	184
PKW	434	326	0	328	3526	0	336	3893	0	0	0	0	760	3854	4229	0	664	4327	3852	0	8843
BUS	25	0	0	23	22	0	0	32	0	0	0	0	25	45	32	0	23	57	22	0	102
LFW	18	16	0	16	181	0	12	257	0	0	0	0	34	197	269	0	28	275	197	0	500
LKW	2	2	0	2	104	0	3	103	0	0	0	0	4	106	106	0	5	105	106	0	216
LZ	0	0	0	1	78	0	0	68	0	0	0	0	0	79	68	0	1	68	78	0	147
<b>KFZ</b>	<b>485</b>	<b>350</b>	<b>0</b>	<b>376</b>	<b>3990</b>	<b>0</b>	<b>361</b>	<b>4430</b>	<b>0</b>	<b>0</b>	<b>0</b>	<b>0</b>	<b>835</b>	<b>4366</b>	<b>4791</b>	<b>0</b>	<b>737</b>	<b>4915</b>	<b>4340</b>	<b>0</b>	<b>9992</b>
SV	27	2	0	26	204	0	3	203	0	0	0	0	29	230	206	0	29	230	206	0	465
PV	465	332	0	357	3627	0	346	4002	0	0	0	0	797	3984	4348	0	703	4467	3959	0	9129
GV	20	18	0	19	363	0	15	428	0	0	0	0	38	382	443	0	34	448	381	0	863
<b>FZ-ART</b>	<b>1-2</b>	<b>1-3</b>	<b>1-4</b>	<b>2-1</b>	<b>2-3</b>	<b>2-4</b>	<b>3-1</b>	<b>3-2</b>	<b>3-4</b>	<b>4-1</b>	<b>4-2</b>	<b>4-3</b>	<b>Zu. 1</b>	<b>Zu. 2</b>	<b>Zu. 3</b>	<b>Zu. 4</b>	<b>Ab. 1</b>	<b>Ab. 2</b>	<b>Ab. 3</b>	<b>Ab. 4</b>	<b>K-Sum</b>

## Summe Zählintervall 06:00 Uhr - 10:00 Uhr

FZ-ART	1-2	1-3	1-4	2-1	2-3	2-4	3-1	3-2	3-4	4-1	4-2	4-3	Zu. 1	Zu. 2	Zu. 3	Zu. 4	Ab. 1	Ab. 2	Ab. 3	Ab. 4	K-Sum
RAD	0	1	0	5	4	0	0	9	0	0	0	0	1	9	9	0	5	9	5	0	19
KRAD	2	1	0	6	10	0	5	37	0	0	0	0	3	16	42	0	11	39	11	0	61
PKW	167	86	0	142	770	0	221	2691	0	0	0	0	253	912	2912	0	363	2858	856	0	4077
BUS	13	0	0	11	14	0	0	21	0	0	0	0	13	25	21	0	11	34	14	0	59
LFW	11	9	0	12	60	0	9	180	0	0	0	0	20	72	189	0	21	191	69	0	281
LKW	1	2	0	0	48	0	2	66	0	0	0	0	3	48	68	0	2	67	50	0	119
LZ	0	0	0	1	50	0	0	39	0	0	0	0	0	51	39	0	1	39	50	0	90
<b>KFZ</b>	<b>194</b>	<b>98</b>	<b>0</b>	<b>172</b>	<b>952</b>	<b>0</b>	<b>237</b>	<b>3034</b>	<b>0</b>	<b>0</b>	<b>0</b>	<b>0</b>	<b>292</b>	<b>1124</b>	<b>3271</b>	<b>0</b>	<b>409</b>	<b>3228</b>	<b>1050</b>	<b>0</b>	<b>4687</b>
SV	14	2	0	12	112	0	2	126	0	0	0	0	16	124	128	0	14	140	114	0	288
PV	182	87	0	159	794	0	226	2749	0	0	0	0	269	953	2975	0	385	2931	881	0	4197
GV	12	11	0	13	158	0	11	285	0	0	0	0	23	171	296	0	24	297	169	0	490
<b>FZ-ART</b>	<b>1-2</b>	<b>1-3</b>	<b>1-4</b>	<b>2-1</b>	<b>2-3</b>	<b>2-4</b>	<b>3-1</b>	<b>3-2</b>	<b>3-4</b>	<b>4-1</b>	<b>4-2</b>	<b>4-3</b>	<b>Zu. 1</b>	<b>Zu. 2</b>	<b>Zu. 3</b>	<b>Zu. 4</b>	<b>Ab. 1</b>	<b>Ab. 2</b>	<b>Ab. 3</b>	<b>Ab. 4</b>	<b>K-Sum</b>

## Summe Zählintervall 15:00 Uhr - 19:00 Uhr

FZ-ART	1-2	1-3	1-4	2-1	2-3	2-4	3-1	3-2	3-4	4-1	4-2	4-3	Zu. 1	Zu. 2	Zu. 3	Zu. 4	Ab. 1	Ab. 2	Ab. 3	Ab. 4	K-Sum
RAD	10	8	0	4	29	0	3	15	0	0	0	0	18	33	18	0	7	25	37	0	69
KRAD	4	5	0	0	69	0	5	40	0	0	0	0	9	69	45	0	5	44	74	0	123
PKW	267	240	0	186	2756	0	115	1202	0	0	0	0	507	2942	1317	0	301	1469	2996	0	4766
BUS	12	0	0	12	8	0	0	11	0	0	0	0	12	20	11	0	12	23	8	0	43
LFW	7	7	0	4	121	0	3	77	0	0	0	0	14	125	80	0	7	84	128	0	219
LKW	1	0	0	2	56	0	1	37	0	0	0	0	1	58	38	0	3	38	56	0	97
LZ	0	0	0	0	28	0	0	29	0	0	0	0	0	28	29	0	0	29	28	0	57
<b>KFZ</b>	<b>291</b>	<b>252</b>	<b>0</b>	<b>204</b>	<b>3038</b>	<b>0</b>	<b>124</b>	<b>1396</b>	<b>0</b>	<b>0</b>	<b>0</b>	<b>0</b>	<b>543</b>	<b>3242</b>	<b>1520</b>	<b>0</b>	<b>328</b>	<b>1687</b>	<b>3290</b>	<b>0</b>	<b>5305</b>
SV	13	0	0	14	92	0	1	77	0	0	0	0	13	106	78	0	15	90	92	0	197
PV	283	245	0	198	2833	0	120	1253	0	0	0	0	528	3031	1373	0	318	1536	3078	0	4932
GV	8	7	0	6	205	0	4	143	0	0	0	0	15	211	147	0	10	151	212	0	373
<b>FZ-ART</b>	<b>1-2</b>	<b>1-3</b>	<b>1-4</b>	<b>2-1</b>	<b>2-3</b>	<b>2-4</b>	<b>3-1</b>	<b>3-2</b>	<b>3-4</b>	<b>4-1</b>	<b>4-2</b>	<b>4-3</b>	<b>Zu. 1</b>	<b>Zu. 2</b>	<b>Zu. 3</b>	<b>Zu. 4</b>	<b>Ab. 1</b>	<b>Ab. 2</b>	<b>Ab. 3</b>	<b>Ab. 4</b>	<b>K-Sum</b>

## spezifische Spitzenstunde morgens 07:15 Uhr - 08:15 Uhr

FZ-ART	1-2	1-3	1-4	2-1	2-3	2-4	3-1	3-2	3-4	4-1	4-2	4-3	Zu. 1	Zu. 2	Zu. 3	Zu. 4	Ab. 1	Ab. 2	Ab. 3	Ab. 4	K-Sum
RAD	0	0	0	1	2	0	0	4	0	0	0	0	0	3	4	0	1	4	2	0	7
KRAD	0	1	0	1	3	0	3	12	0	0	0	0	1	4	15	0	4	12	4	0	20
PKW	74	22	0	63	216	0	90	901	0	0	0	0	96	279	991	0	153	975	238	0	1366
BUS	3	0	0	3	5	0	0	11	0	0	0	0	3	8	11	0	3	14	5	0	22
LFW	2	3	0	6	15	0	3	40	0	0	0	0	5	21	43	0	9	42	18	0	69
LKW	0	0	0	0	14	0	0	14	0	0	0	0	0	14	14	0	0	14	14	0	28
LZ	0	0	0	0	18	0	0	7	0	0	0	0	0	18	7	0	0	7	18	0	25
<b>KFZ</b>	<b>79</b>	<b>26</b>	<b>0</b>	<b>73</b>	<b>271</b>	<b>0</b>	<b>96</b>	<b>985</b>	<b>0</b>	<b>0</b>	<b>0</b>	<b>0</b>	<b>105</b>	<b>344</b>	<b>1081</b>	<b>0</b>	<b>169</b>	<b>1064</b>	<b>297</b>	<b>0</b>	<b>1530</b>
SV	3	0	0	3	37	0	0	32	0	0	0	0	3	40	32	0	3	35	37	0	75
PV	77	23	0	67	224	0	93	924	0	0	0	0	100	291	1017	0	160	1001	247	0	1408
GV	2	3	0	6	47	0	3	61	0	0	0	0	5	53	64	0	9	63	50	0	122
<b>FZ-ART</b>	<b>1-2</b>	<b>1-3</b>	<b>1-4</b>	<b>2-1</b>	<b>2-3</b>	<b>2-4</b>	<b>3-1</b>	<b>3-2</b>	<b>3-4</b>	<b>4-1</b>	<b>4-2</b>	<b>4-3</b>	<b>Zu. 1</b>	<b>Zu. 2</b>	<b>Zu. 3</b>	<b>Zu. 4</b>	<b>Ab. 1</b>	<b>Ab. 2</b>	<b>Ab. 3</b>	<b>Ab. 4</b>	<b>K-Sum</b>

## spezifische Spitzenstunde abends 16:45 Uhr - 17:45 Uhr

FZ-ART	1-2	1-3	1-4	2-1	2-3	2-4	3-1	3-2	3-4	4-1	4-2	4-3	Zu. 1	Zu. 2	Zu. 3	Zu. 4	Ab. 1	Ab. 2	Ab. 3	Ab. 4	K-Sum
RAD	0	2	0	1	7	0	1	0	0	0	0	0	2	8	1	0	2	0	9	0	11
KRAD	0	2	0	0	18	0	1	11	0	0	0	0	2	18	12	0	1	11	20	0	32
PKW	71	63	0	49	770	0	39	297	0	0	0	0	134	819	336	0	88	368	833	0	1289
BUS	2	0	0	3	1	0	0	5	0	0	0	0	2	4	5	0	3	7	1	0	11
LFW	5	0	0	1	49	0	0	23	0	0	0	0	5	50	23	0	1	28	49	0	78
LKW	1	0	0	0	14	0	0	6	0	0	0	0	1	14	6	0	0	7	14	0	



# Stadt Dachau

Zählstelle: K3 Augsburger Straße / Dr.-Hiller-Straße

Zusammenfassung Stundengruppen

Zähltag: Di., 19.04.2007

Zu-/Ablauf 1: Dr.-Hiller-Str.

Zu-/Ablauf 2: Augsburger Str. (von/nach Stadteinwärts)

Zu-/Ablauf 3: Augsburger Str. (von/nach Stadtauswärts)

Spezifische Spitzenstunde morgens  
07:15 Uhr - 08:15 Uhr in KFZ

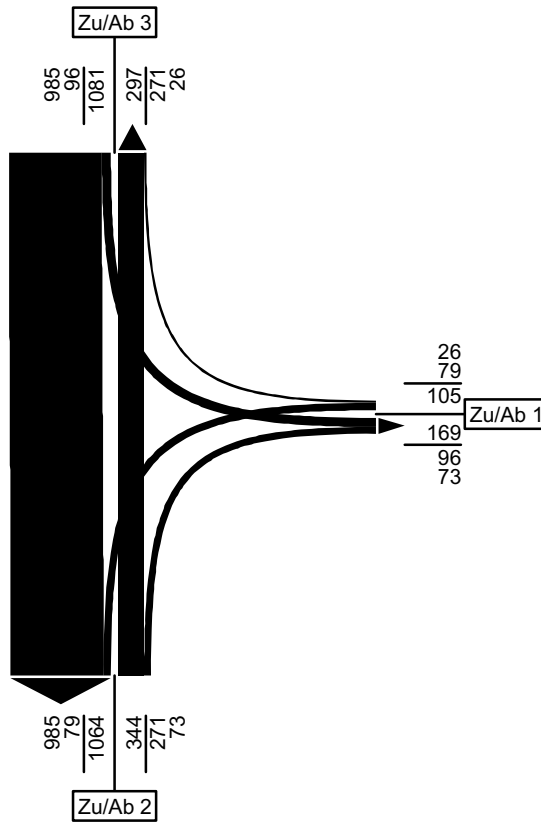

Spezifische Spitzenstunde abends  
16:45 Uhr - 17:45 Uhr in KFZ

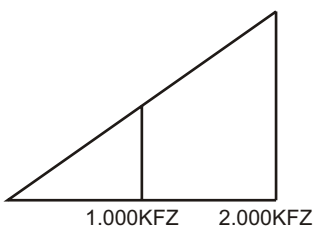
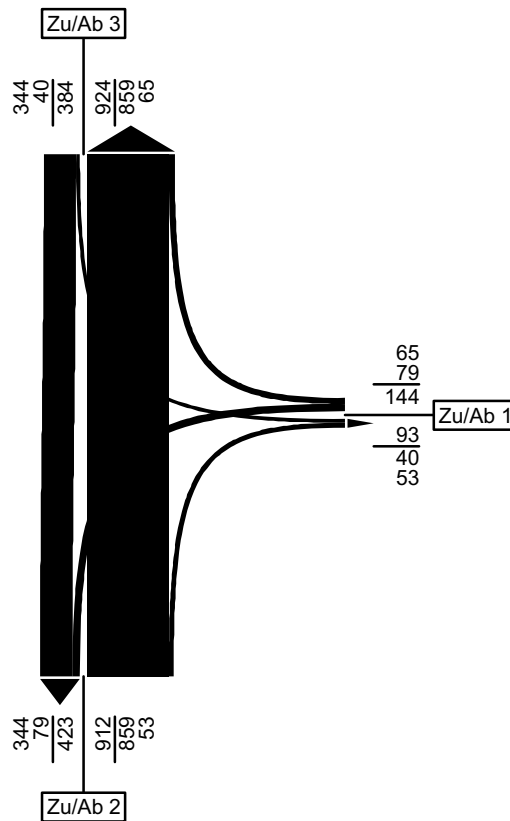

# Stadt Dachau

Zählstelle: K4 Augsburger Straße / Mittermayerstraße

Zu-/Ablauf 1: Mittermayerstr.  
 Zu-/Ablauf 2: Augsburger Str. (von/nach stadteinwärts)  
 Zu-/Ablauf 3: Augsburger Str. (von/nach stadtauswärts)  
 Zu-/Ablauf 4: Krankenhausstr.

Zusammenfassung Stundengruppen

Zähltag: Di., 19.04.2007

Zählzeit: 06:00 Uhr - 10:00 Uhr und 15:00 Uhr - 19:00 Uhr

## Summe Zählzeit (06:00 Uhr - 10:00 Uhr und 15:00 Uhr - 19:00 Uhr)

FZ-ART	1-2	1-3	1-4	2-1	2-3	2-4	3-1	3-2	3-4	4-1	4-2	4-3	Zu. 1	Zu. 2	Zu. 3	Zu. 4	Ab. 1	Ab. 2	Ab. 3	Ab. 4	K-Sum
RAD	33	34	61	65	3	7	134	13	4	31	20	7	128	75	151	56	230	66	44	72	412
KRAD	19	74	7	5	5	1	54	14	3	8	1	1	100	11	71	10	67	34	80	11	192
PKW	833	2848	686	552	268	80	2935	615	144	416	251	183	4367	900	3694	850	3903	1699	3299	910	9811
BUS	27	17	0	39	1	26	43	1	1	2	23	0	44	66	45	25	84	51	18	27	180
LFW	42	220	34	53	22	3	126	35	9	32	14	13	296	78	170	59	211	91	255	46	603
LKW	18	76	10	11	5	0	53	14	3	9	0	3	104	16	70	12	73	32	84	13	202
LZ	2	13	2	5	1	0	32	1	0	4	1	0	17	6	33	5	41	4	14	2	61
<b>KFZ</b>	<b>941</b>	<b>3248</b>	<b>739</b>	<b>665</b>	<b>302</b>	<b>110</b>	<b>3243</b>	<b>680</b>	<b>160</b>	<b>471</b>	<b>290</b>	<b>200</b>	<b>4928</b>	<b>1077</b>	<b>4083</b>	<b>961</b>	<b>4379</b>	<b>1911</b>	<b>3750</b>	<b>1009</b>	<b>11049</b>
SV	47	106	12	55	7	26	128	16	4	15	24	3	165	88	148	42	198	87	116	42	443
PV	879	2939	693	596	274	107	3032	630	148	426	275	184	4511	977	3810	885	4054	1784	3397	948	10183
GV	62	309	46	69	28	3	211	50	12	45	15	16	417	100	273	76	325	127	353	61	866
<b>FZ-ART</b>	<b>1-2</b>	<b>1-3</b>	<b>1-4</b>	<b>2-1</b>	<b>2-3</b>	<b>2-4</b>	<b>3-1</b>	<b>3-2</b>	<b>3-4</b>	<b>4-1</b>	<b>4-2</b>	<b>4-3</b>	<b>Zu. 1</b>	<b>Zu. 2</b>	<b>Zu. 3</b>	<b>Zu. 4</b>	<b>Ab. 1</b>	<b>Ab. 2</b>	<b>Ab. 3</b>	<b>Ab. 4</b>	<b>K-Sum</b>

## Summe Zählintervall 06:00 Uhr - 10:00 Uhr

FZ-ART	1-2	1-3	1-4	2-1	2-3	2-4	3-1	3-2	3-4	4-1	4-2	4-3	Zu. 1	Zu. 2	Zu. 3	Zu. 4	Ab. 1	Ab. 2	Ab. 3	Ab. 4	K-Sum
RAD	12	5	23	22	0	3	45	8	2	10	2	2	40	25	55	14	77	22	7	28	134
KRAD	7	2	2	5	3	1	19	8	2	4	1	0	11	9	29	5	28	16	5	5	54
PKW	373	864	299	254	68	29	1625	359	53	176	93	50	1536	351	2037	319	2055	825	982	381	4243
BUS	14	11	0	15	0	12	35	7	1	1	12	0	25	27	37	13	51	27	11	13	102
LFW	25	119	19	23	9	0	76	20	8	18	8	10	163	32	104	36	117	53	138	27	335
LKW	12	52	9	8	5	0	26	9	2	9	0	2	73	13	37	11	43	21	59	11	134
LZ	2	7	2	1	1	0	19	1	0	3	1	0	11	2	20	4	23	4	8	2	37
<b>KFZ</b>	<b>433</b>	<b>1055</b>	<b>331</b>	<b>306</b>	<b>86</b>	<b>42</b>	<b>1800</b>	<b>398</b>	<b>66</b>	<b>211</b>	<b>115</b>	<b>62</b>	<b>1819</b>	<b>434</b>	<b>2264</b>	<b>388</b>	<b>2317</b>	<b>946</b>	<b>1203</b>	<b>439</b>	<b>4905</b>
SV	28	70	11	24	6	12	80	11	3	13	13	2	109	42	94	28	117	52	78	26	273
PV	394	877	301	274	71	42	1679	368	56	181	106	50	1572	387	2103	337	2134	868	998	399	4399
GV	39	178	30	32	15	0	121	30	10	30	9	12	247	47	161	51	183	78	205	40	506
<b>FZ-ART</b>	<b>1-2</b>	<b>1-3</b>	<b>1-4</b>	<b>2-1</b>	<b>2-3</b>	<b>2-4</b>	<b>3-1</b>	<b>3-2</b>	<b>3-4</b>	<b>4-1</b>	<b>4-2</b>	<b>4-3</b>	<b>Zu. 1</b>	<b>Zu. 2</b>	<b>Zu. 3</b>	<b>Zu. 4</b>	<b>Ab. 1</b>	<b>Ab. 2</b>	<b>Ab. 3</b>	<b>Ab. 4</b>	<b>K-Sum</b>

## Summe Zählintervall 15:00 Uhr - 19:00 Uhr

FZ-ART	1-2	1-3	1-4	2-1	2-3	2-4	3-1	3-2	3-4	4-1	4-2	4-3	Zu. 1	Zu. 2	Zu. 3	Zu. 4	Ab. 1	Ab. 2	Ab. 3	Ab. 4	K-Sum
RAD	21	29	38	43	3	4	89	5	2	21	18	5	88	50	96	44	153	44	37	44	278
KRAD	12	72	5	0	2	0	35	6	1	4	0	1	89	2	42	5	39	18	75	6	138
PKW	460	1984	387	298	200	51	1310	256	91	240	158	133	2831	549	1657	531	1848	874	2317	529	5568
BUS	13	6	0	24	1	14	8	0	0	1	11	0	19	39	8	12	33	24	7	14	78
LFW	17	101	15	30	13	3	50	15	1	14	6	3	133	46	66	23	94	38	117	19	298
LKW	6	24	1	3	0	0	27	5	1	0	0	1	31	3	33	1	30	11	25	2	68
LZ	0	6	0	4	0	0	13	0	0	1	0	0	6	4	13	1	18	0	6	0	24
<b>KFZ</b>	<b>508</b>	<b>2193</b>	<b>408</b>	<b>359</b>	<b>216</b>	<b>68</b>	<b>1443</b>	<b>282</b>	<b>94</b>	<b>260</b>	<b>175</b>	<b>138</b>	<b>3109</b>	<b>643</b>	<b>1819</b>	<b>573</b>	<b>2062</b>	<b>965</b>	<b>2547</b>	<b>570</b>	<b>6144</b>
SV	19	36	1	31	1	14	48	5	1	2	11	1	56	46	54	14	81	35	38	16	170
PV	485	2062	392	322	203	65	1353	262	92	245	169	134	2939	590	1707	548	1920	916	2399	549	5784
GV	23	131	16	37	13	3	90	20	2	15	6	4	170	53	112	25	142	49	148	21	360
<b>FZ-ART</b>	<b>1-2</b>	<b>1-3</b>	<b>1-4</b>	<b>2-1</b>	<b>2-3</b>	<b>2-4</b>	<b>3-1</b>	<b>3-2</b>	<b>3-4</b>	<b>4-1</b>	<b>4-2</b>	<b>4-3</b>	<b>Zu. 1</b>	<b>Zu. 2</b>	<b>Zu. 3</b>	<b>Zu. 4</b>	<b>Ab. 1</b>	<b>Ab. 2</b>	<b>Ab. 3</b>	<b>Ab. 4</b>	<b>K-Sum</b>

## spezifische Spitzenstunde morgens 07:45 Uhr - 08:45 Uhr

FZ-ART	1-2	1-3	1-4	2-1	2-3	2-4	3-1	3-2	3-4	4-1	4-2	4-3	Zu. 1	Zu. 2	Zu. 3	Zu. 4	Ab. 1	Ab. 2	Ab. 3	Ab. 4	K-Sum
RAD	7	3	5	6	0	0	16	1	0	3	1	1	15	6	17	5	25	9	4	5	43
KRAD	2	1	0	0	1	1	3	1	0	0	0	0	3	2	4	0	3	3	2	1	9
PKW	150	266	86	78	17	17	473	118	17	46	28	12	502	112	608	86	597	296	295	120	1308
BUS	4	2	0	5	0	3	5	0	0	0	3	0	6	8	5	3	10	7	2	3	22
LFW	8	35	9	8	2	0	17	5	4	7	2	4	52	10	26	13	32	15	41	13	101
LKW	5	16	1	1	0	0	6	0	1	4	0	0	22	2	7	4	11	5	17	2	35
LZ	1	0	2	0	0	0	5	0	0	1	1	0	3	1	5	2	6	2	1	2	11
<b>KFZ</b>	<b>170</b>	<b>320</b>	<b>98</b>	<b>92</b>	<b>22</b>	<b>21</b>	<b>509</b>	<b>124</b>	<b>22</b>	<b>58</b>	<b>34</b>	<b>16</b>	<b>588</b>	<b>135</b>	<b>655</b>	<b>108</b>	<b>659</b>	<b>328</b>	<b>358</b>	<b>141</b>	<b>1486</b>
SV	10	18	3	6	2	3	16	0	1	5	4	0	31	11	17	9	27	14	20	7	68
PV	156	269	86	83	18	21	481	119	17	46	31	12	511	122	617	89	610	306	299	124	1339
GV	14	51	12	9	4	0	28	5	5	12	3	4	77	13	38	19	49	22	59	17	147
<b>FZ-ART</b>	<b>1-2</b>	<b>1-3</b>	<b>1-4</b>	<b>2-1</b>	<b>2-3</b>	<b>2-4</b>	<b>3-1</b>	<b>3-2</b>	<b>3-4</b>	<b>4-1</b>	<b>4-2</b>	<b>4-3</b>	<b>Zu. 1</b>	<b>Zu. 2</b>	<b>Zu. 3</b>	<b>Zu. 4</b>	<b>Ab. 1</b>	<b>Ab. 2</b>	<b>Ab. 3</b>	<b>Ab. 4</b>	<b>K-Sum</b>

## spezifische Spitzenstunde abends 16:15 Uhr - 17:15 Uhr

FZ-ART	1-2	1-3	1-4	2-1	2-3	2-4	3-1	3-2	3-4	4-1	4-2	4-3	Zu. 1	Zu. 2	Zu. 3	Zu. 4	Ab. 1	Ab. 2	Ab. 3	Ab. 4	K-Sum
RAD	7	10	18	9	1	1	29	2	2	5	6	0	35	11	33	11	43	15	11	21	90
KRAD	7	18	2	0	1	0	12	1	0	2	0	0	27	1	13	2	14	8	19	2	43
PKW	154	563	134	94	51	15	330	74	24	63	44	36	851	160	428	143	487	272	650	173	1582
BUS	1	4	0	5	0	4	2	0	0	1	1	0	5	9	2	2	8	2	4	4	18
LFW	6	28	3	5	7	0															

# Stadt Dachau

Zählstelle: K4 Augsburgur Straße / Mittermayerstraße

Zusammenfassung Stundengruppen

Zähltag: Di., 19.04.2007

Zu-/Ablauf 1: Mittermayerstr.

Zu-/Ablauf 2: Augsburgur Str. (von/nach stadteinwärts)

Zu-/Ablauf 3: Augsburgur Str. (von/nach stadtauswärts)

Zu-/Ablauf 4: Krankenhausstr.

Spezifische Spitzenstunde morgens  
07:45 Uhr - 08:45 Uhr in KFZ

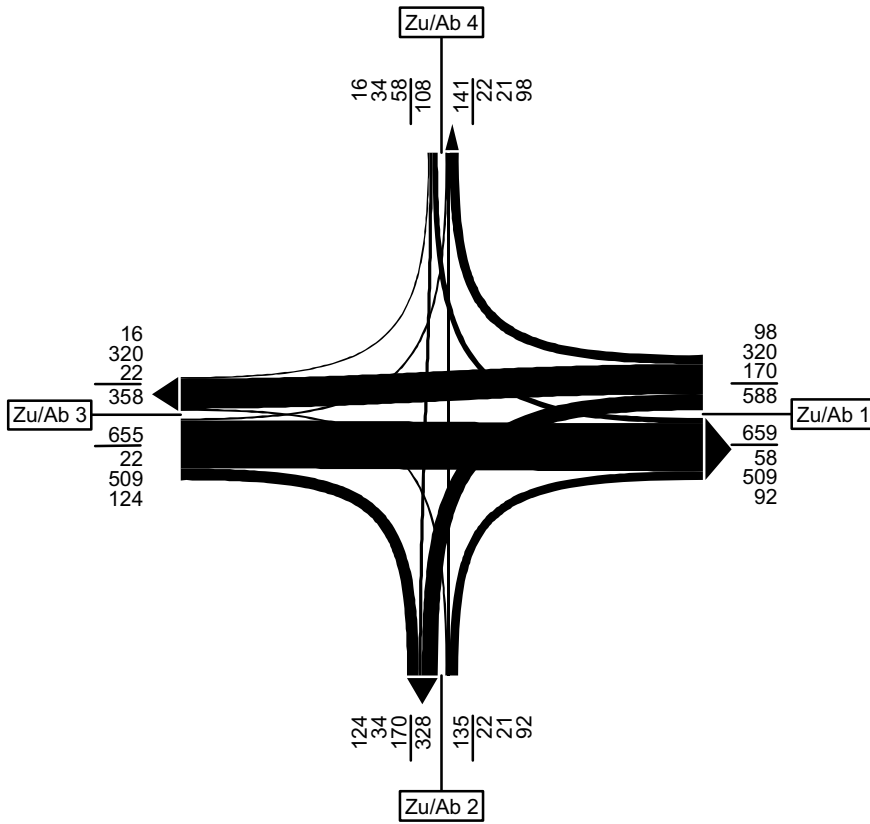

Spezifische Spitzenstunde abends  
16:15 Uhr - 17:15 Uhr in KFZ

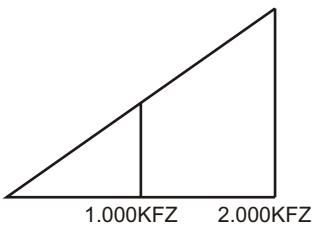
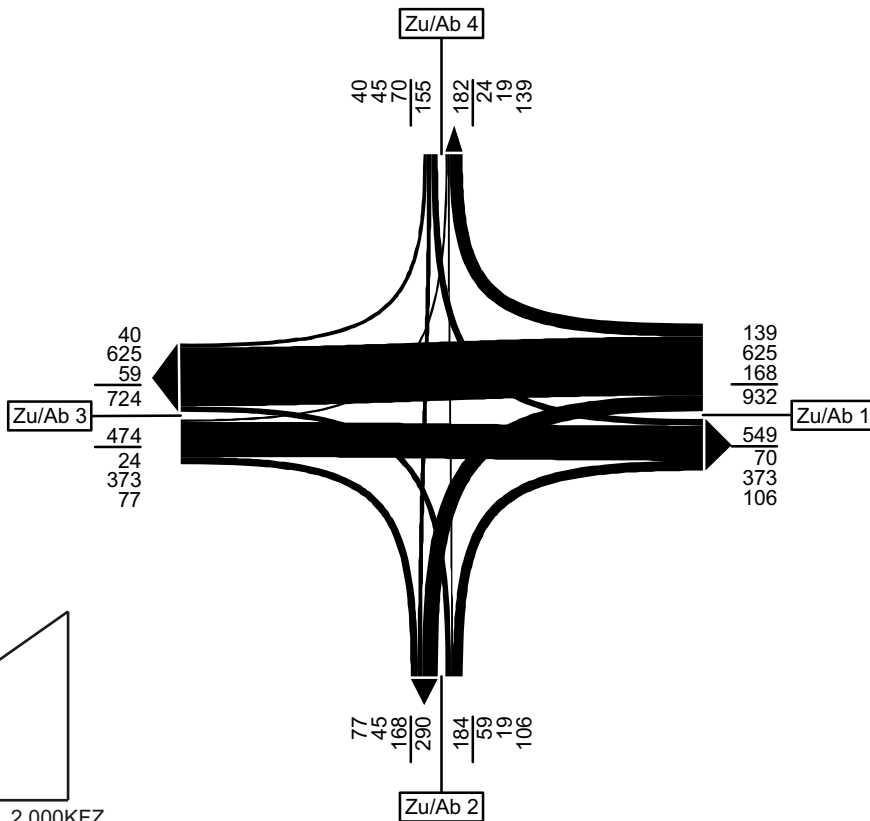

# Stadt Dachau

Zählstelle: K5 Ludwig-Thoma-Straße / Mittermayerstraße

Zu-/Ablauf 1: Mittermayerstr. (von/nach Freising)  
 Zu-/Ablauf 2: Ludwig-Thoma-Str.  
 Zu-/Ablauf 3: Mittermayerstr. (von/nach Augsburg)  
 Zu-/Ablauf 4: Steinkirchnerstr.

Zusammenfassung Stundengruppen

Zähltag: Di., 19.04.2007

Zählzeit: 06:00 Uhr - 10:00 Uhr und 15:00 Uhr - 19:00 Uhr

## Summe Zählzeit (06:00 Uhr - 10:00 Uhr und 15:00 Uhr - 19:00 Uhr)

FZ-ART	1-2	1-3	1-4	2-1	2-3	2-4	3-1	3-2	3-4	4-1	4-2	4-3	Zu. 1	Zu. 2	Zu. 3	Zu. 4	Ab. 1	Ab. 2	Ab. 3	Ab. 4	K-Sum
RAD	12	128	1	4	132	19	89	158	2	0	0	0	141	155	249	0	93	170	260	22	545
KRAD	4	42	0	1	75	5	36	48	0	0	0	0	46	81	84	0	37	52	117	5	211
PKW	92	1792	48	97	2816	172	1649	2343	30	0	0	0	1932	3085	4022	0	1746	2435	4608	250	9039
BUS	0	4	0	0	22	0	17	64	0	0	0	0	4	22	81	0	17	64	26	0	107
LFW	5	151	1	5	147	3	96	99	4	0	0	0	157	155	199	0	101	104	298	8	511
LKW	3	54	0	0	51	1	39	33	0	0	0	0	57	52	72	0	39	36	105	1	181
LZ	0	11	0	0	4	0	24	14	0	0	0	0	11	4	38	0	24	14	15	0	53
<b>KFZ</b>	<b>104</b>	<b>2054</b>	<b>49</b>	<b>103</b>	<b>3115</b>	<b>181</b>	<b>1861</b>	<b>2601</b>	<b>34</b>	<b>0</b>	<b>0</b>	<b>0</b>	<b>2207</b>	<b>3399</b>	<b>4496</b>	<b>0</b>	<b>1964</b>	<b>2705</b>	<b>5169</b>	<b>264</b>	<b>10102</b>
SV	3	69	0	0	77	1	80	111	0	0	0	0	72	78	191	0	80	114	146	1	341
PV	96	1838	48	98	2913	177	1702	2455	30	0	0	0	1982	3188	4187	0	1800	2551	4751	255	9357
GV	8	216	1	5	202	4	159	146	4	0	0	0	225	211	309	0	164	154	418	9	745
<b>FZ-ART</b>	<b>1-2</b>	<b>1-3</b>	<b>1-4</b>	<b>2-1</b>	<b>2-3</b>	<b>2-4</b>	<b>3-1</b>	<b>3-2</b>	<b>3-4</b>	<b>4-1</b>	<b>4-2</b>	<b>4-3</b>	<b>Zu. 1</b>	<b>Zu. 2</b>	<b>Zu. 3</b>	<b>Zu. 4</b>	<b>Ab. 1</b>	<b>Ab. 2</b>	<b>Ab. 3</b>	<b>Ab. 4</b>	<b>K-Sum</b>

## Summe Zählintervall 06:00 Uhr - 10:00 Uhr

FZ-ART	1-2	1-3	1-4	2-1	2-3	2-4	3-1	3-2	3-4	4-1	4-2	4-3	Zu. 1	Zu. 2	Zu. 3	Zu. 4	Ab. 1	Ab. 2	Ab. 3	Ab. 4	K-Sum
RAD	6	38	0	0	35	3	46	70	2	0	0	0	44	38	118	0	46	76	73	5	200
KRAD	1	8	0	1	6	0	12	29	0	0	0	0	9	7	41	0	13	30	14	0	57
PKW	46	742	15	30	891	42	634	1459	10	0	0	0	803	963	2103	0	664	1505	1633	67	3889
BUS	0	3	0	0	11	0	13	36	0	0	0	0	3	11	49	0	13	36	14	0	63
LFW	4	90	1	1	77	1	48	61	2	0	0	0	95	79	111	0	49	65	167	4	285
LKW	3	42	0	0	33	0	22	20	0	0	0	0	45	33	42	0	22	23	75	0	120
LZ	0	7	0	0	2	0	13	9	0	0	0	0	7	2	22	0	13	9	9	0	31
<b>KFZ</b>	<b>54</b>	<b>892</b>	<b>16</b>	<b>32</b>	<b>1020</b>	<b>43</b>	<b>742</b>	<b>1614</b>	<b>12</b>	<b>0</b>	<b>0</b>	<b>0</b>	<b>962</b>	<b>1095</b>	<b>2368</b>	<b>0</b>	<b>774</b>	<b>1668</b>	<b>1912</b>	<b>71</b>	<b>4425</b>
SV	3	52	0	0	46	0	48	65	0	0	0	0	55	46	113	0	48	68	98	0	214
PV	47	753	15	31	908	42	659	1524	10	0	0	0	815	981	2193	0	690	1571	1661	67	3989
GV	7	139	1	1	112	1	83	90	2	0	0	0	147	114	175	0	84	97	251	4	436
<b>FZ-ART</b>	<b>1-2</b>	<b>1-3</b>	<b>1-4</b>	<b>2-1</b>	<b>2-3</b>	<b>2-4</b>	<b>3-1</b>	<b>3-2</b>	<b>3-4</b>	<b>4-1</b>	<b>4-2</b>	<b>4-3</b>	<b>Zu. 1</b>	<b>Zu. 2</b>	<b>Zu. 3</b>	<b>Zu. 4</b>	<b>Ab. 1</b>	<b>Ab. 2</b>	<b>Ab. 3</b>	<b>Ab. 4</b>	<b>K-Sum</b>

## Summe Zählintervall 15:00 Uhr - 19:00 Uhr

FZ-ART	1-2	1-3	1-4	2-1	2-3	2-4	3-1	3-2	3-4	4-1	4-2	4-3	Zu. 1	Zu. 2	Zu. 3	Zu. 4	Ab. 1	Ab. 2	Ab. 3	Ab. 4	K-Sum
RAD	6	90	1	4	97	16	43	88	0	0	0	0	97	117	131	0	47	94	187	17	345
KRAD	3	34	0	0	69	5	24	19	0	0	0	0	37	74	43	0	24	22	103	5	154
PKW	46	1050	33	67	1925	130	1015	884	20	0	0	0	1129	2122	1919	0	1082	930	2975	183	5170
BUS	0	1	0	0	11	0	4	28	0	0	0	0	1	11	32	0	4	28	12	0	44
LFW	1	61	0	4	70	2	48	38	2	0	0	0	62	76	88	0	52	39	131	4	226
LKW	0	12	0	0	18	1	17	13	0	0	0	0	12	19	30	0	17	13	30	1	61
LZ	0	4	0	0	2	0	11	5	0	0	0	0	4	2	16	0	11	5	6	0	22
<b>KFZ</b>	<b>50</b>	<b>1162</b>	<b>33</b>	<b>71</b>	<b>2095</b>	<b>138</b>	<b>1119</b>	<b>987</b>	<b>22</b>	<b>0</b>	<b>0</b>	<b>0</b>	<b>1245</b>	<b>2304</b>	<b>2128</b>	<b>0</b>	<b>1190</b>	<b>1037</b>	<b>3257</b>	<b>193</b>	<b>5677</b>
SV	0	17	0	0	31	1	32	46	0	0	0	0	17	32	78	0	32	46	48	1	127
PV	49	1085	33	67	2005	135	1043	931	20	0	0	0	1167	2207	1994	0	1110	980	3090	188	5388
GV	1	77	0	4	90	3	76	56	2	0	0	0	78	97	134	0	80	57	167	5	309
<b>FZ-ART</b>	<b>1-2</b>	<b>1-3</b>	<b>1-4</b>	<b>2-1</b>	<b>2-3</b>	<b>2-4</b>	<b>3-1</b>	<b>3-2</b>	<b>3-4</b>	<b>4-1</b>	<b>4-2</b>	<b>4-3</b>	<b>Zu. 1</b>	<b>Zu. 2</b>	<b>Zu. 3</b>	<b>Zu. 4</b>	<b>Ab. 1</b>	<b>Ab. 2</b>	<b>Ab. 3</b>	<b>Ab. 4</b>	<b>K-Sum</b>

## spezifische Spitzenstunde morgens 07:45 Uhr - 08:45 Uhr

FZ-ART	1-2	1-3	1-4	2-1	2-3	2-4	3-1	3-2	3-4	4-1	4-2	4-3	Zu. 1	Zu. 2	Zu. 3	Zu. 4	Ab. 1	Ab. 2	Ab. 3	Ab. 4	K-Sum
RAD	0	13	0	0	14	0	11	19	0	0	0	0	13	14	30	0	11	19	27	0	57
KRAD	0	4	0	0	1	0	1	4	0	0	0	0	4	1	5	0	1	4	5	0	10
PKW	11	281	5	8	260	11	191	419	5	0	0	0	297	279	615	0	199	430	541	21	1191
BUS	0	1	0	0	2	0	2	8	0	0	0	0	1	2	10	0	2	8	3	0	13
LFW	0	29	0	0	23	0	13	18	1	0	0	0	29	23	32	0	13	18	52	1	84
LKW	1	8	0	0	13	0	6	5	0	0	0	0	9	13	11	0	6	6	21	0	33
LZ	0	2	0	0	0	0	2	4	0	0	0	0	2	0	6	0	2	4	2	0	8
<b>KFZ</b>	<b>12</b>	<b>325</b>	<b>5</b>	<b>8</b>	<b>299</b>	<b>11</b>	<b>215</b>	<b>458</b>	<b>6</b>	<b>0</b>	<b>0</b>	<b>0</b>	<b>342</b>	<b>318</b>	<b>679</b>	<b>0</b>	<b>223</b>	<b>470</b>	<b>624</b>	<b>22</b>	<b>1339</b>
SV	1	11	0	0	15	0	10	17	0	0	0	0	12	15	27	0	10	18	26	0	54
PV	11	286	5	8	263	11	194	431	5	0	0	0	302	282	630	0	202	442	549	21	1214
GV	1	39	0	0	36	0	21	27	1	0	0	0	40	36	49	0	21	28	75	1	125
<b>FZ-ART</b>	<b>1-2</b>	<b>1-3</b>	<b>1-4</b>	<b>2-1</b>	<b>2-3</b>	<b>2-4</b>	<b>3-1</b>	<b>3-2</b>	<b>3-4</b>	<b>4-1</b>	<b>4-2</b>	<b>4-3</b>	<b>Zu. 1</b>	<b>Zu. 2</b>	<b>Zu. 3</b>	<b>Zu. 4</b>	<b>Ab. 1</b>	<b>Ab. 2</b>	<b>Ab. 3</b>	<b>Ab. 4</b>	<b>K-Sum</b>

## spezifische Spitzenstunde abends 16:45 Uhr - 17:45 Uhr

FZ-ART	1-2	1-3	1-4	2-1	2-3	2-4	3-1	3-2	3-4	4-1	4-2	4-3	Zu. 1	Zu. 2	Zu. 3	Zu. 4	Ab. 1	Ab. 2	Ab. 3	Ab. 4	K-Sum
RAD	1	26	1	1	30	3	15	21	0	0	0	0	28	34	36	0	16	22	56	4	98
KRAD	1	13	0	0	15	0	7	5	0	0	0	0	14	15	12	0	7	6	28	0	41
PKW	12	303	12	21	532	40	264	242	5	0	0	0	327	593	511	0	285	254	835	57	1431
BUS	0	0	0	0	3	0	0	7	0	0	0	0	0	3	7	0	0	7	3	0	10
LFW	0	15	0	0	18	0	12	7	0	0	0	0	15	18	19	0	12	7	33	0	52
LKW	0	3	0	0	6	0	4	3	0												

# Stadt Dachau

Zählstelle: K5 Ludwig-Thoma-Straße / Mittermayerstraße

Zusammenfassung Stundengruppen

Zähltag: Di., 19.04.2007

Zu-/Ablauf 1: Mittermayerstr. (von/nach Freising)

Zu-/Ablauf 2: Ludwig-Thoma-Str.

Zu-/Ablauf 3: Mittermayerstr. (von/nach Augsburg)

Zu-/Ablauf 4: Steinkirchnerstr.

Spezifische Spitzenstunde morgens  
07:45 Uhr - 08:45 Uhr in KFZ

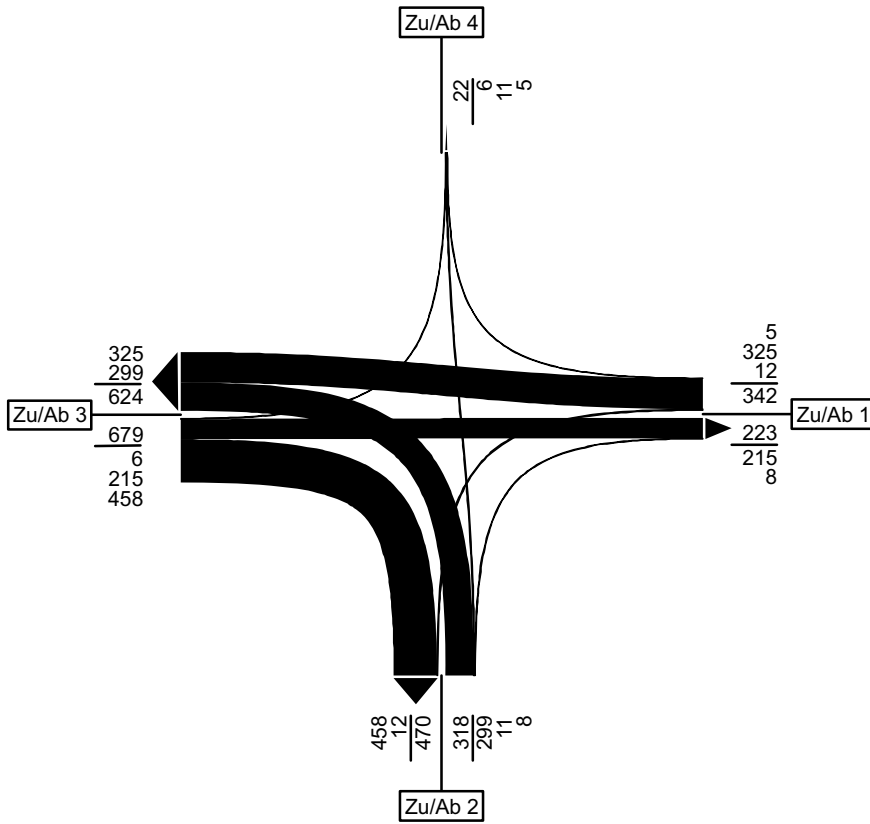

Spezifische Spitzenstunde abends  
16:45 Uhr - 17:45 Uhr in KFZ

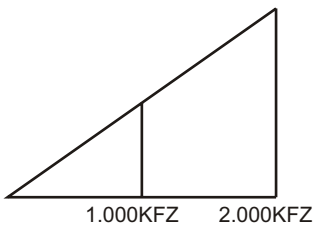
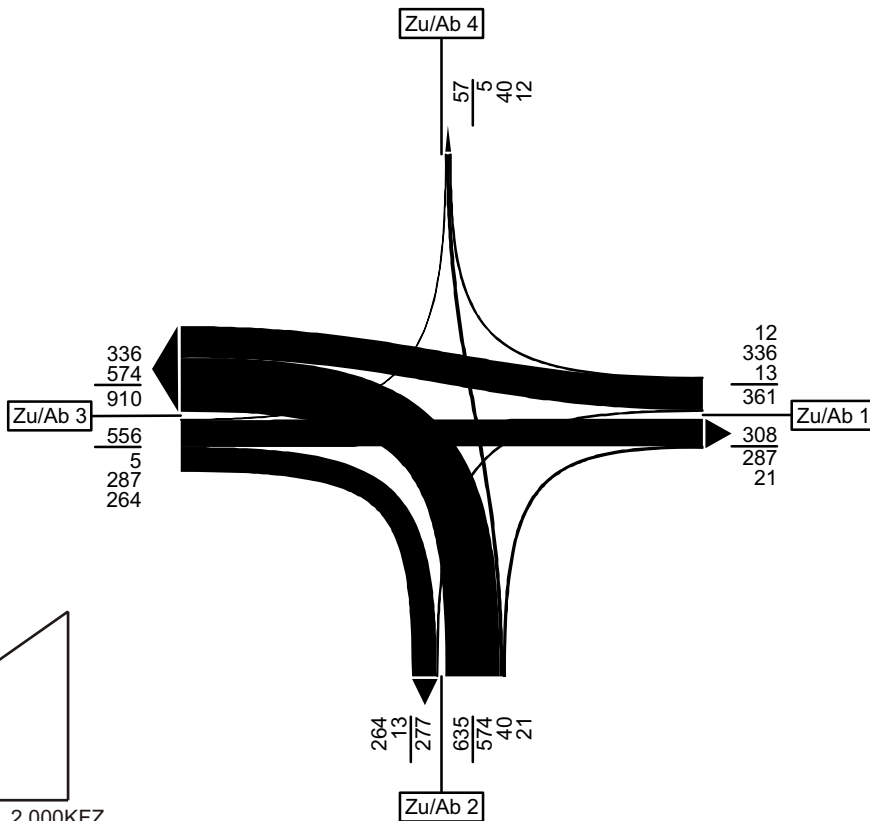

**Stadt Dachau**

Zählstelle: K6 Brucker Straße / Abzweig Einsbach

Zu-/Ablauf 1: Brucker Str. (von/nach stadteinwärts)

Zu-/Ablauf 2: Brucker Str. (von/nach stadtauswärts)

Zu-/Ablauf 3: Richtung Einsbach

Zusammenfassung Stundengruppen

Zähltag: Di., 19.04.2007

Zählzeit: 06:00 Uhr - 10:00 Uhr und 15:00 Uhr - 19:00 Uhr

**Summe Zähizeit (06:00 Uhr - 10:00 Uhr und 15:00 Uhr - 19:00 Uhr)**

FZ-ART	1-2	1-3	1-4	2-1	2-3	2-4	3-1	3-2	3-4	4-1	4-2	4-3	Zu. 1	Zu. 2	Zu. 3	Zu. 4	Ab. 1	Ab. 2	Ab. 3	Ab. 4	K-Sum
RAD	9	15	0	5	1	0	32	4	0	0	0	0	24	6	36	0	37	13	16	0	66
KRAD	51	42	0	45	1	0	41	0	0	0	0	0	93	46	41	0	86	51	43	0	180
PKW	1974	1014	0	2307	15	0	1217	8	0	0	0	0	2988	2322	1225	0	3524	1982	1029	0	6535
BUS	22	4	0	25	0	0	9	0	0	0	0	0	26	25	9	0	34	22	4	0	60
LFW	118	55	0	67	1	0	39	2	0	0	0	0	173	68	41	0	106	120	56	0	282
LKW	52	11	0	67	0	0	22	2	0	0	0	0	63	67	24	0	89	54	11	0	154
LZ	92	7	0	67	1	0	12	0	0	0	0	0	99	68	12	0	79	92	8	0	179
<b>KFZ</b>	<b>2309</b>	<b>1133</b>	<b>0</b>	<b>2578</b>	<b>18</b>	<b>0</b>	<b>1340</b>	<b>12</b>	<b>0</b>	<b>0</b>	<b>0</b>	<b>0</b>	<b>3442</b>	<b>2596</b>	<b>1352</b>	<b>0</b>	<b>3918</b>	<b>2321</b>	<b>1151</b>	<b>0</b>	<b>7390</b>
SV	166	22	0	159	1	0	43	2	0	0	0	0	188	160	45	0	202	168	23	0	393
PV	2047	1060	0	2377	16	0	1267	8	0	0	0	0	3107	2393	1275	0	3644	2055	1076	0	6775
GV	262	73	0	201	2	0	73	4	0	0	0	0	335	203	77	0	274	266	75	0	615
<b>FZ-ART</b>	<b>1-2</b>	<b>1-3</b>	<b>1-4</b>	<b>2-1</b>	<b>2-3</b>	<b>2-4</b>	<b>3-1</b>	<b>3-2</b>	<b>3-4</b>	<b>4-1</b>	<b>4-2</b>	<b>4-3</b>	<b>Zu. 1</b>	<b>Zu. 2</b>	<b>Zu. 3</b>	<b>Zu. 4</b>	<b>Ab. 1</b>	<b>Ab. 2</b>	<b>Ab. 3</b>	<b>Ab. 4</b>	<b>K-Sum</b>

**Summe Zählintervall 06:00 Uhr - 10:00 Uhr**

FZ-ART	1-2	1-3	1-4	2-1	2-3	2-4	3-1	3-2	3-4	4-1	4-2	4-3	Zu. 1	Zu. 2	Zu. 3	Zu. 4	Ab. 1	Ab. 2	Ab. 3	Ab. 4	K-Sum
RAD	4	2	0	2	0	0	9	0	0	0	0	0	6	2	9	0	11	4	2	0	17
KRAD	8	6	0	19	1	0	20	0	0	0	0	0	14	20	20	0	39	8	7	0	54
PKW	804	233	0	1126	3	0	747	1	0	0	0	0	1037	1129	748	0	1873	805	236	0	2914
BUS	11	4	0	17	0	0	7	0	0	0	0	0	15	17	7	0	24	11	4	0	39
LFW	66	23	0	45	1	0	21	0	0	0	0	0	89	46	21	0	66	66	24	0	156
LKW	31	5	0	42	0	0	17	2	0	0	0	0	36	42	19	0	59	33	5	0	97
LZ	58	1	0	39	1	0	2	0	0	0	0	0	59	40	2	0	41	58	2	0	101
<b>KFZ</b>	<b>978</b>	<b>272</b>	<b>0</b>	<b>1288</b>	<b>6</b>	<b>0</b>	<b>814</b>	<b>3</b>	<b>0</b>	<b>0</b>	<b>0</b>	<b>0</b>	<b>1250</b>	<b>1294</b>	<b>817</b>	<b>0</b>	<b>2102</b>	<b>981</b>	<b>278</b>	<b>0</b>	<b>3361</b>
SV	100	10	0	98	1	0	26	2	0	0	0	0	110	99	28	0	124	102	11	0	237
PV	823	243	0	1162	4	0	774	1	0	0	0	0	1066	1166	775	0	1936	824	247	0	3007
GV	155	29	0	126	2	0	40	2	0	0	0	0	184	128	42	0	166	157	31	0	354
<b>FZ-ART</b>	<b>1-2</b>	<b>1-3</b>	<b>1-4</b>	<b>2-1</b>	<b>2-3</b>	<b>2-4</b>	<b>3-1</b>	<b>3-2</b>	<b>3-4</b>	<b>4-1</b>	<b>4-2</b>	<b>4-3</b>	<b>Zu. 1</b>	<b>Zu. 2</b>	<b>Zu. 3</b>	<b>Zu. 4</b>	<b>Ab. 1</b>	<b>Ab. 2</b>	<b>Ab. 3</b>	<b>Ab. 4</b>	<b>K-Sum</b>

**Summe Zählintervall 15:00 Uhr - 19:00 Uhr**

FZ-ART	1-2	1-3	1-4	2-1	2-3	2-4	3-1	3-2	3-4	4-1	4-2	4-3	Zu. 1	Zu. 2	Zu. 3	Zu. 4	Ab. 1	Ab. 2	Ab. 3	Ab. 4	K-Sum
RAD	5	13	0	3	1	0	23	4	0	0	0	0	18	4	27	0	26	9	14	0	49
KRAD	43	36	0	26	0	0	21	0	0	0	0	0	79	26	21	0	47	43	36	0	126
PKW	1170	781	0	1181	12	0	470	7	0	0	0	0	1951	1193	477	0	1651	1177	793	0	3621
BUS	11	0	0	8	0	0	2	0	0	0	0	0	11	8	2	0	10	11	0	0	21
LFW	52	32	0	22	0	0	18	2	0	0	0	0	84	22	20	0	40	54	32	0	126
LKW	21	6	0	25	0	0	5	0	0	0	0	0	27	25	5	0	30	21	6	0	57
LZ	34	6	0	28	0	0	10	0	0	0	0	0	40	28	10	0	38	34	6	0	78
<b>KFZ</b>	<b>1331</b>	<b>861</b>	<b>0</b>	<b>1290</b>	<b>12</b>	<b>0</b>	<b>526</b>	<b>9</b>	<b>0</b>	<b>0</b>	<b>0</b>	<b>0</b>	<b>2192</b>	<b>1302</b>	<b>535</b>	<b>0</b>	<b>1816</b>	<b>1340</b>	<b>873</b>	<b>0</b>	<b>4029</b>
SV	66	12	0	61	0	0	17	0	0	0	0	0	78	61	17	0	78	66	12	0	156
PV	1224	817	0	1215	12	0	493	7	0	0	0	0	2041	1227	500	0	1708	1231	829	0	3768
GV	107	44	0	75	0	0	33	2	0	0	0	0	151	75	35	0	108	109	44	0	261
<b>FZ-ART</b>	<b>1-2</b>	<b>1-3</b>	<b>1-4</b>	<b>2-1</b>	<b>2-3</b>	<b>2-4</b>	<b>3-1</b>	<b>3-2</b>	<b>3-4</b>	<b>4-1</b>	<b>4-2</b>	<b>4-3</b>	<b>Zu. 1</b>	<b>Zu. 2</b>	<b>Zu. 3</b>	<b>Zu. 4</b>	<b>Ab. 1</b>	<b>Ab. 2</b>	<b>Ab. 3</b>	<b>Ab. 4</b>	<b>K-Sum</b>

**spezifische Spitzenstunde morgens 07:15 Uhr - 08:15 Uhr**

FZ-ART	1-2	1-3	1-4	2-1	2-3	2-4	3-1	3-2	3-4	4-1	4-2	4-3	Zu. 1	Zu. 2	Zu. 3	Zu. 4	Ab. 1	Ab. 2	Ab. 3	Ab. 4	K-Sum
RAD	2	0	0	1	0	0	2	0	0	0	0	0	2	1	2	0	3	2	0	0	5
KRAD	1	1	0	8	0	0	10	0	0	0	0	0	2	8	10	0	18	1	1	0	20
PKW	236	56	0	406	1	0	274	1	0	0	0	0	292	407	275	0	680	237	57	0	974
BUS	5	2	0	7	0	0	6	0	0	0	0	0	7	7	6	0	13	5	2	0	20
LFW	18	8	0	10	1	0	6	0	0	0	0	0	26	11	6	0	16	18	9	0	43
LKW	8	2	0	13	0	0	6	1	0	0	0	0	10	13	7	0	19	9	2	0	30
LZ	11	0	0	12	0	0	1	0	0	0	0	0	11	12	1	0	13	11	0	0	24
<b>KFZ</b>	<b>279</b>	<b>69</b>	<b>0</b>	<b>456</b>	<b>2</b>	<b>0</b>	<b>303</b>	<b>2</b>	<b>0</b>	<b>0</b>	<b>0</b>	<b>0</b>	<b>348</b>	<b>458</b>	<b>305</b>	<b>0</b>	<b>759</b>	<b>281</b>	<b>71</b>	<b>0</b>	<b>1111</b>
SV	24	4	0	32	0	0	13	1	0	0	0	0	28	32	14	0	45	25	4	0	74
PV	242	59	0	421	1	0	290	1	0	0	0	0	301	422	291	0	711	243	60	0	1014
GV	37	10	0	35	1	0	13	1	0	0	0	0	47	36	14	0	48	38	11	0	97
<b>FZ-ART</b>	<b>1-2</b>	<b>1-3</b>	<b>1-4</b>	<b>2-1</b>	<b>2-3</b>	<b>2-4</b>	<b>3-1</b>	<b>3-2</b>	<b>3-4</b>	<b>4-1</b>	<b>4-2</b>	<b>4-3</b>	<b>Zu. 1</b>	<b>Zu. 2</b>	<b>Zu. 3</b>	<b>Zu. 4</b>	<b>Ab. 1</b>	<b>Ab. 2</b>	<b>Ab. 3</b>	<b>Ab. 4</b>	<b>K-Sum</b>

**spezifische Spitzenstunde abends 16:30 Uhr - 17:30 Uhr**

FZ-ART	1-2	1-3	1-4	2-1	2-3	2-4	3-1	3-2	3-4	4-1	4-2	4-3	Zu. 1	Zu. 2	Zu. 3	Zu. 4	Ab. 1	Ab. 2	Ab. 3	Ab. 4	K-Sum
RAD	1	3	0	1	0	0	7	1	0	0	0	0	4	1	8	0	8	2	3	0	13
KRAD	12	10	0	8	0	0	9	0	0	0	0	0	22	8	9	0	17	12	10	0	39
PKW	334	221	0	365	3	0	121	3	0	0	0	0	555	368	124	0	486	337	224	0	1047
BUS	3	0	0	3	0	0	0	0	0	0	0	0	3	3	0	0	3	3	0	0	6
LFW	13	6	0	8	0	0	4	0	0	0	0	0	19	8	4	0	12	13	6	0	31
LKW	7	0	0	7	0	0	0	0	0	0	0	0	7	7	0	0	7	7	0	0	14
LZ	8	2																			

# Stadt Dachau

Zählstelle: K6 Brucker Straße / Abzweig Einsbach

Zusammenfassung Stundengruppen

Zähltag: Di., 19.04.2007

Zu-/Ablauf 1: Brucker Str. (von/nach stadteinwärts)

Zu-/Ablauf 2: Brucker Str. (von/nach stadtauswärts)

Zu-/Ablauf 3: Richtung Einsbach

Spezifische Spitzenstunde morgens  
07:15 Uhr - 08:15 Uhr in KFZ

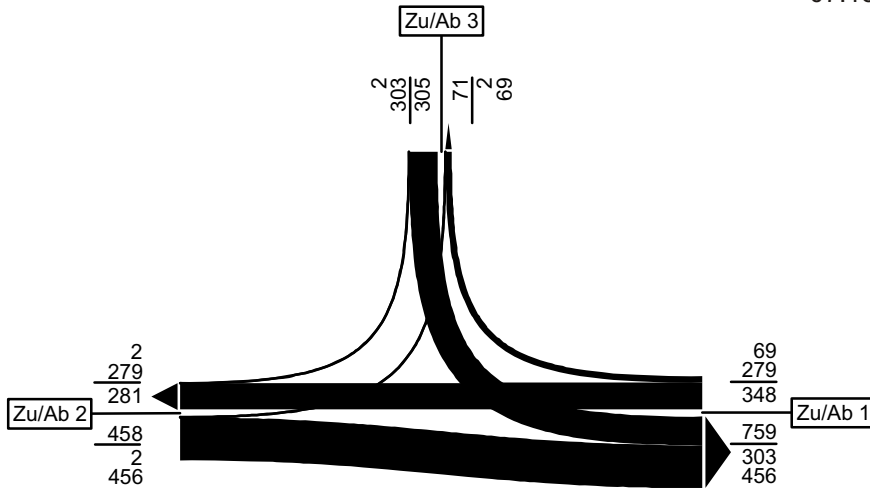

Spezifische Spitzenstunde abends  
16:30 Uhr - 17:30 Uhr in KFZ

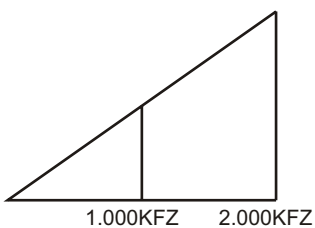
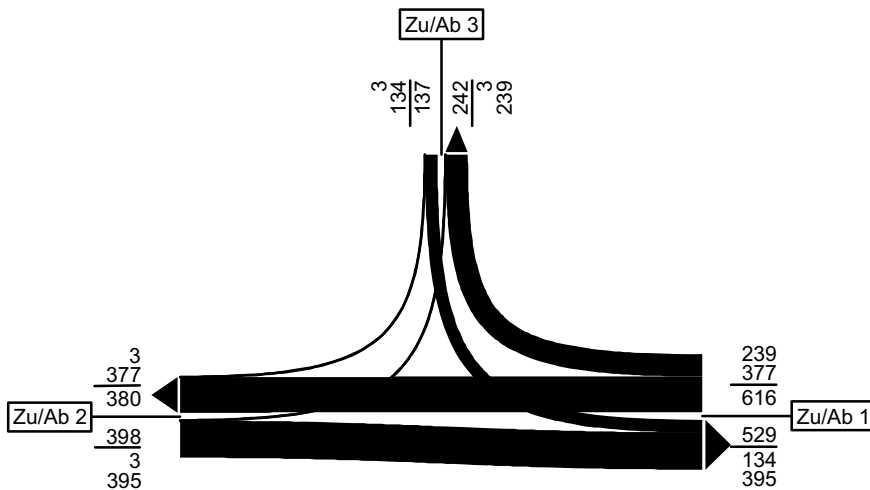

# Stadt Dachau

Zählstelle: K8 Ludwig-Thoma-Straße / Ostenstraße

Zu-/Ablauf 1: Ostenstr.

Zu-/Ablauf 2: Ludwig-Thoma-Str. (von/nach Thomawiese)

Zu-/Ablauf 3: Ludwig-Thoma-Str. (von/nach Freising)

Zusammenfassung Stundengruppen

Zähltag: Di., 19.04.2007

Zählzeit: 06:00 Uhr - 10:00 Uhr und 15:00 Uhr - 19:00 Uhr

## Summe Zählzeit (06:00 Uhr - 10:00 Uhr und 15:00 Uhr - 19:00 Uhr)

FZ-ART	1-2	1-3	1-4	2-1	2-3	2-4	3-1	3-2	3-4	4-1	4-2	4-3	Zu. 1	Zu. 2	Zu. 3	Zu. 4	Ab. 1	Ab. 2	Ab. 3	Ab. 4	K-Sum
RAD	27	13	0	47	302	0	16	316	0	0	0	0	40	349	332	0	63	343	315	0	721
KRAD	11	3	0	11	157	0	10	123	0	0	0	0	14	168	133	0	21	134	160	0	315
PKW	404	200	0	401	5232	0	290	3697	0	0	0	0	604	5633	3987	0	691	4101	5432	0	10224
BUS	0	1	0	0	96	0	0	86	0	0	0	0	1	96	86	0	0	86	97	0	183
LFW	20	6	0	16	348	0	10	222	0	0	0	0	26	364	232	0	26	242	354	0	622
LKW	7	2	0	5	66	0	9	71	0	0	0	0	9	71	80	0	14	78	68	0	160
LZ	3	16	0	5	32	0	14	62	0	0	0	0	19	37	76	0	19	65	48	0	132
<b>KFZ</b>	<b>445</b>	<b>228</b>	<b>0</b>	<b>438</b>	<b>5931</b>	<b>0</b>	<b>333</b>	<b>4261</b>	<b>0</b>	<b>0</b>	<b>0</b>	<b>0</b>	<b>673</b>	<b>6369</b>	<b>4594</b>	<b>0</b>	<b>771</b>	<b>4706</b>	<b>6159</b>	<b>0</b>	<b>11636</b>
SV	10	19	0	10	194	0	23	219	0	0	0	0	29	204	242	0	33	229	213	0	475
PV	415	204	0	412	5485	0	300	3906	0	0	0	0	619	5897	4206	0	712	4321	5689	0	10722
GV	30	24	0	26	446	0	33	355	0	0	0	0	54	472	388	0	59	385	470	0	914
<b>FZ-ART</b>	<b>1-2</b>	<b>1-3</b>	<b>1-4</b>	<b>2-1</b>	<b>2-3</b>	<b>2-4</b>	<b>3-1</b>	<b>3-2</b>	<b>3-4</b>	<b>4-1</b>	<b>4-2</b>	<b>4-3</b>	<b>Zu. 1</b>	<b>Zu. 2</b>	<b>Zu. 3</b>	<b>Zu. 4</b>	<b>Ab. 1</b>	<b>Ab. 2</b>	<b>Ab. 3</b>	<b>Ab. 4</b>	<b>K-Sum</b>

## Summe Zählintervall 06:00 Uhr - 10:00 Uhr

FZ-ART	1-2	1-3	1-4	2-1	2-3	2-4	3-1	3-2	3-4	4-1	4-2	4-3	Zu. 1	Zu. 2	Zu. 3	Zu. 4	Ab. 1	Ab. 2	Ab. 3	Ab. 4	K-Sum
RAD	10	6	0	12	109	0	4	157	0	0	0	0	16	121	161	0	16	167	115	0	298
KRAD	5	0	0	3	39	0	2	55	0	0	0	0	5	42	57	0	5	60	39	0	104
PKW	174	74	0	152	1679	0	156	2167	0	0	0	0	248	1831	2323	0	308	2341	1753	0	4402
BUS	0	1	0	0	48	0	0	50	0	0	0	0	1	48	50	0	0	50	49	0	99
LFW	10	6	0	7	172	0	8	136	0	0	0	0	16	179	144	0	15	146	178	0	339
LKW	6	2	0	4	40	0	7	51	0	0	0	0	8	44	58	0	11	57	42	0	110
LZ	3	8	0	3	16	0	7	37	0	0	0	0	11	19	44	0	10	40	24	0	74
<b>KFZ</b>	<b>198</b>	<b>91</b>	<b>0</b>	<b>169</b>	<b>1994</b>	<b>0</b>	<b>180</b>	<b>2496</b>	<b>0</b>	<b>0</b>	<b>0</b>	<b>0</b>	<b>289</b>	<b>2163</b>	<b>2676</b>	<b>0</b>	<b>349</b>	<b>2694</b>	<b>2085</b>	<b>0</b>	<b>5128</b>
SV	9	11	0	7	104	0	14	138	0	0	0	0	20	111	152	0	21	147	115	0	283
PV	179	75	0	155	1766	0	158	2272	0	0	0	0	254	1921	2430	0	313	2451	1841	0	4605
GV	19	16	0	14	228	0	22	224	0	0	0	0	35	242	246	0	36	243	244	0	523
<b>FZ-ART</b>	<b>1-2</b>	<b>1-3</b>	<b>1-4</b>	<b>2-1</b>	<b>2-3</b>	<b>2-4</b>	<b>3-1</b>	<b>3-2</b>	<b>3-4</b>	<b>4-1</b>	<b>4-2</b>	<b>4-3</b>	<b>Zu. 1</b>	<b>Zu. 2</b>	<b>Zu. 3</b>	<b>Zu. 4</b>	<b>Ab. 1</b>	<b>Ab. 2</b>	<b>Ab. 3</b>	<b>Ab. 4</b>	<b>K-Sum</b>

## Summe Zählintervall 15:00 Uhr - 19:00 Uhr

FZ-ART	1-2	1-3	1-4	2-1	2-3	2-4	3-1	3-2	3-4	4-1	4-2	4-3	Zu. 1	Zu. 2	Zu. 3	Zu. 4	Ab. 1	Ab. 2	Ab. 3	Ab. 4	K-Sum
RAD	17	7	0	35	193	0	12	159	0	0	0	0	24	228	171	0	47	176	200	0	423
KRAD	6	3	0	8	118	0	8	68	0	0	0	0	9	126	76	0	16	74	121	0	211
PKW	230	126	0	249	3553	0	134	1530	0	0	0	0	356	3802	1664	0	383	1760	3679	0	5822
BUS	0	0	0	0	48	0	0	36	0	0	0	0	0	48	36	0	0	36	48	0	84
LFW	10	0	0	9	176	0	2	86	0	0	0	0	10	185	88	0	11	96	176	0	283
LKW	1	0	0	1	26	0	2	20	0	0	0	0	1	27	22	0	3	21	26	0	50
LZ	0	8	0	2	16	0	7	25	0	0	0	0	8	18	32	0	9	25	24	0	58
<b>KFZ</b>	<b>247</b>	<b>137</b>	<b>0</b>	<b>269</b>	<b>3937</b>	<b>0</b>	<b>153</b>	<b>1765</b>	<b>0</b>	<b>0</b>	<b>0</b>	<b>0</b>	<b>384</b>	<b>4206</b>	<b>1918</b>	<b>0</b>	<b>422</b>	<b>2012</b>	<b>4074</b>	<b>0</b>	<b>6508</b>
SV	1	8	0	3	90	0	9	81	0	0	0	0	9	93	90	0	12	82	98	0	192
PV	236	129	0	257	3719	0	142	1634	0	0	0	0	365	3976	1776	0	399	1870	3848	0	6117
GV	11	8	0	12	218	0	11	131	0	0	0	0	19	230	142	0	23	142	226	0	391
<b>FZ-ART</b>	<b>1-2</b>	<b>1-3</b>	<b>1-4</b>	<b>2-1</b>	<b>2-3</b>	<b>2-4</b>	<b>3-1</b>	<b>3-2</b>	<b>3-4</b>	<b>4-1</b>	<b>4-2</b>	<b>4-3</b>	<b>Zu. 1</b>	<b>Zu. 2</b>	<b>Zu. 3</b>	<b>Zu. 4</b>	<b>Ab. 1</b>	<b>Ab. 2</b>	<b>Ab. 3</b>	<b>Ab. 4</b>	<b>K-Sum</b>

## spezifische Spitzenstunde morgens 07:15 Uhr - 08:15 Uhr

FZ-ART	1-2	1-3	1-4	2-1	2-3	2-4	3-1	3-2	3-4	4-1	4-2	4-3	Zu. 1	Zu. 2	Zu. 3	Zu. 4	Ab. 1	Ab. 2	Ab. 3	Ab. 4	K-Sum
RAD	2	3	0	5	43	0	3	71	0	0	0	0	5	48	74	0	8	73	46	0	127
KRAD	3	0	0	0	10	0	2	20	0	0	0	0	3	10	22	0	2	23	10	0	35
PKW	78	28	0	43	466	0	59	694	0	0	0	0	106	509	753	0	102	772	494	0	1368
BUS	0	0	0	0	17	0	0	18	0	0	0	0	0	17	18	0	0	18	17	0	35
LFW	1	3	0	2	52	0	3	35	0	0	0	0	4	54	38	0	5	36	55	0	96
LKW	3	0	0	1	6	0	0	17	0	0	0	0	3	7	17	0	1	20	6	0	27
LZ	2	3	0	1	8	0	2	8	0	0	0	0	5	9	10	0	3	10	11	0	24
<b>KFZ</b>	<b>87</b>	<b>34</b>	<b>0</b>	<b>47</b>	<b>559</b>	<b>0</b>	<b>66</b>	<b>792</b>	<b>0</b>	<b>0</b>	<b>0</b>	<b>0</b>	<b>121</b>	<b>606</b>	<b>858</b>	<b>0</b>	<b>113</b>	<b>879</b>	<b>593</b>	<b>0</b>	<b>1585</b>
SV	5	3	0	2	31	0	2	43	0	0	0	0	8	33	45	0	4	48	34	0	86
PV	81	28	0	43	493	0	61	732	0	0	0	0	109	536	793	0	104	813	521	0	1438
GV	6	6	0	4	66	0	5	60	0	0	0	0	12	70	65	0	9	66	72	0	147
<b>FZ-ART</b>	<b>1-2</b>	<b>1-3</b>	<b>1-4</b>	<b>2-1</b>	<b>2-3</b>	<b>2-4</b>	<b>3-1</b>	<b>3-2</b>	<b>3-4</b>	<b>4-1</b>	<b>4-2</b>	<b>4-3</b>	<b>Zu. 1</b>	<b>Zu. 2</b>	<b>Zu. 3</b>	<b>Zu. 4</b>	<b>Ab. 1</b>	<b>Ab. 2</b>	<b>Ab. 3</b>	<b>Ab. 4</b>	<b>K-Sum</b>

## spezifische Spitzenstunde abends 16:15 Uhr - 17:15 Uhr

FZ-ART	1-2	1-3	1-4	2-1	2-3	2-4	3-1	3-2	3-4	4-1	4-2	4-3	Zu. 1	Zu. 2	Zu. 3	Zu. 4	Ab. 1	Ab. 2	Ab. 3	Ab. 4	K-Sum
RAD	5	1	0	6	44	0	4	41	0	0	0	0	6	50	45	0	10	46	45	0	101
KRAD	2	2	0	4	30	0	2	15	0	0	0	0	4	34	17	0	6	17	32	0	55
PKW	72	36	0	86	935	0	43	391	0	0	0	0	108	1021	434	0	129	463	971	0	1563
BUS	0	0	0	0	15	0	0	11	0	0	0	0	0	15	11	0	0	11	15	0	26
LFW	1	0	0	4	46	0	0	22	0	0	0	0	1	50	22	0	4	23	46	0	73
LKW	0	0	0	0	8	0	1	6	0												



# Stadt Dachau

Zählstelle: K8 Ludwig-Thoma-Straße / Ostenstraße

Zusammenfassung Stundengruppen

Zähltag: Di., 19.04.2007

Zu-/Ablauf 1: Ostenstr.

Zu-/Ablauf 2: Ludwig-Thoma-Str. (von/nach Thomawiese)

Zu-/Ablauf 3: Ludwig-Thoma-Str. (von/nach Freising)

Spezifische Spitzenstunde morgens  
07:15 Uhr - 08:15 Uhr in KFZ

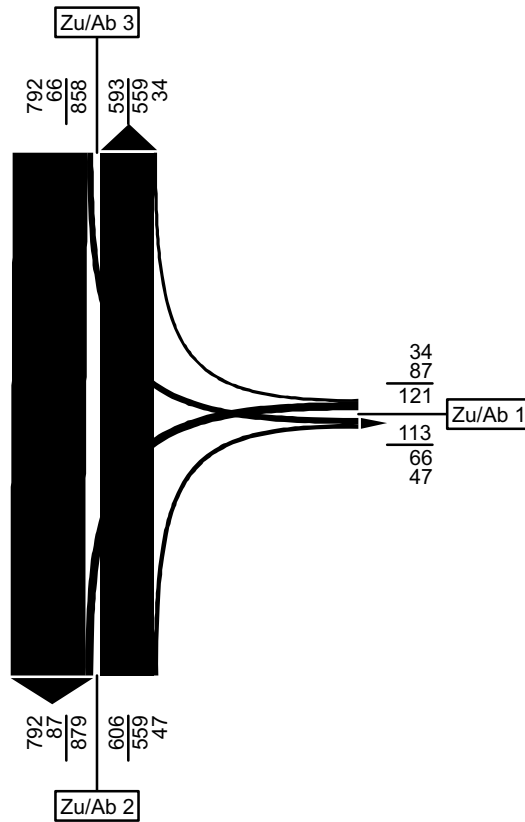

Spezifische Spitzenstunde abends  
16:15 Uhr - 17:15 Uhr in KFZ

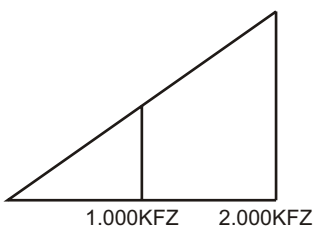
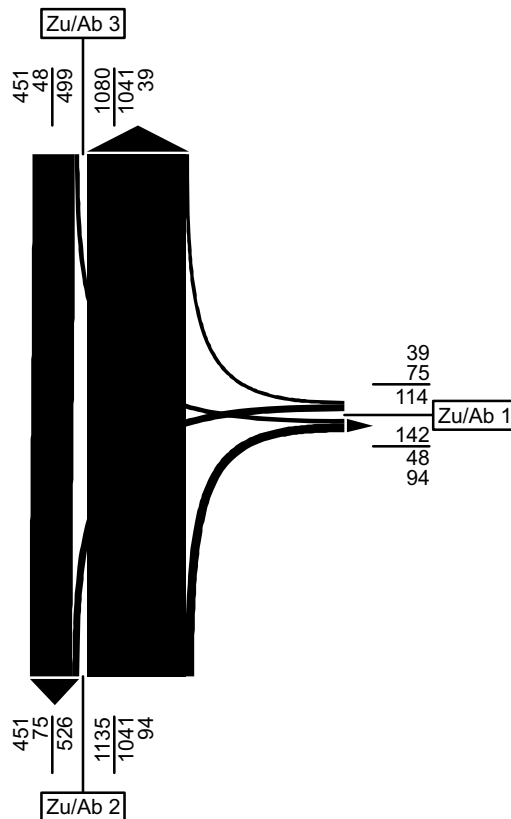

**Stadt Dachau**

Zählstelle: K9 Ludwig-Thoma-Straße / Martin-Huber-Straße

Zu-/Ablauf 1: Ludwig-Thoma-Str. (von/nach Freising)

Zu-/Ablauf 2: Martin-Huber-Str.

Zu-/Ablauf 3: Ludwig-Thoma-Str. (von/nach Thomawiese)

Zusammenfassung Stundengruppen

Zähltag: Di., 19.04.2007

Zählzeit: 06:00 Uhr - 10:00 Uhr und 15:00 Uhr - 19:00 Uhr

**Summe Zählzeit (06:00 Uhr - 10:00 Uhr und 15:00 Uhr - 19:00 Uhr)**

FZ-ART	1-2	1-3	1-4	2-1	2-3	2-4	3-1	3-2	3-4	4-1	4-2	4-3	Zu. 1	Zu. 2	Zu. 3	Zu. 4	Ab. 1	Ab. 2	Ab. 3	Ab. 4	K-Sum
RAD	225	118	0	156	0	0	193	52	0	0	0	0	343	156	245	0	349	277	118	0	744
KRAD	50	84	0	50	0	0	118	3	0	0	0	0	134	50	121	0	168	53	84	0	305
PKW	1910	2191	0	2137	0	0	3496	78	0	0	0	0	4101	2137	3574	0	5633	1988	2191	0	9812
BUS	18	68	0	22	0	0	74	1	0	0	0	0	86	22	75	0	96	19	68	0	183
LFW	46	196	0	85	0	0	279	3	0	0	0	0	242	85	282	0	364	49	196	0	609
LKW	9	69	0	25	0	0	46	2	0	0	0	0	78	25	48	0	71	11	69	0	151
LZ	11	54	0	3	0	0	34	1	0	0	0	0	65	3	35	0	37	12	54	0	103
<b>KFZ</b>	<b>2044</b>	<b>2662</b>	<b>0</b>	<b>2322</b>	<b>0</b>	<b>0</b>	<b>4047</b>	<b>88</b>	<b>0</b>	<b>0</b>	<b>0</b>	<b>0</b>	<b>4706</b>	<b>2322</b>	<b>4135</b>	<b>0</b>	<b>6369</b>	<b>2132</b>	<b>2662</b>	<b>0</b>	<b>11163</b>
SV	38	191	0	50	0	0	154	4	0	0	0	0	229	50	158	0	204	42	191	0	437
PV	1978	2343	0	2209	0	0	3688	82	0	0	0	0	4321	2209	3770	0	5897	2060	2343	0	10300
GV	66	319	0	113	0	0	359	6	0	0	0	0	385	113	365	0	472	72	319	0	863
<b>FZ-ART</b>	<b>1-2</b>	<b>1-3</b>	<b>1-4</b>	<b>2-1</b>	<b>2-3</b>	<b>2-4</b>	<b>3-1</b>	<b>3-2</b>	<b>3-4</b>	<b>4-1</b>	<b>4-2</b>	<b>4-3</b>	<b>Zu. 1</b>	<b>Zu. 2</b>	<b>Zu. 3</b>	<b>Zu. 4</b>	<b>Ab. 1</b>	<b>Ab. 2</b>	<b>Ab. 3</b>	<b>Ab. 4</b>	<b>K-Sum</b>

**Summe Zählintervall 06:00 Uhr - 10:00 Uhr**

FZ-ART	1-2	1-3	1-4	2-1	2-3	2-4	3-1	3-2	3-4	4-1	4-2	4-3	Zu. 1	Zu. 2	Zu. 3	Zu. 4	Ab. 1	Ab. 2	Ab. 3	Ab. 4	K-Sum
RAD	121	46	0	43	0	0	78	11	0	0	0	0	167	43	89	0	121	132	46	0	299
KRAD	24	36	0	6	0	0	36	3	0	0	0	0	60	6	39	0	42	27	36	0	105
PKW	1009	1332	0	691	0	0	1140	50	0	0	0	0	2341	691	1190	0	1831	1059	1332	0	4222
BUS	14	36	0	11	0	0	37	1	0	0	0	0	50	11	38	0	48	15	36	0	99
LFW	20	126	0	35	0	0	144	3	0	0	0	0	146	35	147	0	179	23	126	0	328
LKW	8	49	0	17	0	0	27	1	0	0	0	0	57	17	28	0	44	9	49	0	102
LZ	5	35	0	3	0	0	16	1	0	0	0	0	40	3	17	0	19	6	35	0	60
<b>KFZ</b>	<b>1080</b>	<b>1614</b>	<b>0</b>	<b>763</b>	<b>0</b>	<b>0</b>	<b>1400</b>	<b>59</b>	<b>0</b>	<b>0</b>	<b>0</b>	<b>0</b>	<b>2694</b>	<b>763</b>	<b>1459</b>	<b>0</b>	<b>2163</b>	<b>1139</b>	<b>1614</b>	<b>0</b>	<b>4916</b>
SV	27	120	0	31	0	0	80	3	0	0	0	0	147	31	83	0	111	30	120	0	261
PV	1047	1404	0	708	0	0	1213	54	0	0	0	0	2451	708	1267	0	1921	1101	1404	0	4426
GV	33	210	0	55	0	0	187	5	0	0	0	0	243	55	192	0	242	38	210	0	490
<b>FZ-ART</b>	<b>1-2</b>	<b>1-3</b>	<b>1-4</b>	<b>2-1</b>	<b>2-3</b>	<b>2-4</b>	<b>3-1</b>	<b>3-2</b>	<b>3-4</b>	<b>4-1</b>	<b>4-2</b>	<b>4-3</b>	<b>Zu. 1</b>	<b>Zu. 2</b>	<b>Zu. 3</b>	<b>Zu. 4</b>	<b>Ab. 1</b>	<b>Ab. 2</b>	<b>Ab. 3</b>	<b>Ab. 4</b>	<b>K-Sum</b>

**Summe Zählintervall 15:00 Uhr - 19:00 Uhr**

FZ-ART	1-2	1-3	1-4	2-1	2-3	2-4	3-1	3-2	3-4	4-1	4-2	4-3	Zu. 1	Zu. 2	Zu. 3	Zu. 4	Ab. 1	Ab. 2	Ab. 3	Ab. 4	K-Sum
RAD	104	72	0	113	0	0	115	41	0	0	0	0	176	113	156	0	228	145	72	0	445
KRAD	26	48	0	44	0	0	82	0	0	0	0	0	74	44	82	0	126	26	48	0	200
PKW	901	859	0	1446	0	0	2356	28	0	0	0	0	1760	1446	2384	0	3802	929	859	0	5590
BUS	4	32	0	11	0	0	37	0	0	0	0	0	36	11	37	0	48	4	32	0	84
LFW	26	70	0	50	0	0	135	0	0	0	0	0	96	50	135	0	185	26	70	0	281
LKW	1	20	0	8	0	0	19	1	0	0	0	0	21	8	20	0	27	2	20	0	49
LZ	6	19	0	0	0	0	18	0	0	0	0	0	25	0	18	0	18	6	19	0	43
<b>KFZ</b>	<b>964</b>	<b>1048</b>	<b>0</b>	<b>1559</b>	<b>0</b>	<b>0</b>	<b>2647</b>	<b>29</b>	<b>0</b>	<b>0</b>	<b>0</b>	<b>0</b>	<b>2012</b>	<b>1559</b>	<b>2676</b>	<b>0</b>	<b>4206</b>	<b>993</b>	<b>1048</b>	<b>0</b>	<b>6247</b>
SV	11	71	0	19	0	0	74	1	0	0	0	0	82	19	75	0	93	12	71	0	176
PV	931	939	0	1501	0	0	2475	28	0	0	0	0	1870	1501	2503	0	3976	959	939	0	5874
GV	33	109	0	58	0	0	172	1	0	0	0	0	142	58	173	0	230	34	109	0	373
<b>FZ-ART</b>	<b>1-2</b>	<b>1-3</b>	<b>1-4</b>	<b>2-1</b>	<b>2-3</b>	<b>2-4</b>	<b>3-1</b>	<b>3-2</b>	<b>3-4</b>	<b>4-1</b>	<b>4-2</b>	<b>4-3</b>	<b>Zu. 1</b>	<b>Zu. 2</b>	<b>Zu. 3</b>	<b>Zu. 4</b>	<b>Ab. 1</b>	<b>Ab. 2</b>	<b>Ab. 3</b>	<b>Ab. 4</b>	<b>K-Sum</b>

**spezifische Spitzenstunde morgens 07:15 Uhr - 08:15 Uhr**

FZ-ART	1-2	1-3	1-4	2-1	2-3	2-4	3-1	3-2	3-4	4-1	4-2	4-3	Zu. 1	Zu. 2	Zu. 3	Zu. 4	Ab. 1	Ab. 2	Ab. 3	Ab. 4	K-Sum
RAD	67	6	0	11	0	0	37	3	0	0	0	0	73	11	40	0	48	70	6	0	124
KRAD	10	13	0	2	0	0	8	1	0	0	0	0	23	2	9	0	10	11	13	0	34
PKW	395	377	0	180	0	0	329	25	0	0	0	0	772	180	354	0	509	420	377	0	1306
BUS	4	14	0	6	0	0	11	1	0	0	0	0	18	6	12	0	17	5	14	0	36
LFW	6	30	0	7	0	0	47	2	0	0	0	0	36	7	49	0	54	8	30	0	92
LKW	5	15	0	2	0	0	5	1	0	0	0	0	20	2	6	0	7	6	15	0	28
LZ	1	9	0	2	0	0	7	1	0	0	0	0	10	2	8	0	9	2	9	0	20
<b>KFZ</b>	<b>421</b>	<b>458</b>	<b>0</b>	<b>199</b>	<b>0</b>	<b>0</b>	<b>407</b>	<b>31</b>	<b>0</b>	<b>0</b>	<b>0</b>	<b>0</b>	<b>879</b>	<b>199</b>	<b>438</b>	<b>0</b>	<b>606</b>	<b>452</b>	<b>458</b>	<b>0</b>	<b>1516</b>
SV	10	38	0	10	0	0	23	3	0	0	0	0	48	10	26	0	33	13	38	0	84
PV	409	404	0	188	0	0	348	27	0	0	0	0	813	188	375	0	536	436	404	0	1376
GV	12	54	0	11	0	0	59	4	0	0	0	0	66	11	63	0	70	16	54	0	140
<b>FZ-ART</b>	<b>1-2</b>	<b>1-3</b>	<b>1-4</b>	<b>2-1</b>	<b>2-3</b>	<b>2-4</b>	<b>3-1</b>	<b>3-2</b>	<b>3-4</b>	<b>4-1</b>	<b>4-2</b>	<b>4-3</b>	<b>Zu. 1</b>	<b>Zu. 2</b>	<b>Zu. 3</b>	<b>Zu. 4</b>	<b>Ab. 1</b>	<b>Ab. 2</b>	<b>Ab. 3</b>	<b>Ab. 4</b>	<b>K-Sum</b>

**spezifische Spitzenstunde abends 16:15 Uhr - 17:15 Uhr**

FZ-ART	1-2	1-3	1-4	2-1	2-3	2-4	3-1	3-2	3-4	4-1	4-2	4-3	Zu. 1	Zu. 2	Zu. 3	Zu. 4	Ab. 1	Ab. 2	Ab. 3	Ab. 4	K-Sum
RAD	25	21	0	33	0	0	17	14	0	0	0	0	46	33	31	0	50	39	21	0	110
KRAD	5	12	0	11	0	0	23	0	0	0	0	0	17	11	23	0	34	5	12	0	51
PKW	249	214	0	411	0	0	610	9	0	0	0	0	463	411	619	0	1021	258	214	0	1493
BUS	1	10	0	6	0	0	9	0	0	0	0	0	11	6	9	0	15	1	10	0	26
LFW	5	18	0	11	0	0	39	0	0	0	0	0	23	11	39	0	50	5	18	0	73
LKW	1	5	0																		

# Stadt Dachau

Zählstelle: K9 Ludwig-Thoma-Straße / Martin-Huber-Straße

Zusammenfassung Stundengruppen

Zähltag: Di., 19.04.2007

Zu-/Ablauf 1: Ludwig-Thoma-Str. (von/nach Freising)

Zu-/Ablauf 2: Martin-Huber-Str.

Zu-/Ablauf 3: Ludwig-Thoma-Str. (von/nach Thomawiese)

Spezifische Spitzenstunde morgens  
07:15 Uhr - 08:15 Uhr in KFZ

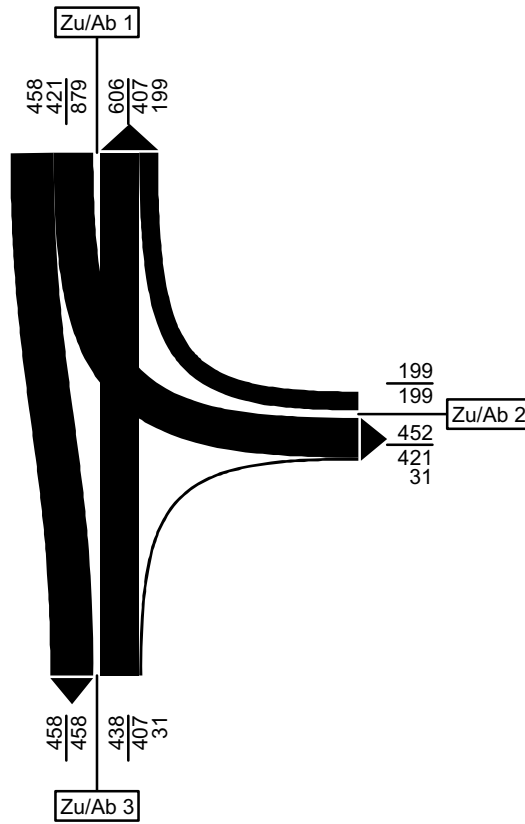

Spezifische Spitzenstunde abends  
16:15 Uhr - 17:15 Uhr in KFZ

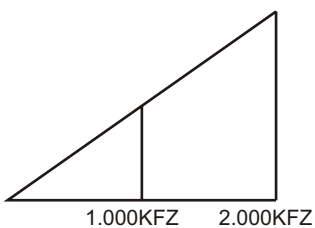
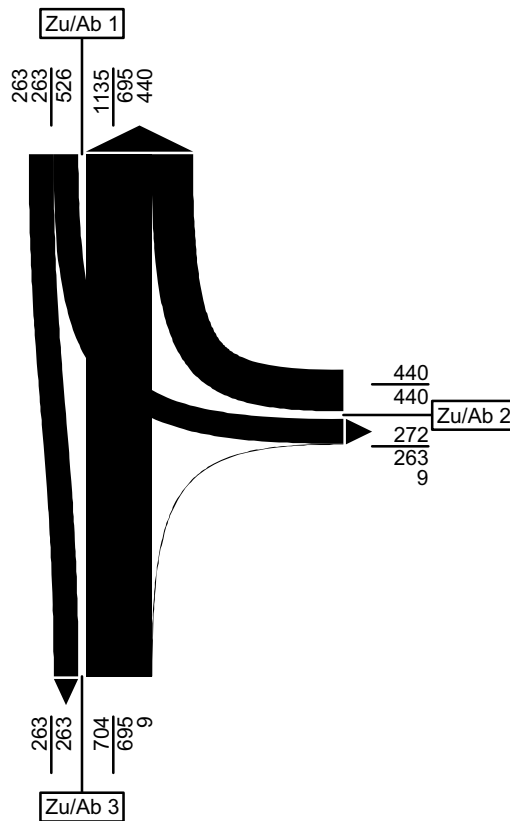



# Stadt Dachau

Zählstelle: K10 Ludwig-Thoma-Straße / Karlsberg

Zusammenfassung Stundengruppen

Zähltag: Di., 24.04.2007

Zu-/Ablauf 1: Ludwig-Thoma-Str.

Zu-/Ablauf 2: Münchener Str.

Zu-/Ablauf 3: Rotkreuzplatz

Zu-/Ablauf 4: Karlsberg

Spezifische Spitzenstunde morgens  
07:30 Uhr - 08:30 Uhr in KFZ

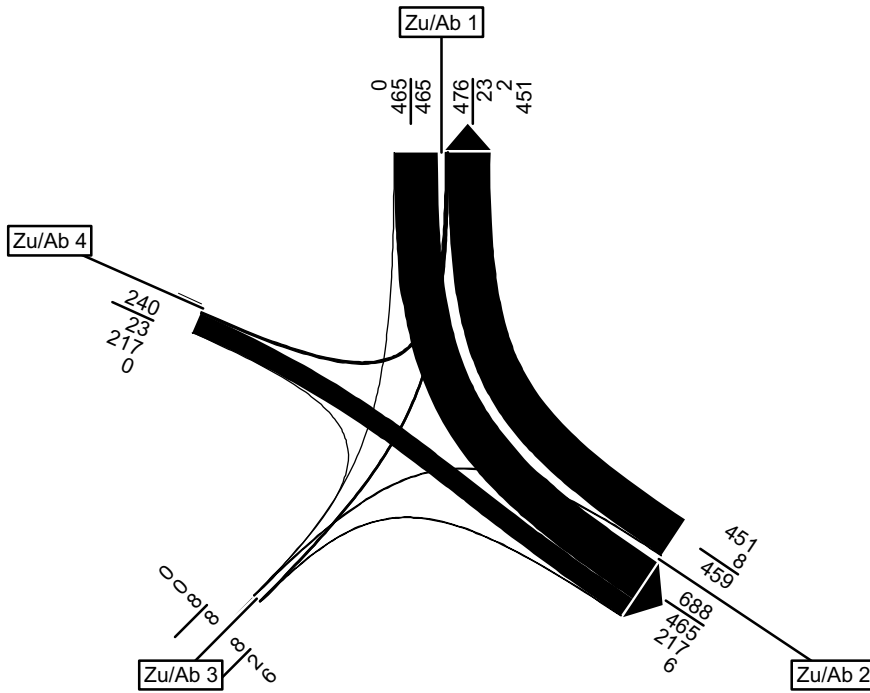

Spezifische Spitzenstunde abends  
16:30 Uhr - 17:30 Uhr in KFZ

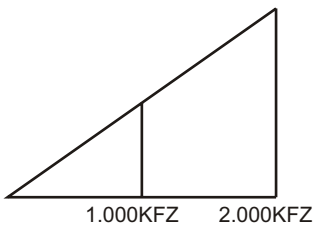
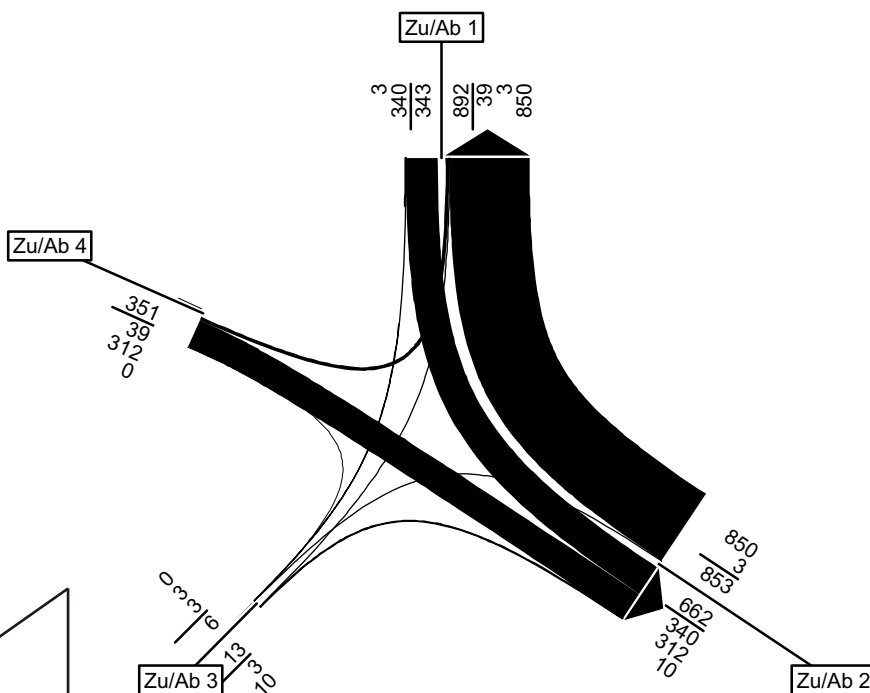

# Stadt Dachau

Zählstelle: K11 Augsburg Straße / Karlsberg

Zu-/Ablauf 1: Konrad-Adenauer Str.

Zu-/Ablauf 2: Karlsberg

Zu-/Ablauf 3: Augsburg Str.

Zusammenfassung Stundengruppen

Zähltag: Di., 24.04.2007

Zählzeit: 06:00 Uhr - 10:00 Uhr und 15:00 Uhr - 19:00 Uhr

## Summe Zählzeit (06:00 Uhr - 10:00 Uhr und 15:00 Uhr - 19:00 Uhr)

FZ-ART	1-2	1-3	1-4	2-1	2-3	2-4	3-1	3-2	3-4	4-1	4-2	4-3	Zu. 1	Zu. 2	Zu. 3	Zu. 4	Ab. 1	Ab. 2	Ab. 3	Ab. 4	K-Sum
RAD	15	5	0	0	0	0	12	33	0	0	0	0	20	0	45	0	12	48	5	0	65
KRAD	11	22	0	0	0	0	14	30	0	0	0	0	33	0	44	0	14	41	22	0	77
PKW	391	1007	0	0	0	0	595	1322	0	0	0	0	1398	0	1917	0	595	1713	1007	0	3315
BUS	0	66	0	0	0	0	24	0	0	0	0	0	66	0	24	0	24	0	66	0	90
LFW	13	28	0	0	0	0	18	67	0	0	0	0	41	0	85	0	18	80	28	0	126
LKW	0	7	0	0	0	0	5	13	0	0	0	0	7	0	18	0	5	13	7	0	25
LZ	0	0	0	0	0	0	1	1	0	0	0	0	0	0	2	0	1	1	0	0	2
<b>KFZ</b>	<b>415</b>	<b>1130</b>	<b>0</b>	<b>0</b>	<b>0</b>	<b>0</b>	<b>657</b>	<b>1433</b>	<b>0</b>	<b>0</b>	<b>0</b>	<b>0</b>	<b>1545</b>	<b>0</b>	<b>2090</b>	<b>0</b>	<b>657</b>	<b>1848</b>	<b>1130</b>	<b>0</b>	<b>3635</b>
SV	0	73	0	0	0	0	30	14	0	0	0	0	73	0	44	0	30	14	73	0	117
PV	402	1095	0	0	0	0	633	1352	0	0	0	0	1497	0	1985	0	633	1754	1095	0	3482
GV	13	35	0	0	0	0	24	81	0	0	0	0	48	0	105	0	24	94	35	0	153
<b>FZ-ART</b>	<b>1-2</b>	<b>1-3</b>	<b>1-4</b>	<b>2-1</b>	<b>2-3</b>	<b>2-4</b>	<b>3-1</b>	<b>3-2</b>	<b>3-4</b>	<b>4-1</b>	<b>4-2</b>	<b>4-3</b>	<b>Zu. 1</b>	<b>Zu. 2</b>	<b>Zu. 3</b>	<b>Zu. 4</b>	<b>Ab. 1</b>	<b>Ab. 2</b>	<b>Ab. 3</b>	<b>Ab. 4</b>	<b>K-Sum</b>

## Summe Zählintervall 06:00 Uhr - 10:00 Uhr

FZ-ART	1-2	1-3	1-4	2-1	2-3	2-4	3-1	3-2	3-4	4-1	4-2	4-3	Zu. 1	Zu. 2	Zu. 3	Zu. 4	Ab. 1	Ab. 2	Ab. 3	Ab. 4	K-Sum
RAD	5	2	0	0	0	0	3	8	0	0	0	0	7	0	11	0	3	13	2	0	18
KRAD	1	7	0	0	0	0	4	7	0	0	0	0	8	0	11	0	4	8	7	0	19
PKW	184	386	0	0	0	0	303	581	0	0	0	0	570	0	884	0	303	765	386	0	1454
BUS	0	30	0	0	0	0	12	0	0	0	0	0	30	0	12	0	12	0	30	0	42
LFW	8	10	0	0	0	0	11	43	0	0	0	0	18	0	54	0	11	51	10	0	72
LKW	0	4	0	0	0	0	5	11	0	0	0	0	4	0	16	0	5	11	4	0	20
LZ	0	0	0	0	0	0	0	0	0	0	0	0	0	0	0	0	0	0	0	0	0
<b>KFZ</b>	<b>193</b>	<b>437</b>	<b>0</b>	<b>0</b>	<b>0</b>	<b>0</b>	<b>335</b>	<b>642</b>	<b>0</b>	<b>0</b>	<b>0</b>	<b>0</b>	<b>630</b>	<b>0</b>	<b>977</b>	<b>0</b>	<b>335</b>	<b>835</b>	<b>437</b>	<b>0</b>	<b>1607</b>
SV	0	34	0	0	0	0	17	11	0	0	0	0	34	0	28	0	17	11	34	0	62
PV	185	423	0	0	0	0	319	588	0	0	0	0	608	0	907	0	319	773	423	0	1515
GV	8	14	0	0	0	0	16	54	0	0	0	0	22	0	70	0	16	62	14	0	92
<b>FZ-ART</b>	<b>1-2</b>	<b>1-3</b>	<b>1-4</b>	<b>2-1</b>	<b>2-3</b>	<b>2-4</b>	<b>3-1</b>	<b>3-2</b>	<b>3-4</b>	<b>4-1</b>	<b>4-2</b>	<b>4-3</b>	<b>Zu. 1</b>	<b>Zu. 2</b>	<b>Zu. 3</b>	<b>Zu. 4</b>	<b>Ab. 1</b>	<b>Ab. 2</b>	<b>Ab. 3</b>	<b>Ab. 4</b>	<b>K-Sum</b>

## Summe Zählintervall 15:00 Uhr - 19:00 Uhr

FZ-ART	1-2	1-3	1-4	2-1	2-3	2-4	3-1	3-2	3-4	4-1	4-2	4-3	Zu. 1	Zu. 2	Zu. 3	Zu. 4	Ab. 1	Ab. 2	Ab. 3	Ab. 4	K-Sum
RAD	10	3	0	0	0	0	9	25	0	0	0	0	13	0	34	0	9	35	3	0	47
KRAD	10	15	0	0	0	0	10	23	0	0	0	0	25	0	33	0	10	33	15	0	58
PKW	207	621	0	0	0	0	292	741	0	0	0	0	828	0	1033	0	292	948	621	0	1861
BUS	0	36	0	0	0	0	12	0	0	0	0	0	36	0	12	0	12	0	36	0	48
LFW	5	18	0	0	0	0	7	24	0	0	0	0	23	0	31	0	7	29	18	0	54
LKW	0	3	0	0	0	0	0	2	0	0	0	0	3	0	2	0	0	2	3	0	5
LZ	0	0	0	0	0	0	1	1	0	0	0	0	0	0	2	0	1	1	0	0	2
<b>KFZ</b>	<b>222</b>	<b>693</b>	<b>0</b>	<b>0</b>	<b>0</b>	<b>0</b>	<b>322</b>	<b>791</b>	<b>0</b>	<b>0</b>	<b>0</b>	<b>0</b>	<b>915</b>	<b>0</b>	<b>1113</b>	<b>0</b>	<b>322</b>	<b>1013</b>	<b>693</b>	<b>0</b>	<b>2028</b>
SV	0	39	0	0	0	0	13	3	0	0	0	0	39	0	16	0	13	3	39	0	55
PV	217	672	0	0	0	0	314	764	0	0	0	0	889	0	1078	0	314	981	672	0	1967
GV	5	21	0	0	0	0	8	27	0	0	0	0	26	0	35	0	8	32	21	0	61
<b>FZ-ART</b>	<b>1-2</b>	<b>1-3</b>	<b>1-4</b>	<b>2-1</b>	<b>2-3</b>	<b>2-4</b>	<b>3-1</b>	<b>3-2</b>	<b>3-4</b>	<b>4-1</b>	<b>4-2</b>	<b>4-3</b>	<b>Zu. 1</b>	<b>Zu. 2</b>	<b>Zu. 3</b>	<b>Zu. 4</b>	<b>Ab. 1</b>	<b>Ab. 2</b>	<b>Ab. 3</b>	<b>Ab. 4</b>	<b>K-Sum</b>

## spezifische Spitzenstunde morgens 09:00 Uhr - 10:00 Uhr

FZ-ART	1-2	1-3	1-4	2-1	2-3	2-4	3-1	3-2	3-4	4-1	4-2	4-3	Zu. 1	Zu. 2	Zu. 3	Zu. 4	Ab. 1	Ab. 2	Ab. 3	Ab. 4	K-Sum
RAD	3	0	0	0	0	0	2	1	0	0	0	0	3	0	3	0	2	4	0	0	6
KRAD	1	4	0	0	0	0	2	2	0	0	0	0	5	0	4	0	2	3	4	0	9
PKW	56	167	0	0	0	0	97	164	0	0	0	0	223	0	261	0	97	220	167	0	484
BUS	0	9	0	0	0	0	3	0	0	0	0	0	9	0	3	0	3	0	9	0	12
LFW	2	2	0	0	0	0	2	10	0	0	0	0	4	0	12	0	2	12	2	0	16
LKW	0	3	0	0	0	0	3	3	0	0	0	0	3	0	6	0	3	3	3	0	9
LZ	0	0	0	0	0	0	0	0	0	0	0	0	0	0	0	0	0	0	0	0	0
<b>KFZ</b>	<b>59</b>	<b>185</b>	<b>0</b>	<b>0</b>	<b>0</b>	<b>0</b>	<b>107</b>	<b>179</b>	<b>0</b>	<b>0</b>	<b>0</b>	<b>0</b>	<b>244</b>	<b>0</b>	<b>286</b>	<b>0</b>	<b>107</b>	<b>238</b>	<b>185</b>	<b>0</b>	<b>530</b>
SV	0	12	0	0	0	0	6	3	0	0	0	0	12	0	9	0	6	3	12	0	21
PV	57	180	0	0	0	0	102	166	0	0	0	0	237	0	268	0	102	223	180	0	505
GV	2	5	0	0	0	0	5	13	0	0	0	0	7	0	18	0	5	15	5	0	25
<b>FZ-ART</b>	<b>1-2</b>	<b>1-3</b>	<b>1-4</b>	<b>2-1</b>	<b>2-3</b>	<b>2-4</b>	<b>3-1</b>	<b>3-2</b>	<b>3-4</b>	<b>4-1</b>	<b>4-2</b>	<b>4-3</b>	<b>Zu. 1</b>	<b>Zu. 2</b>	<b>Zu. 3</b>	<b>Zu. 4</b>	<b>Ab. 1</b>	<b>Ab. 2</b>	<b>Ab. 3</b>	<b>Ab. 4</b>	<b>K-Sum</b>

## spezifische Spitzenstunde abends 16:15 Uhr - 17:15 Uhr

FZ-ART	1-2	1-3	1-4	2-1	2-3	2-4	3-1	3-2	3-4	4-1	4-2	4-3	Zu. 1	Zu. 2	Zu. 3	Zu. 4	Ab. 1	Ab. 2	Ab. 3	Ab. 4	K-Sum
RAD	3	0	0	0	0	0	3	7	0	0	0	0	3	0	10	0	3	10	0	0	13
KRAD	4	2	0	0	0	0	4	8	0	0	0	0	6	0	12	0	4	12	2	0	18
PKW	52	189	0	0	0	0	79	256	0	0	0	0	241	0	335	0	79	308	189	0	576
BUS	0	9	0	0	0	0	3	0	0	0	0	0	9	0	3	0	3	0	9	0	12
LFW	2	3	0	0	0	0	1	6	0	0	0	0	5	0	7	0	1	8	3	0	12
LKW	0	1	0	0	0	0	0	0	0	0	0	0	1	0	0	0	0	0	1	0	1
LZ	0	0	0	0	0	0	0	1	0	0	0	0	0	0	1	0	0	1	0	0	1
<b>KFZ</b>	<b>58</b>	<b>204</b>	<b>0</b>	<b>0</b>	<b>0</b>	<b>0</b>	<b>87</b>	<b>271</b>	<b>0</b>	<											

# Stadt Dachau

Zählstelle: K11 Augsburg Straße / Karlsberg

Zusammenfassung Stundengruppen

Zähltag: Di., 24.04.2007

Zu-/Ablauf 1: Konrad-Adenauer Str.

Zu-/Ablauf 2: Karlsberg

Zu-/Ablauf 3: Augsburg Str.

Spezifische Spitzenstunde morgens  
09:00 Uhr - 10:00 Uhr in KFZ

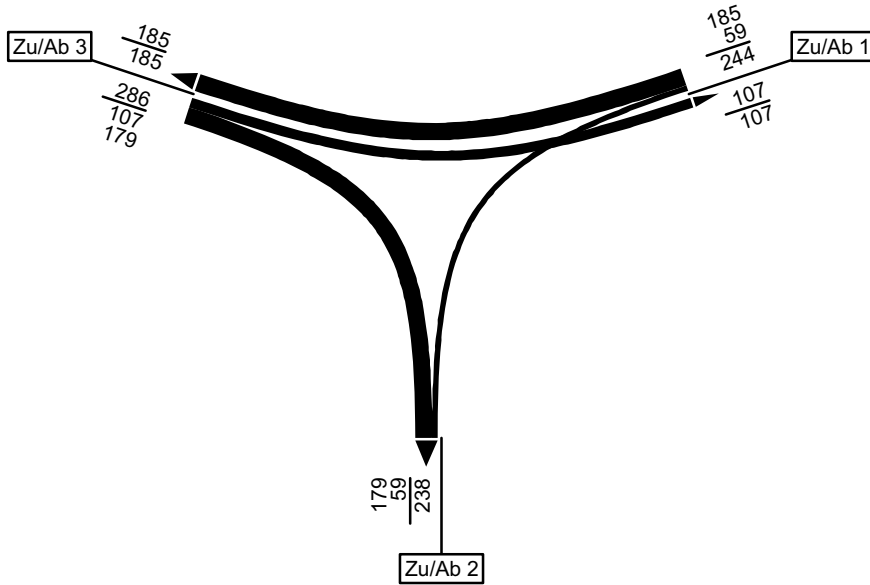

Spezifische Spitzenstunde abends  
16:15 Uhr - 17:15 Uhr in KFZ

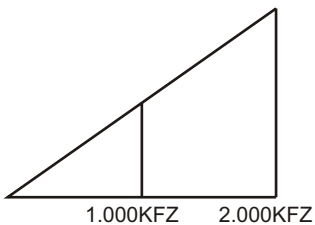
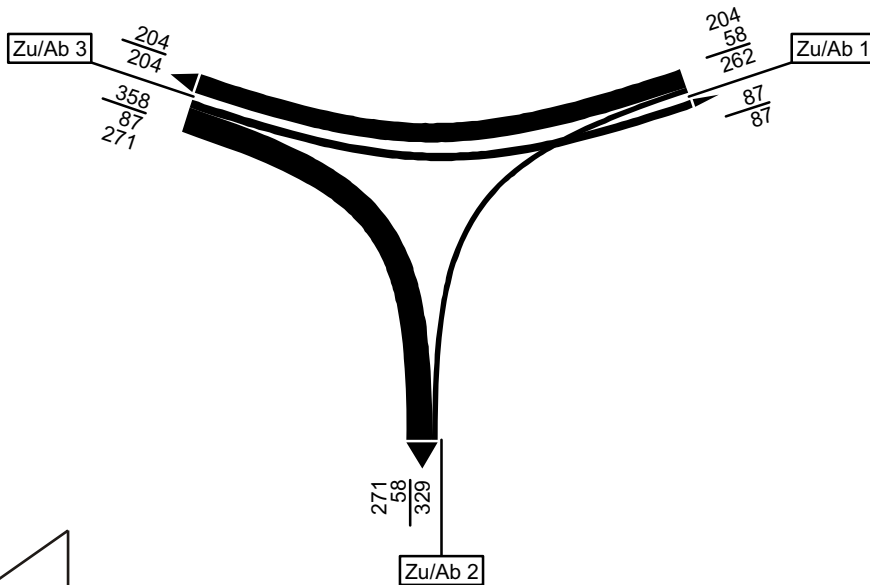

# Stadt Dachau

Zählstelle: K12 Gröbenrieder Straße / Himmelreichweg

Zu-/Ablauf 1: Uhdestr.

Zu-/Ablauf 2: Gröbenrieder Str. (von/nach Stadteinwärts)

Zu-/Ablauf 3: Gröbenrieder Str. (von/nach Stadtauswärts)

Zu-/Ablauf 4: Himmelreichweg

Zusammenfassung Stundengruppen

Zähltag: Di., 24.04.2007

Zählzeit: 06:00 Uhr - 10:00 Uhr und 15:00 Uhr - 19:00 Uhr

## Summe Zählzeit (06:00 Uhr - 10:00 Uhr und 15:00 Uhr - 19:00 Uhr)

FZ-ART	1-2	1-3	1-4	2-1	2-3	2-4	3-1	3-2	3-4	4-1	4-2	4-3	Zu. 1	Zu. 2	Zu. 3	Zu. 4	Ab. 1	Ab. 2	Ab. 3	Ab. 4	K-Sum
RAD	2	61	28	1	7	15	10	32	14	46	78	1	91	23	56	125	57	112	69	57	295
KRAD	0	15	7	1	18	0	0	18	0	19	8	5	22	19	18	32	20	26	38	7	91
PKW	12	646	32	30	672	182	617	592	172	31	361	486	690	884	1381	876	678	965	1804	386	3833
BUS	0	3	2	0	4	1	1	2	2	0	1	1	5	5	5	2	1	3	8	5	17
LFW	0	25	6	2	30	8	67	37	10	5	18	25	31	40	114	48	74	55	80	24	233
LKW	0	9	4	0	14	1	13	11	6	2	4	6	13	15	30	12	15	15	29	11	70
LZ	0	2	1	0	9	0	6	4	3	2	2	1	3	9	13	5	8	6	12	4	30
<b>KFZ</b>	<b>12</b>	<b>700</b>	<b>52</b>	<b>33</b>	<b>747</b>	<b>192</b>	<b>704</b>	<b>664</b>	<b>193</b>	<b>59</b>	<b>394</b>	<b>524</b>	<b>764</b>	<b>972</b>	<b>1561</b>	<b>977</b>	<b>796</b>	<b>1070</b>	<b>1971</b>	<b>437</b>	<b>4274</b>
SV	0	14	7	0	27	2	20	17	11	4	7	8	21	29	48	19	24	24	49	20	117
PV	12	664	41	31	694	183	618	612	174	50	370	492	717	908	1404	912	699	994	1850	398	3941
GV	0	36	11	2	53	9	86	52	19	9	24	32	47	64	157	65	97	76	121	39	333
<b>FZ-ART</b>	<b>1-2</b>	<b>1-3</b>	<b>1-4</b>	<b>2-1</b>	<b>2-3</b>	<b>2-4</b>	<b>3-1</b>	<b>3-2</b>	<b>3-4</b>	<b>4-1</b>	<b>4-2</b>	<b>4-3</b>	<b>Zu. 1</b>	<b>Zu. 2</b>	<b>Zu. 3</b>	<b>Zu. 4</b>	<b>Ab. 1</b>	<b>Ab. 2</b>	<b>Ab. 3</b>	<b>Ab. 4</b>	<b>K-Sum</b>

## Summe Zählintervall 06:00 Uhr - 10:00 Uhr

FZ-ART	1-2	1-3	1-4	2-1	2-3	2-4	3-1	3-2	3-4	4-1	4-2	4-3	Zu. 1	Zu. 2	Zu. 3	Zu. 4	Ab. 1	Ab. 2	Ab. 3	Ab. 4	K-Sum
RAD	1	9	0	1	0	1	10	18	4	9	41	1	10	2	32	51	20	60	10	5	95
KRAD	0	3	2	0	7	0	0	5	0	3	4	3	5	7	5	10	3	9	13	2	27
PKW	6	309	27	9	258	39	217	214	45	17	196	290	342	306	476	503	243	416	857	111	1627
BUS	0	3	2	0	4	0	1	1	0	0	1	1	5	4	2	2	1	2	8	2	13
LFW	0	12	6	2	9	1	32	11	2	4	8	8	18	12	45	20	38	19	29	9	95
LKW	0	5	4	0	8	0	12	7	2	2	1	3	9	8	21	6	14	8	16	6	44
LZ	0	1	1	0	6	0	3	0	1	1	1	0	2	6	4	2	4	1	7	2	14
<b>KFZ</b>	<b>6</b>	<b>333</b>	<b>42</b>	<b>11</b>	<b>292</b>	<b>40</b>	<b>265</b>	<b>238</b>	<b>50</b>	<b>27</b>	<b>211</b>	<b>305</b>	<b>381</b>	<b>343</b>	<b>553</b>	<b>543</b>	<b>303</b>	<b>455</b>	<b>930</b>	<b>132</b>	<b>1820</b>
SV	0	9	7	0	18	0	16	8	3	3	3	4	16	18	27	10	19	11	31	10	71
PV	6	315	31	9	269	39	218	220	45	20	201	294	352	317	483	515	247	427	878	115	1667
GV	0	18	11	2	23	1	47	18	5	7	10	11	29	26	70	28	56	28	52	17	153
<b>FZ-ART</b>	<b>1-2</b>	<b>1-3</b>	<b>1-4</b>	<b>2-1</b>	<b>2-3</b>	<b>2-4</b>	<b>3-1</b>	<b>3-2</b>	<b>3-4</b>	<b>4-1</b>	<b>4-2</b>	<b>4-3</b>	<b>Zu. 1</b>	<b>Zu. 2</b>	<b>Zu. 3</b>	<b>Zu. 4</b>	<b>Ab. 1</b>	<b>Ab. 2</b>	<b>Ab. 3</b>	<b>Ab. 4</b>	<b>K-Sum</b>

## Summe Zählintervall 15:00 Uhr - 19:00 Uhr

FZ-ART	1-2	1-3	1-4	2-1	2-3	2-4	3-1	3-2	3-4	4-1	4-2	4-3	Zu. 1	Zu. 2	Zu. 3	Zu. 4	Ab. 1	Ab. 2	Ab. 3	Ab. 4	K-Sum
RAD	1	52	28	0	7	14	0	14	10	37	37	0	81	21	24	74	37	52	59	52	200
KRAD	0	12	5	1	11	0	0	13	0	16	4	2	17	12	13	22	17	17	25	5	64
PKW	6	337	5	21	414	143	400	378	127	14	165	196	348	578	905	375	435	549	947	275	2206
BUS	0	0	0	0	0	1	0	1	2	0	0	0	0	1	3	0	0	1	0	3	4
LFW	0	13	0	0	21	7	35	26	8	1	10	17	13	28	69	28	36	36	51	15	138
LKW	0	4	0	0	6	1	1	4	4	0	3	3	4	7	9	6	1	7	13	5	26
LZ	0	1	0	0	3	0	3	4	2	1	1	1	1	3	9	3	4	5	5	2	16
<b>KFZ</b>	<b>6</b>	<b>367</b>	<b>10</b>	<b>22</b>	<b>455</b>	<b>152</b>	<b>439</b>	<b>426</b>	<b>143</b>	<b>32</b>	<b>183</b>	<b>219</b>	<b>383</b>	<b>629</b>	<b>1008</b>	<b>434</b>	<b>493</b>	<b>615</b>	<b>1041</b>	<b>305</b>	<b>2454</b>
SV	0	5	0	0	9	2	4	9	8	1	4	4	5	11	21	9	5	13	18	10	46
PV	6	349	10	22	425	144	400	392	129	30	169	198	365	591	921	397	452	567	972	283	2274
GV	0	18	0	0	30	8	39	34	14	2	14	21	18	38	87	37	41	48	69	22	180
<b>FZ-ART</b>	<b>1-2</b>	<b>1-3</b>	<b>1-4</b>	<b>2-1</b>	<b>2-3</b>	<b>2-4</b>	<b>3-1</b>	<b>3-2</b>	<b>3-4</b>	<b>4-1</b>	<b>4-2</b>	<b>4-3</b>	<b>Zu. 1</b>	<b>Zu. 2</b>	<b>Zu. 3</b>	<b>Zu. 4</b>	<b>Ab. 1</b>	<b>Ab. 2</b>	<b>Ab. 3</b>	<b>Ab. 4</b>	<b>K-Sum</b>

## spezifische Spitzenstunde morgens 07:15 Uhr - 08:15 Uhr

FZ-ART	1-2	1-3	1-4	2-1	2-3	2-4	3-1	3-2	3-4	4-1	4-2	4-3	Zu. 1	Zu. 2	Zu. 3	Zu. 4	Ab. 1	Ab. 2	Ab. 3	Ab. 4	K-Sum
RAD	1	3	0	1	0	0	0	4	2	1	15	0	4	1	6	16	2	20	3	2	27
KRAD	0	0	1	0	3	0	0	2	0	2	1	2	1	3	2	5	2	3	5	1	11
PKW	4	131	13	2	96	6	85	58	2	3	64	127	148	104	145	194	90	126	354	21	591
BUS	0	1	2	0	3	0	0	0	0	0	0	0	3	3	0	0	0	0	0	2	6
LFW	0	3	1	0	3	1	6	4	1	0	3	0	4	4	11	3	6	7	6	3	22
LKW	0	2	3	0	2	0	1	2	0	0	1	0	5	2	3	1	1	3	4	3	11
LZ	0	0	0	0	4	0	1	0	0	0	0	0	0	4	1	0	1	0	4	0	5
<b>KFZ</b>	<b>4</b>	<b>137</b>	<b>20</b>	<b>2</b>	<b>111</b>	<b>7</b>	<b>93</b>	<b>66</b>	<b>3</b>	<b>5</b>	<b>69</b>	<b>129</b>	<b>161</b>	<b>120</b>	<b>162</b>	<b>203</b>	<b>100</b>	<b>139</b>	<b>377</b>	<b>30</b>	<b>646</b>
SV	0	3	5	0	9	0	2	2	0	0	1	0	8	9	4	1	2	3	12	5	22
PV	4	132	16	2	102	6	85	60	2	5	65	129	152	110	147	199	92	129	363	24	608
GV	0	5	4	0	9	1	8	6	1	0	4	0	9	10	15	4	8	10	14	6	38
<b>FZ-ART</b>	<b>1-2</b>	<b>1-3</b>	<b>1-4</b>	<b>2-1</b>	<b>2-3</b>	<b>2-4</b>	<b>3-1</b>	<b>3-2</b>	<b>3-4</b>	<b>4-1</b>	<b>4-2</b>	<b>4-3</b>	<b>Zu. 1</b>	<b>Zu. 2</b>	<b>Zu. 3</b>	<b>Zu. 4</b>	<b>Ab. 1</b>	<b>Ab. 2</b>	<b>Ab. 3</b>	<b>Ab. 4</b>	<b>K-Sum</b>

## spezifische Spitzenstunde abends 17:15 Uhr - 18:15 Uhr

FZ-ART	1-2	1-3	1-4	2-1	2-3	2-4	3-1	3-2	3-4	4-1	4-2	4-3	Zu. 1	Zu. 2	Zu. 3	Zu. 4	Ab. 1	Ab. 2	Ab. 3	Ab. 4	K-Sum
RAD	1	17	11	0	2	1	0	4	7	9	10	0	29	3	11	19	9	15	19	19	62
KRAD	0	6	2	0	2	0	0	5	0	4	0	1	8	2	5	5	4	5	9	2	20
PKW	1	101	1	2	109	30	113	116	36	4	53	45	103	141	265	102	119	170	255	67	611
BUS	0	0	0	0	0	0	0	0	0	0	0	0	0	0	0	0	0	0	0	0	0
LFW	0	4	0	0	5	2	12	7	2	0	3	3	4	7	21	6	12	10	12	4	38
LKW	0	0	0	0	1	0	0	0	0	0	0	0	0	1							



# Stadt Dachau

Zählstelle: K12 Gröbenrieder Straße / Himmelreichweg

Zusammenfassung Stundengruppen

Zähltag: Di., 24.04.2007

Zu-/Ablauf 1: Uhdestr.

Zu-/Ablauf 2: Gröbenrieder Str. (von/nach Stadteinwärts)

Zu-/Ablauf 3: Gröbenrieder Str. (von/nach Stadtauswärts)

Zu-/Ablauf 4: Himmelreichweg

Spezifische Spitzenstunde morgens  
07:15 Uhr - 08:15 Uhr in KFZ

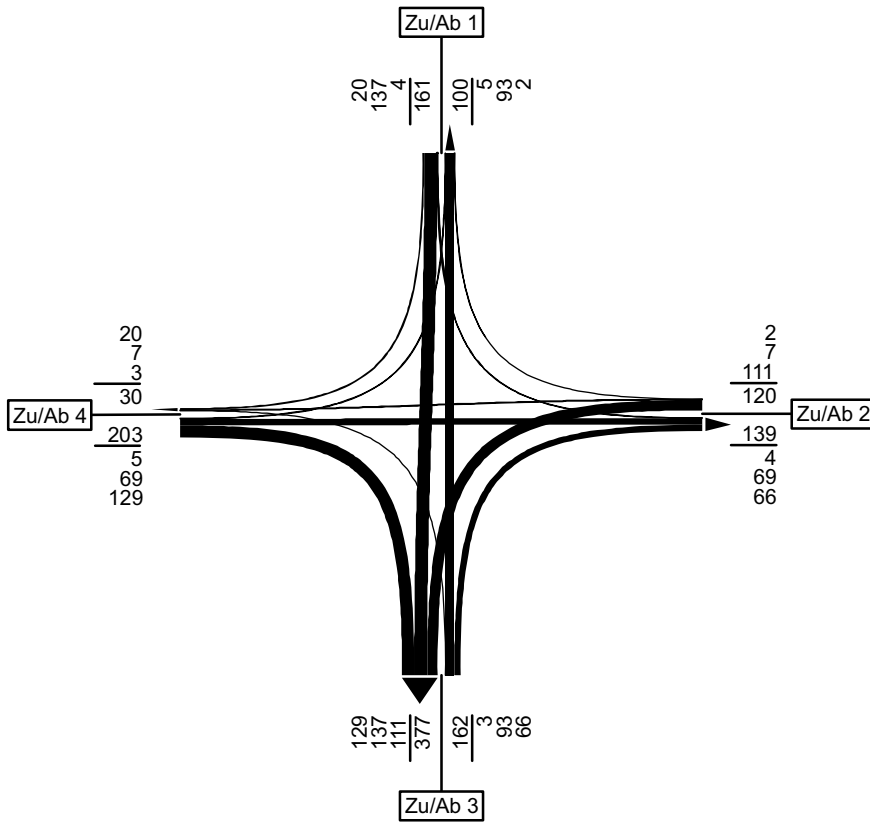

Spezifische Spitzenstunde abends  
17:15 Uhr - 18:15 Uhr in KFZ

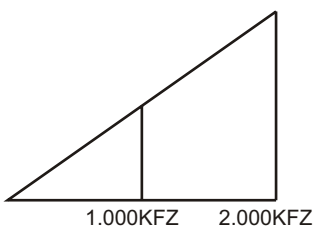
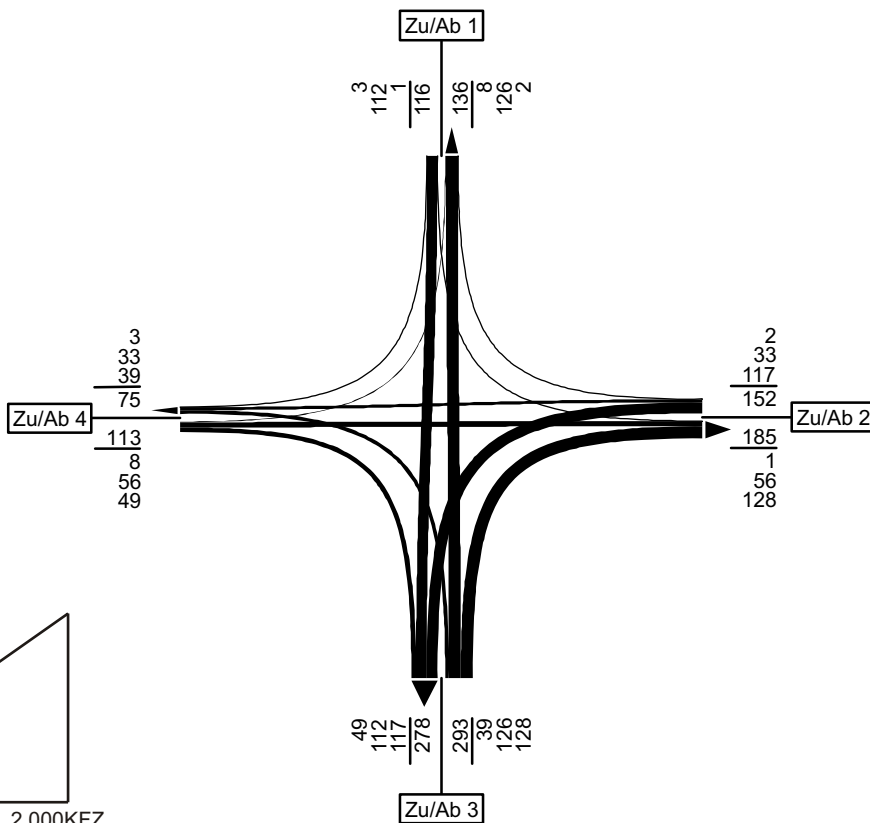

**Stadt Dachau**

Zählstelle: K13 Gröbenrieder Straße / Eduard-Ziegler-Straße

Zu-/Ablauf 1: Gröbenrieder Str. (von/nach Stadteinwärts)  
 Zu-/Ablauf 2: Eduard-Ziegler-Str.  
 Zu-/Ablauf 3: Gröbenrieder Str. (von/nach Stadtauswärts)  
 Zu-/Ablauf 4: Gündinger Str.

Zusammenfassung Stundengruppen

Zähltag: Di., 24.04.2007

Zählzeit: 06:00 Uhr - 10:00 Uhr und 15:00 Uhr - 19:00 Uhr

**Summe Zählzeit (06:00 Uhr - 10:00 Uhr und 15:00 Uhr - 19:00 Uhr)**

FZ-ART	1-2	1-3	1-4	2-1	2-3	2-4	3-1	3-2	3-4	4-1	4-2	4-3	Zu. 1	Zu. 2	Zu. 3	Zu. 4	Ab. 1	Ab. 2	Ab. 3	Ab. 4	K-Sum
RAD	43	40	27	22	0	3	39	5	4	3	8	5	110	25	48	16	64	56	45	34	199
KRAD	17	30	0	10	7	2	26	3	1	0	2	0	47	19	30	2	36	22	37	3	98
PKW	400	1162	42	282	100	8	1171	112	15	45	7	36	1604	390	1298	88	1498	519	1298	65	3380
BUS	1	8	0	0	0	0	2	0	0	0	0	0	9	0	2	0	2	1	8	0	11
LFW	14	78	12	12	8	0	73	0	3	8	0	1	104	20	76	9	93	14	87	15	209
LKW	1	24	3	3	0	0	29	0	2	3	0	1	28	3	31	4	35	1	25	5	66
LZ	2	9	1	1	0	0	8	1	2	0	0	1	12	1	11	1	9	3	10	3	25
<b>KFZ</b>	<b>435</b>	<b>1311</b>	<b>58</b>	<b>308</b>	<b>115</b>	<b>10</b>	<b>1309</b>	<b>116</b>	<b>23</b>	<b>56</b>	<b>9</b>	<b>39</b>	<b>1804</b>	<b>433</b>	<b>1448</b>	<b>104</b>	<b>1673</b>	<b>560</b>	<b>1465</b>	<b>91</b>	<b>3789</b>
SV	4	41	4	4	0	0	39	1	4	3	0	2	49	4	44	5	46	5	43	8	102
PV	418	1200	42	292	107	10	1199	115	16	45	9	36	1660	409	1330	90	1536	542	1343	68	3489
GV	17	111	16	16	8	0	110	1	7	11	0	3	144	24	118	14	137	18	122	23	300
<b>FZ-ART</b>	<b>1-2</b>	<b>1-3</b>	<b>1-4</b>	<b>2-1</b>	<b>2-3</b>	<b>2-4</b>	<b>3-1</b>	<b>3-2</b>	<b>3-4</b>	<b>4-1</b>	<b>4-2</b>	<b>4-3</b>	<b>Zu. 1</b>	<b>Zu. 2</b>	<b>Zu. 3</b>	<b>Zu. 4</b>	<b>Ab. 1</b>	<b>Ab. 2</b>	<b>Ab. 3</b>	<b>Ab. 4</b>	<b>K-Sum</b>

**Summe Zählintervall 06:00 Uhr - 10:00 Uhr**

FZ-ART	1-2	1-3	1-4	2-1	2-3	2-4	3-1	3-2	3-4	4-1	4-2	4-3	Zu. 1	Zu. 2	Zu. 3	Zu. 4	Ab. 1	Ab. 2	Ab. 3	Ab. 4	K-Sum
RAD	15	7	3	15	0	1	12	2	0	2	3	0	25	16	14	5	29	20	7	4	60
KRAD	7	11	0	2	1	2	5	2	1	0	1	0	18	5	8	1	7	10	12	3	32
PKW	224	533	23	137	41	3	379	36	4	18	4	23	780	181	419	45	534	264	597	30	1425
BUS	1	8	0	0	0	0	1	0	0	0	0	0	9	0	1	0	1	1	8	0	10
LFW	6	52	7	7	3	0	28	0	3	5	0	1	65	10	31	6	40	6	56	10	112
LKW	0	15	0	2	0	0	17	0	1	2	0	0	15	2	18	2	21	0	15	1	37
LZ	2	5	0	0	0	0	3	1	1	0	0	1	7	0	5	1	3	3	6	1	13
<b>KFZ</b>	<b>240</b>	<b>624</b>	<b>30</b>	<b>148</b>	<b>45</b>	<b>5</b>	<b>433</b>	<b>39</b>	<b>10</b>	<b>25</b>	<b>5</b>	<b>25</b>	<b>894</b>	<b>198</b>	<b>482</b>	<b>55</b>	<b>606</b>	<b>284</b>	<b>694</b>	<b>45</b>	<b>1629</b>
SV	3	28	0	2	0	0	21	1	2	2	0	1	31	2	24	3	25	4	29	2	60
PV	232	552	23	139	42	5	385	38	5	18	5	23	807	186	428	46	542	275	617	33	1467
GV	8	72	7	9	3	0	48	1	5	7	0	2	87	12	54	9	64	9	77	12	162
<b>FZ-ART</b>	<b>1-2</b>	<b>1-3</b>	<b>1-4</b>	<b>2-1</b>	<b>2-3</b>	<b>2-4</b>	<b>3-1</b>	<b>3-2</b>	<b>3-4</b>	<b>4-1</b>	<b>4-2</b>	<b>4-3</b>	<b>Zu. 1</b>	<b>Zu. 2</b>	<b>Zu. 3</b>	<b>Zu. 4</b>	<b>Ab. 1</b>	<b>Ab. 2</b>	<b>Ab. 3</b>	<b>Ab. 4</b>	<b>K-Sum</b>

**Summe Zählintervall 15:00 Uhr - 19:00 Uhr**

FZ-ART	1-2	1-3	1-4	2-1	2-3	2-4	3-1	3-2	3-4	4-1	4-2	4-3	Zu. 1	Zu. 2	Zu. 3	Zu. 4	Ab. 1	Ab. 2	Ab. 3	Ab. 4	K-Sum
RAD	28	33	24	7	0	2	27	3	4	1	5	5	85	9	34	11	35	36	38	30	139
KRAD	10	19	0	8	6	0	21	1	0	0	1	0	29	14	22	1	29	12	25	0	66
PKW	176	629	19	145	59	5	792	76	11	27	3	13	824	209	879	43	964	255	701	35	1955
BUS	0	0	0	0	0	0	1	0	0	0	0	0	0	0	1	0	1	0	0	0	1
LFW	8	26	5	5	5	0	45	0	0	3	0	0	39	10	45	3	53	8	31	5	97
LKW	1	9	3	1	0	0	12	0	1	1	0	1	13	1	13	2	14	1	10	4	29
LZ	0	4	1	1	0	0	5	0	1	0	0	0	5	1	6	0	6	0	4	2	12
<b>KFZ</b>	<b>195</b>	<b>687</b>	<b>28</b>	<b>160</b>	<b>70</b>	<b>5</b>	<b>876</b>	<b>77</b>	<b>13</b>	<b>31</b>	<b>4</b>	<b>14</b>	<b>910</b>	<b>235</b>	<b>966</b>	<b>49</b>	<b>1067</b>	<b>276</b>	<b>771</b>	<b>46</b>	<b>2160</b>
SV	1	13	4	2	0	0	18	0	2	1	0	1	18	2	20	2	21	1	14	6	42
PV	186	648	19	153	65	5	814	77	11	27	4	13	853	223	902	44	994	267	726	35	2022
GV	9	39	9	7	5	0	62	0	2	4	0	1	57	12	64	5	73	9	45	11	138
<b>FZ-ART</b>	<b>1-2</b>	<b>1-3</b>	<b>1-4</b>	<b>2-1</b>	<b>2-3</b>	<b>2-4</b>	<b>3-1</b>	<b>3-2</b>	<b>3-4</b>	<b>4-1</b>	<b>4-2</b>	<b>4-3</b>	<b>Zu. 1</b>	<b>Zu. 2</b>	<b>Zu. 3</b>	<b>Zu. 4</b>	<b>Ab. 1</b>	<b>Ab. 2</b>	<b>Ab. 3</b>	<b>Ab. 4</b>	<b>K-Sum</b>

**spezifische Spitzenstunde morgens 07:30 Uhr - 08:30 Uhr**

FZ-ART	1-2	1-3	1-4	2-1	2-3	2-4	3-1	3-2	3-4	4-1	4-2	4-3	Zu. 1	Zu. 2	Zu. 3	Zu. 4	Ab. 1	Ab. 2	Ab. 3	Ab. 4	K-Sum
RAD	3	1	0	5	0	0	6	2	0	1	2	0	4	5	8	3	12	7	1	0	20
KRAD	3	3	0	1	0	1	4	0	0	0	0	0	6	2	4	0	5	3	3	1	12
PKW	117	187	10	72	7	3	115	18	1	11	3	5	314	82	134	19	198	138	199	14	549
BUS	0	0	0	0	0	0	0	0	0	0	0	0	0	0	0	0	0	0	0	0	0
LFW	2	16	3	4	2	0	10	0	3	3	0	0	21	6	13	3	17	2	18	6	43
LKW	0	2	0	0	0	0	4	0	1	1	0	0	3	0	5	1	5	0	3	1	9
LZ	2	2	0	0	0	0	0	0	0	0	0	0	4	0	0	0	0	2	2	0	4
<b>KFZ</b>	<b>124</b>	<b>216</b>	<b>13</b>	<b>77</b>	<b>9</b>	<b>4</b>	<b>133</b>	<b>18</b>	<b>5</b>	<b>15</b>	<b>3</b>	<b>5</b>	<b>353</b>	<b>90</b>	<b>156</b>	<b>23</b>	<b>225</b>	<b>145</b>	<b>230</b>	<b>22</b>	<b>622</b>
SV	2	10	0	0	0	0	4	0	1	1	0	0	12	0	5	1	5	2	10	1	18
PV	120	195	10	73	7	4	119	18	1	11	3	5	325	84	138	19	203	141	207	15	566
GV	4	21	3	4	2	0	14	0	4	4	0	0	28	6	18	4	22	4	23	7	56
<b>FZ-ART</b>	<b>1-2</b>	<b>1-3</b>	<b>1-4</b>	<b>2-1</b>	<b>2-3</b>	<b>2-4</b>	<b>3-1</b>	<b>3-2</b>	<b>3-4</b>	<b>4-1</b>	<b>4-2</b>	<b>4-3</b>	<b>Zu. 1</b>	<b>Zu. 2</b>	<b>Zu. 3</b>	<b>Zu. 4</b>	<b>Ab. 1</b>	<b>Ab. 2</b>	<b>Ab. 3</b>	<b>Ab. 4</b>	<b>K-Sum</b>

**spezifische Spitzenstunde abends 17:15 Uhr - 18:15 Uhr**

FZ-ART	1-2	1-3	1-4	2-1	2-3	2-4	3-1	3-2	3-4	4-1	4-2	4-3	Zu. 1	Zu. 2	Zu. 3	Zu. 4	Ab. 1	Ab. 2	Ab. 3	Ab. 4	K-Sum
RAD	10	14	9	3	0	0	6	1	0	0	3	3	33	3	7	6	9	14	17	9	49
KRAD	2	9	0	4	0	0	7	0	0	0	1	0	11	4	7	1	11	3	9	0	23
PKW	49	179	5	33	17	1	268	30	6	8	2	4	233	51	304	14	309	81	200	12	602
BUS	0	0	0	0	0	0	0	0	0	0	0	0	0	0	0	0	0	0	0	0	0
LFW	2	8	1	1	1	0	9	0	0	1	0	0	11	2	9	1	11	2	9	1	23
LKW	0	0	0	0	0	0	5	0	0	0	0	0	0	0	5	0	5	0	0	0	5
LZ	0	2	0	0	0	0	1	0	0	0	0	0	2	0							

# Stadt Dachau

Zählstelle: K13 Gröbenrieder Straße / Eduard-Ziegler-Straße

Zusammenfassung Stundengruppen

Zähltag: Di., 24.04.2007

Zu-/Ablauf 1: Gröbenrieder Str. (von/nach Stadteinwärts)

Zu-/Ablauf 2: Eduard-Ziegler-Str.

Zu-/Ablauf 3: Gröbenrieder Str. (von/nach Stadtauswärts)

Zu-/Ablauf 4: Gündinger Str.

Spezifische Spitzenstunde morgens  
07:30 Uhr - 08:30 Uhr in KFZ

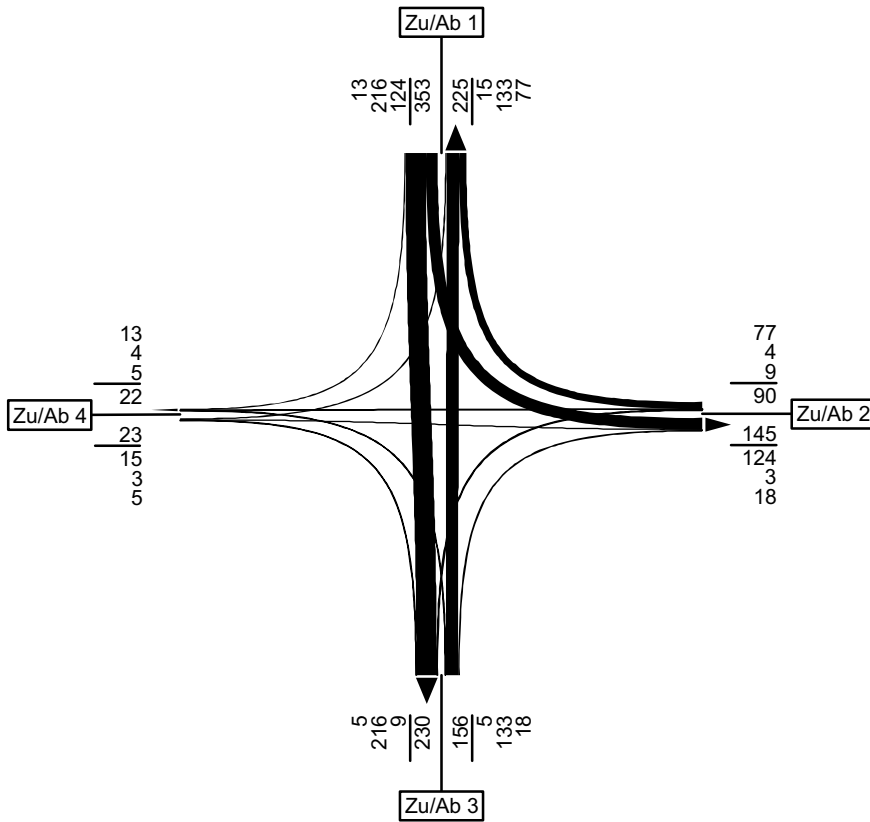

Spezifische Spitzenstunde abends  
17:15 Uhr - 18:15 Uhr in KFZ

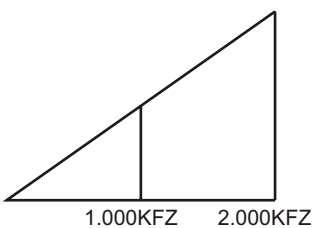
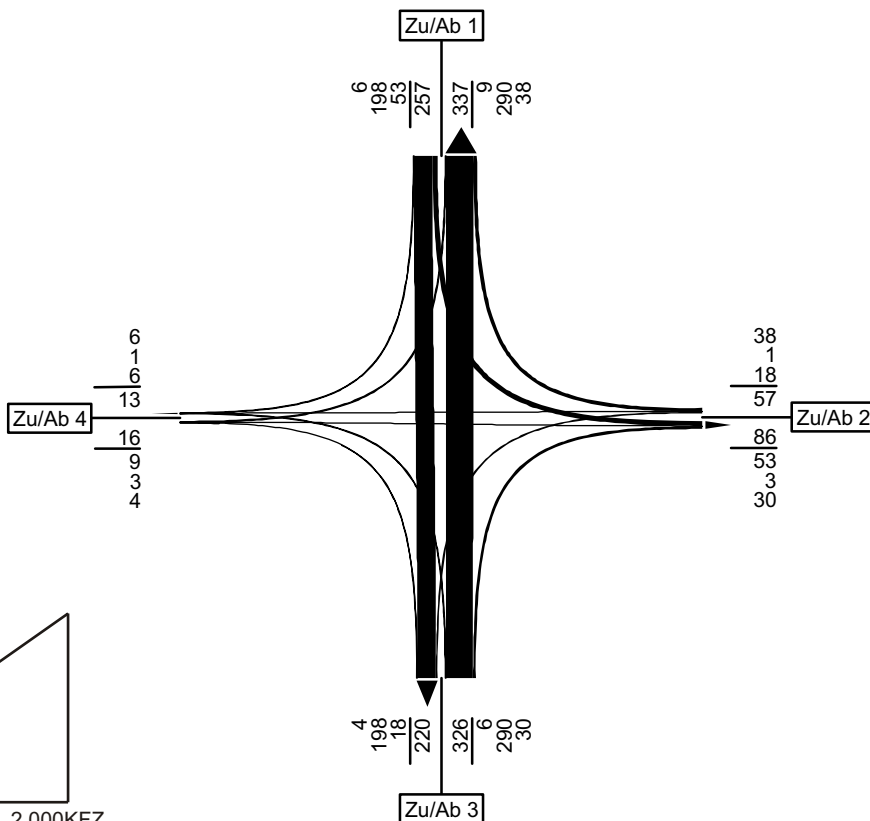

**Stadt Dachau**

Zählstelle: K14 Gröbenrieder Straße / Emmeringer Straße

Zu-/Ablauf 1: Gröbenrieder Str. (von/nach Stadteinwärts)

Zu-/Ablauf 2: Emmeringer Str.

Zu-/Ablauf 3: Gröbenrieder Str. (von/nach Stadtauswärts)

Zusammenfassung Stundengruppen

Zähltag: Di., 24.04.2007

Zählzeit: 06:00 Uhr - 10:00 Uhr und 15:00 Uhr - 19:00 Uhr

**Summe Zähizeit (06:00 Uhr - 10:00 Uhr und 15:00 Uhr - 19:00 Uhr)**

FZ-ART	1-2	1-3	1-4	2-1	2-3	2-4	3-1	3-2	3-4	4-1	4-2	4-3	Zu. 1	Zu. 2	Zu. 3	Zu. 4	Ab. 1	Ab. 2	Ab. 3	Ab. 4	K-Sum
RAD	0	20	0	0	5	0	22	4	0	0	0	0	20	5	26	0	22	4	25	0	51
KRAD	6	22	0	5	7	0	23	9	0	0	0	0	28	12	32	0	28	15	29	0	72
PKW	58	1018	0	56	269	0	1094	218	0	0	0	0	1076	325	1312	0	1150	276	1287	0	2713
BUS	0	4	0	0	0	0	2	0	0	0	0	0	4	0	2	0	2	0	4	0	6
LFW	5	49	0	9	16	0	44	16	0	0	0	0	54	25	60	0	53	21	65	0	139
LKW	0	12	0	2	2	0	21	0	0	0	0	0	12	4	21	0	23	0	14	0	37
LZ	6	22	0	3	3	0	16	4	0	0	0	0	28	6	20	0	19	10	25	0	54
<b>KFZ</b>	<b>75</b>	<b>1127</b>	<b>0</b>	<b>75</b>	<b>297</b>	<b>0</b>	<b>1200</b>	<b>247</b>	<b>0</b>	<b>0</b>	<b>0</b>	<b>0</b>	<b>1202</b>	<b>372</b>	<b>1447</b>	<b>0</b>	<b>1275</b>	<b>322</b>	<b>1424</b>	<b>0</b>	<b>3021</b>
SV	6	38	0	5	5	0	39	4	0	0	0	0	44	10	43	0	44	10	43	0	97
PV	64	1044	0	61	276	0	1119	227	0	0	0	0	1108	337	1346	0	1180	291	1320	0	2791
GV	11	83	0	14	21	0	81	20	0	0	0	0	94	35	101	0	95	31	104	0	230
<b>FZ-ART</b>	<b>1-2</b>	<b>1-3</b>	<b>1-4</b>	<b>2-1</b>	<b>2-3</b>	<b>2-4</b>	<b>3-1</b>	<b>3-2</b>	<b>3-4</b>	<b>4-1</b>	<b>4-2</b>	<b>4-3</b>	<b>Zu. 1</b>	<b>Zu. 2</b>	<b>Zu. 3</b>	<b>Zu. 4</b>	<b>Ab. 1</b>	<b>Ab. 2</b>	<b>Ab. 3</b>	<b>Ab. 4</b>	<b>K-Sum</b>

**Summe Zählintervall 06:00 Uhr - 10:00 Uhr**

FZ-ART	1-2	1-3	1-4	2-1	2-3	2-4	3-1	3-2	3-4	4-1	4-2	4-3	Zu. 1	Zu. 2	Zu. 3	Zu. 4	Ab. 1	Ab. 2	Ab. 3	Ab. 4	K-Sum
RAD	0	6	0	0	1	0	3	0	0	0	0	0	6	1	3	0	3	0	7	0	10
KRAD	2	9	0	2	5	0	4	2	0	0	0	0	11	7	6	0	6	4	14	0	24
PKW	17	572	0	20	181	0	343	43	0	0	0	0	589	201	386	0	363	60	753	0	1176
BUS	0	4	0	0	0	0	1	0	0	0	0	0	4	0	1	0	1	0	4	0	5
LFW	1	31	0	5	6	0	17	6	0	0	0	0	32	11	23	0	22	7	37	0	66
LKW	0	8	0	0	0	0	15	0	0	0	0	0	8	0	15	0	15	0	8	0	23
LZ	2	14	0	0	0	0	10	1	0	0	0	0	16	0	11	0	10	3	14	0	27
<b>KFZ</b>	<b>22</b>	<b>638</b>	<b>0</b>	<b>27</b>	<b>192</b>	<b>0</b>	<b>390</b>	<b>52</b>	<b>0</b>	<b>0</b>	<b>0</b>	<b>0</b>	<b>660</b>	<b>219</b>	<b>442</b>	<b>0</b>	<b>417</b>	<b>74</b>	<b>830</b>	<b>0</b>	<b>1321</b>
SV	2	26	0	0	0	0	26	1	0	0	0	0	28	0	27	0	26	3	26	0	55
PV	19	585	0	22	186	0	348	45	0	0	0	0	604	208	393	0	370	64	771	0	1205
GV	3	53	0	5	6	0	42	7	0	0	0	0	56	11	49	0	47	10	59	0	116
<b>FZ-ART</b>	<b>1-2</b>	<b>1-3</b>	<b>1-4</b>	<b>2-1</b>	<b>2-3</b>	<b>2-4</b>	<b>3-1</b>	<b>3-2</b>	<b>3-4</b>	<b>4-1</b>	<b>4-2</b>	<b>4-3</b>	<b>Zu. 1</b>	<b>Zu. 2</b>	<b>Zu. 3</b>	<b>Zu. 4</b>	<b>Ab. 1</b>	<b>Ab. 2</b>	<b>Ab. 3</b>	<b>Ab. 4</b>	<b>K-Sum</b>

**Summe Zählintervall 15:00 Uhr - 19:00 Uhr**

FZ-ART	1-2	1-3	1-4	2-1	2-3	2-4	3-1	3-2	3-4	4-1	4-2	4-3	Zu. 1	Zu. 2	Zu. 3	Zu. 4	Ab. 1	Ab. 2	Ab. 3	Ab. 4	K-Sum
RAD	0	14	0	0	1	0	19	4	0	0	0	0	14	4	23	0	19	4	18	0	41
KRAD	4	13	0	3	2	0	19	7	0	0	0	0	17	5	26	0	22	11	15	0	48
PKW	41	446	0	36	88	0	751	175	0	0	0	0	487	124	926	0	787	216	534	0	1537
BUS	0	4	0	0	0	0	1	0	0	0	0	0	0	0	1	0	1	0	0	0	1
LFW	4	18	0	4	10	0	27	10	0	0	0	0	22	14	37	0	31	14	28	0	73
LKW	0	4	0	2	2	0	6	0	0	0	0	0	4	4	6	0	8	0	6	0	14
LZ	4	8	0	3	3	0	6	3	0	0	0	0	12	6	9	0	9	7	11	0	27
<b>KFZ</b>	<b>53</b>	<b>489</b>	<b>0</b>	<b>48</b>	<b>105</b>	<b>0</b>	<b>810</b>	<b>195</b>	<b>0</b>	<b>0</b>	<b>0</b>	<b>0</b>	<b>542</b>	<b>153</b>	<b>1005</b>	<b>0</b>	<b>858</b>	<b>248</b>	<b>594</b>	<b>0</b>	<b>1700</b>
SV	4	12	0	5	5	0	13	3	0	0	0	0	16	10	16	0	18	7	17	0	42
PV	45	459	0	39	90	0	771	182	0	0	0	0	504	129	953	0	810	227	549	0	1586
GV	8	30	0	9	15	0	39	13	0	0	0	0	38	24	52	0	48	21	45	0	114
<b>FZ-ART</b>	<b>1-2</b>	<b>1-3</b>	<b>1-4</b>	<b>2-1</b>	<b>2-3</b>	<b>2-4</b>	<b>3-1</b>	<b>3-2</b>	<b>3-4</b>	<b>4-1</b>	<b>4-2</b>	<b>4-3</b>	<b>Zu. 1</b>	<b>Zu. 2</b>	<b>Zu. 3</b>	<b>Zu. 4</b>	<b>Ab. 1</b>	<b>Ab. 2</b>	<b>Ab. 3</b>	<b>Ab. 4</b>	<b>K-Sum</b>

**spezifische Spitzenstunde morgens 07:00 Uhr - 08:00 Uhr**

FZ-ART	1-2	1-3	1-4	2-1	2-3	2-4	3-1	3-2	3-4	4-1	4-2	4-3	Zu. 1	Zu. 2	Zu. 3	Zu. 4	Ab. 1	Ab. 2	Ab. 3	Ab. 4	K-Sum
RAD	0	3	0	0	1	0	0	0	0	0	0	0	3	1	0	0	0	0	4	0	4
KRAD	1	3	0	0	3	0	3	0	0	0	0	0	4	3	3	0	3	1	6	0	10
PKW	2	237	0	3	72	0	103	7	0	0	0	0	239	75	110	0	106	9	309	0	424
BUS	0	1	0	0	0	0	0	0	0	0	0	0	1	0	0	0	0	0	1	0	1
LFW	0	6	0	3	2	0	7	3	0	0	0	0	6	5	10	0	10	3	8	0	21
LKW	0	4	0	0	0	0	5	0	0	0	0	0	4	0	5	0	5	0	4	0	9
LZ	0	5	0	0	0	0	2	0	0	0	0	0	5	0	2	0	2	0	5	0	7
<b>KFZ</b>	<b>3</b>	<b>256</b>	<b>0</b>	<b>6</b>	<b>77</b>	<b>0</b>	<b>120</b>	<b>10</b>	<b>0</b>	<b>0</b>	<b>0</b>	<b>0</b>	<b>259</b>	<b>83</b>	<b>130</b>	<b>0</b>	<b>126</b>	<b>13</b>	<b>333</b>	<b>0</b>	<b>472</b>
SV	0	10	0	0	0	0	7	0	0	0	0	0	10	0	7	0	7	0	10	0	17
PV	3	241	0	3	75	0	106	7	0	0	0	0	244	78	113	0	109	10	316	0	435
GV	0	15	0	3	2	0	14	3	0	0	0	0	15	5	17	0	17	3	17	0	37
<b>FZ-ART</b>	<b>1-2</b>	<b>1-3</b>	<b>1-4</b>	<b>2-1</b>	<b>2-3</b>	<b>2-4</b>	<b>3-1</b>	<b>3-2</b>	<b>3-4</b>	<b>4-1</b>	<b>4-2</b>	<b>4-3</b>	<b>Zu. 1</b>	<b>Zu. 2</b>	<b>Zu. 3</b>	<b>Zu. 4</b>	<b>Ab. 1</b>	<b>Ab. 2</b>	<b>Ab. 3</b>	<b>Ab. 4</b>	<b>K-Sum</b>

**spezifische Spitzenstunde abends 17:00 Uhr - 18:00 Uhr**

FZ-ART	1-2	1-3	1-4	2-1	2-3	2-4	3-1	3-2	3-4	4-1	4-2	4-3	Zu. 1	Zu. 2	Zu. 3	Zu. 4	Ab. 1	Ab. 2	Ab. 3	Ab. 4	K-Sum
RAD	0	5	0	0	3	0	6	2	0	0	0	0	5	3	8	0	6	2	8	0	16
KRAD	2	2	0	1	0	0	5	3	0	0	0	0	4	1	8	0	6	5	2	0	13
PKW	14	128	0	19	28	0	254	45	0	0	0	0	142	47	299	0	273	59	156	0	488
BUS	0	0	0	0	0	0	0	0	0	0	0	0	0	0	0	0	0	0	0	0	0
LFW	1	6	0	0	0	0	8	4	0	0	0	0	7	0	12	0	8	5	6	0	19
LKW	0	0	0	0	0	0	2	0	0	0	0	0	0	0	2	0	2	0	0	0	2
LZ	2	1	0	0	1	0	1	1	0	0	0	0	3	1	2	0	1	3	2	0	6
<b>KFZ</b>	<b>19</b>	<b>137</b>	<b>0</b> </																		

# Stadt Dachau

Zählstelle: K14 Gröbenrieder Straße / Emmeringer Straße

Zusammenfassung Stundengruppen

Zähltag: Di., 24.04.2007

Zu-/Ablauf 1: Gröbenrieder Str. (von/nach Stadteinwärts)

Zu-/Ablauf 2: Emmeringer Str.

Zu-/Ablauf 3: Gröbenrieder Str. (von/nach Stadtauswärts)

Spezifische Spitzenstunde morgens  
07:00 Uhr - 08:00 Uhr in KFZ

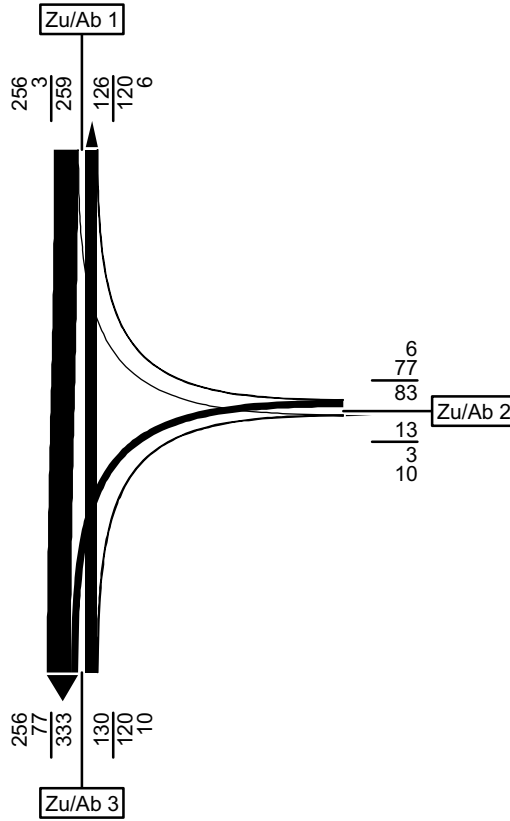

Spezifische Spitzenstunde abends  
17:00 Uhr - 18:00 Uhr in KFZ

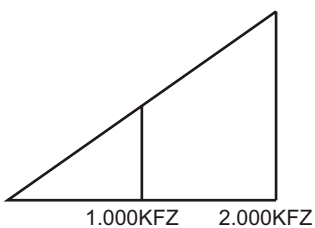
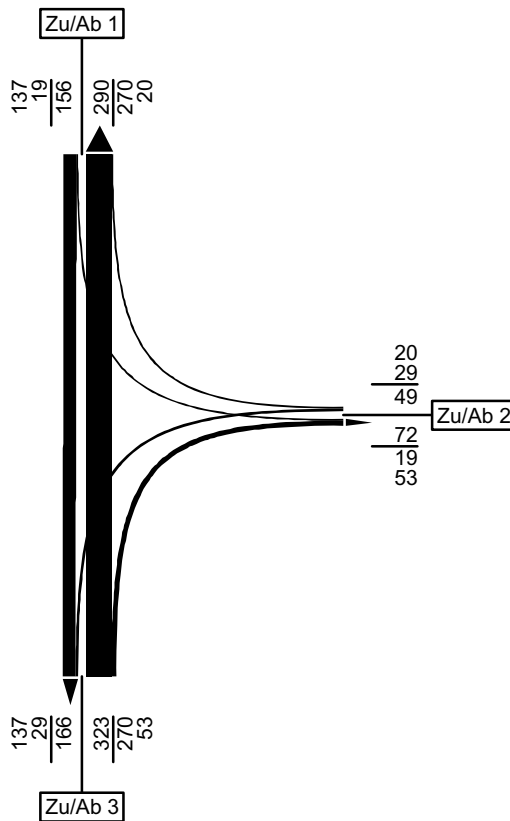



# Stadt Dachau

Zählstelle: K15 Langwieder Straße / Emmeringer Straße

Zusammenfassung Stundengruppen

Zähltag: Di., 24.04.2007

Zu-/Ablauf 1: Langwieder Str. (von/nach Stadteinwärts)

Zu-/Ablauf 2: Langwieder Str. (von/nach Stadtauswärts)

Zu-/Ablauf 3: Emmeringer Str.

Spezifische Spitzenstunde morgens  
07:00 Uhr - 08:00 Uhr in KFZ

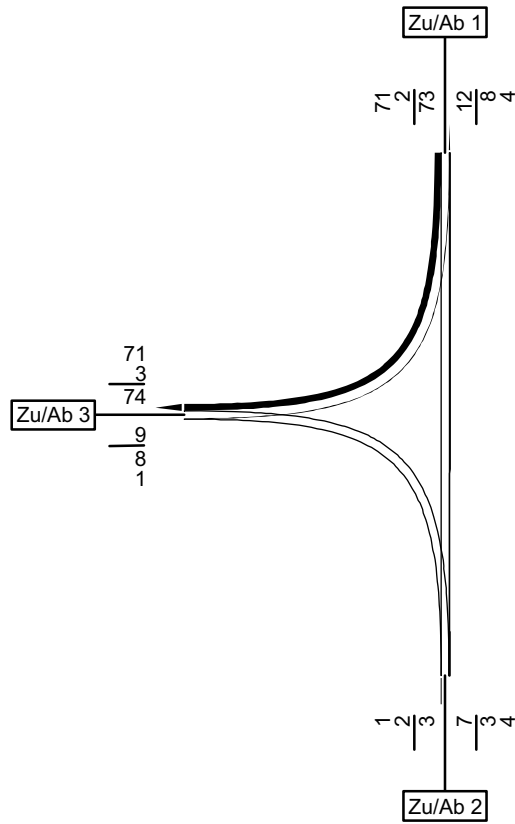

Spezifische Spitzenstunde abends  
17:00 Uhr - 18:00 Uhr in KFZ

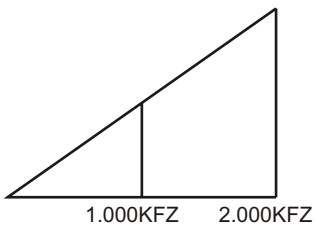
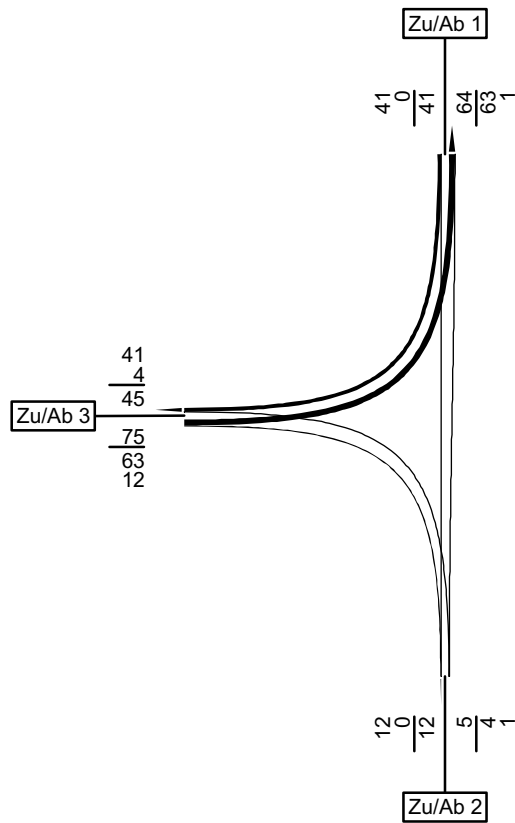

**Stadt Dachau**

Zählstelle: K16 Münchener Straße / Anton-Hechtl-Straße

Zu-/Ablauf 1: Münchener Str. (von/nach Stadtauswärts)

Zu-/Ablauf 2: Anton-Hechtl-Str.

Zu-/Ablauf 3: Münchener Str. (von/nach Stadteinwärts)

Zusammenfassung Stundengruppen

Zähltag: Di., 24.04.2007

Zählzeit: 06:00 Uhr - 10:00 Uhr und 15:00 Uhr - 19:00 Uhr

**Summe Zähizeit (06:00 Uhr - 10:00 Uhr und 15:00 Uhr - 19:00 Uhr)**

FZ-ART	1-2	1-3	1-4	2-1	2-3	2-4	3-1	3-2	3-4	4-1	4-2	4-3	Zu. 1	Zu. 2	Zu. 3	Zu. 4	Ab. 1	Ab. 2	Ab. 3	Ab. 4	K-Sum
RAD	3	269	0	50	73	0	6	81	0	0	0	0	272	123	87	0	56	84	342	0	482
KRAD	25	85	0	16	10	0	80	7	0	0	0	0	110	26	87	0	96	32	95	0	223
PKW	811	5698	0	1000	227	0	5867	258	0	0	0	0	6509	1227	6125	0	6867	1069	5925	0	13861
BUS	0	36	0	1	0	0	30	0	0	0	0	0	36	1	30	0	31	0	36	0	67
LFW	55	279	0	49	10	0	360	18	0	0	0	0	334	59	378	0	409	73	289	0	771
LKW	15	92	0	15	3	0	113	3	0	0	0	0	107	18	116	0	128	18	95	0	241
LZ	3	46	0	1	0	0	14	2	0	0	0	0	49	1	16	0	15	5	46	0	66
<b>KFZ</b>	<b>909</b>	<b>6236</b>	<b>0</b>	<b>1082</b>	<b>250</b>	<b>0</b>	<b>6464</b>	<b>288</b>	<b>0</b>	<b>0</b>	<b>0</b>	<b>0</b>	<b>7145</b>	<b>1332</b>	<b>6752</b>	<b>0</b>	<b>7546</b>	<b>1197</b>	<b>6486</b>	<b>0</b>	<b>15229</b>
SV	18	174	0	17	3	0	157	5	0	0	0	0	192	20	162	0	174	23	177	0	374
PV	836	5819	0	1017	237	0	5977	265	0	0	0	0	6655	1254	6242	0	6994	1101	6056	0	14151
GV	73	417	0	65	13	0	487	23	0	0	0	0	490	78	510	0	552	96	430	0	1078
<b>FZ-ART</b>	<b>1-2</b>	<b>1-3</b>	<b>1-4</b>	<b>2-1</b>	<b>2-3</b>	<b>2-4</b>	<b>3-1</b>	<b>3-2</b>	<b>3-4</b>	<b>4-1</b>	<b>4-2</b>	<b>4-3</b>	<b>Zu. 1</b>	<b>Zu. 2</b>	<b>Zu. 3</b>	<b>Zu. 4</b>	<b>Ab. 1</b>	<b>Ab. 2</b>	<b>Ab. 3</b>	<b>Ab. 4</b>	<b>K-Sum</b>

**Summe Zählintervall 06:00 Uhr - 10:00 Uhr**

FZ-ART	1-2	1-3	1-4	2-1	2-3	2-4	3-1	3-2	3-4	4-1	4-2	4-3	Zu. 1	Zu. 2	Zu. 3	Zu. 4	Ab. 1	Ab. 2	Ab. 3	Ab. 4	K-Sum
RAD	0	133	0	15	53	0	1	16	0	0	0	0	133	68	17	0	16	16	186	0	218
KRAD	7	16	0	8	7	0	48	2	0	0	0	0	23	15	50	0	56	9	23	0	88
PKW	182	1698	0	629	132	0	3400	83	0	0	0	0	1880	761	3483	0	4029	265	1830	0	6124
BUS	0	19	0	1	0	0	18	0	0	0	0	0	19	1	18	0	19	0	19	0	38
LFW	30	111	0	31	7	0	227	10	0	0	0	0	141	38	237	0	258	40	118	0	416
LKW	10	60	0	10	3	0	80	1	0	0	0	0	70	13	81	0	90	11	63	0	164
LZ	2	17	0	1	0	0	11	0	0	0	0	0	19	1	11	0	12	2	17	0	31
<b>KFZ</b>	<b>231</b>	<b>1921</b>	<b>0</b>	<b>680</b>	<b>149</b>	<b>0</b>	<b>3784</b>	<b>96</b>	<b>0</b>	<b>0</b>	<b>0</b>	<b>0</b>	<b>2152</b>	<b>829</b>	<b>3880</b>	<b>0</b>	<b>4464</b>	<b>327</b>	<b>2070</b>	<b>0</b>	<b>6861</b>
SV	12	96	0	12	3	0	109	1	0	0	0	0	108	15	110	0	121	13	99	0	233
PV	189	1733	0	638	139	0	3466	85	0	0	0	0	1922	777	3551	0	4104	274	1872	0	6250
GV	42	188	0	42	10	0	318	11	0	0	0	0	230	52	329	0	360	53	198	0	611
<b>FZ-ART</b>	<b>1-2</b>	<b>1-3</b>	<b>1-4</b>	<b>2-1</b>	<b>2-3</b>	<b>2-4</b>	<b>3-1</b>	<b>3-2</b>	<b>3-4</b>	<b>4-1</b>	<b>4-2</b>	<b>4-3</b>	<b>Zu. 1</b>	<b>Zu. 2</b>	<b>Zu. 3</b>	<b>Zu. 4</b>	<b>Ab. 1</b>	<b>Ab. 2</b>	<b>Ab. 3</b>	<b>Ab. 4</b>	<b>K-Sum</b>

**Summe Zählintervall 15:00 Uhr - 19:00 Uhr**

FZ-ART	1-2	1-3	1-4	2-1	2-3	2-4	3-1	3-2	3-4	4-1	4-2	4-3	Zu. 1	Zu. 2	Zu. 3	Zu. 4	Ab. 1	Ab. 2	Ab. 3	Ab. 4	K-Sum
RAD	3	136	0	35	20	0	5	65	0	0	0	0	139	55	70	0	40	68	156	0	264
KRAD	18	69	0	8	3	0	32	5	0	0	0	0	87	11	37	0	40	23	72	0	135
PKW	629	4000	0	371	95	0	2467	175	0	0	0	0	4629	466	2642	0	2838	804	4095	0	7737
BUS	0	17	0	0	0	0	12	0	0	0	0	0	17	0	12	0	12	0	17	0	29
LFW	25	168	0	18	3	0	133	8	0	0	0	0	193	21	141	0	151	33	171	0	355
LKW	5	32	0	5	0	0	33	2	0	0	0	0	37	5	35	0	38	7	32	0	77
LZ	1	29	0	0	0	0	3	2	0	0	0	0	30	0	5	0	3	3	29	0	35
<b>KFZ</b>	<b>678</b>	<b>4315</b>	<b>0</b>	<b>402</b>	<b>101</b>	<b>0</b>	<b>2680</b>	<b>192</b>	<b>0</b>	<b>0</b>	<b>0</b>	<b>0</b>	<b>4993</b>	<b>503</b>	<b>2872</b>	<b>0</b>	<b>3082</b>	<b>870</b>	<b>4416</b>	<b>0</b>	<b>8368</b>
SV	6	78	0	5	0	0	48	4	0	0	0	0	84	5	52	0	53	10	78	0	141
PV	647	4086	0	379	98	0	2511	180	0	0	0	0	4733	477	2691	0	2890	827	4184	0	7901
GV	31	229	0	23	3	0	169	12	0	0	0	0	260	26	181	0	192	43	232	0	467
<b>FZ-ART</b>	<b>1-2</b>	<b>1-3</b>	<b>1-4</b>	<b>2-1</b>	<b>2-3</b>	<b>2-4</b>	<b>3-1</b>	<b>3-2</b>	<b>3-4</b>	<b>4-1</b>	<b>4-2</b>	<b>4-3</b>	<b>Zu. 1</b>	<b>Zu. 2</b>	<b>Zu. 3</b>	<b>Zu. 4</b>	<b>Ab. 1</b>	<b>Ab. 2</b>	<b>Ab. 3</b>	<b>Ab. 4</b>	<b>K-Sum</b>

**spezifische Spitzenstunde morgens 07:30 Uhr - 08:30 Uhr**

FZ-ART	1-2	1-3	1-4	2-1	2-3	2-4	3-1	3-2	3-4	4-1	4-2	4-3	Zu. 1	Zu. 2	Zu. 3	Zu. 4	Ab. 1	Ab. 2	Ab. 3	Ab. 4	K-Sum
RAD	0	52	0	4	27	0	0	8	0	0	0	0	52	31	8	0	4	8	79	0	91
KRAD	2	5	0	3	3	0	6	2	0	0	0	0	7	6	8	0	9	4	8	0	21
PKW	71	569	0	207	54	0	984	33	0	0	0	0	640	261	1017	0	1191	104	623	0	1918
BUS	0	7	0	1	0	0	5	0	0	0	0	0	7	1	5	0	6	0	7	0	13
LFW	11	34	0	10	1	0	39	2	0	0	0	0	45	11	41	0	49	13	35	0	97
LKW	5	13	0	2	1	0	21	0	0	0	0	0	18	3	21	0	23	5	14	0	42
LZ	0	2	0	0	0	0	1	0	0	0	0	0	2	0	1	0	1	0	2	0	3
<b>KFZ</b>	<b>89</b>	<b>630</b>	<b>0</b>	<b>223</b>	<b>59</b>	<b>0</b>	<b>1056</b>	<b>37</b>	<b>0</b>	<b>0</b>	<b>0</b>	<b>0</b>	<b>719</b>	<b>282</b>	<b>1093</b>	<b>0</b>	<b>1279</b>	<b>126</b>	<b>689</b>	<b>0</b>	<b>2094</b>
SV	5	22	0	3	1	0	27	0	0	0	0	0	27	4	27	0	30	5	23	0	58
PV	73	581	0	211	57	0	995	35	0	0	0	0	654	268	1030	0	1206	108	638	0	1952
GV	16	49	0	12	2	0	61	2	0	0	0	0	65	14	63	0	73	18	51	0	142
<b>FZ-ART</b>	<b>1-2</b>	<b>1-3</b>	<b>1-4</b>	<b>2-1</b>	<b>2-3</b>	<b>2-4</b>	<b>3-1</b>	<b>3-2</b>	<b>3-4</b>	<b>4-1</b>	<b>4-2</b>	<b>4-3</b>	<b>Zu. 1</b>	<b>Zu. 2</b>	<b>Zu. 3</b>	<b>Zu. 4</b>	<b>Ab. 1</b>	<b>Ab. 2</b>	<b>Ab. 3</b>	<b>Ab. 4</b>	<b>K-Sum</b>

**spezifische Spitzenstunde abends 16:45 Uhr - 17:45 Uhr**

FZ-ART	1-2	1-3	1-4	2-1	2-3	2-4	3-1	3-2	3-4	4-1	4-2	4-3	Zu. 1	Zu. 2	Zu. 3	Zu. 4	Ab. 1	Ab. 2	Ab. 3	Ab. 4	K-Sum
RAD	0	37	0	9	5	0	1	18	0	0	0	0	37	14	19	0	10	18	42	0	70
KRAD	2	24	0	3	2	0	9	3	0	0	0	0	26	5	12	0	12	5	26	0	43
PKW	184	1130	0	109	24	0	686	43	0	0	0	0	1314	133	729	0	795	227	1154	0	2176
BUS	0	3	0	0	0	0	2	0	0	0	0	0	3	0	2	0	2	0	3	0	5
LFW	7	49	0	6	2	0	27	3	0	0	0	0	56	8	30	0	33	10	51	0	94
LKW	0	7	0	0	0	0	8														



# Stadt Dachau

Zählstelle: K16 Münchener Straße / Anton-Hechtl-Straße

Zusammenfassung Stundengruppen

Zähltag: Di., 24.04.2007

Zu-/Ablauf 1: Münchener Str. (von/nach Stadtauswärts)

Zu-/Ablauf 2: Anton-Hechtl-Str.

Zu-/Ablauf 3: Münchener Str. (von/nach Stadteinwärts)

Spezifische Spitzenstunde morgens  
07:30 Uhr - 08:30 Uhr in KFZ

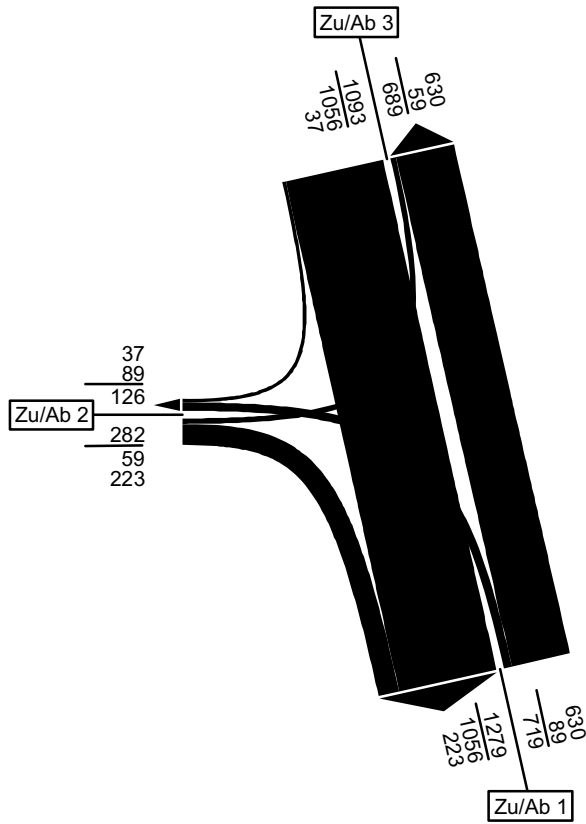

Spezifische Spitzenstunde abends  
16:45 Uhr - 17:45 Uhr in KFZ

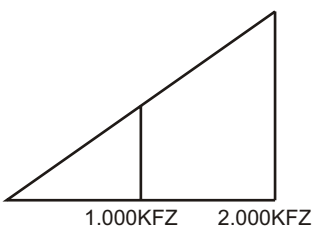
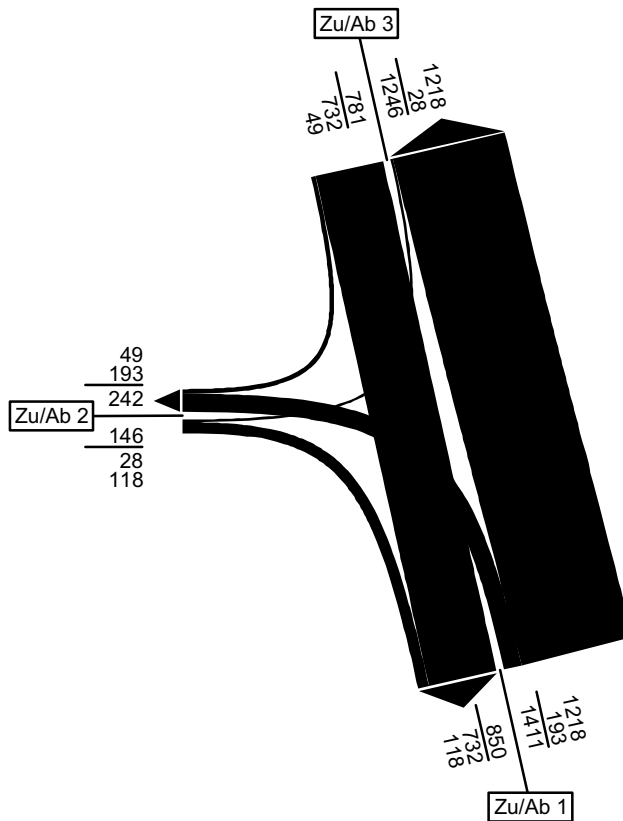

**Stadt Dachau**

Zählstelle: K17 Münchener Straße / Goethestraße

Zu-/Ablauf 1: Goethestr.

Zu-/Ablauf 2: Münchener Str. (von/nach Stadtauswärts)

Zu-/Ablauf 3: Hermann-Stockmann-Str.

Zu-/Ablauf 4: Münchener Str. (von/nach Stadteinwärts)

Zusammenfassung Stundengruppen

Zähltag: Di., 24.04.2007

Zählzeit: 06:00 Uhr - 10:00 Uhr und 15:00 Uhr - 19:00 Uhr

**Summe Zählzeit (06:00 Uhr - 10:00 Uhr und 15:00 Uhr - 19:00 Uhr)**

FZ-ART	1-2	1-3	1-4	2-1	2-3	2-4	3-1	3-2	3-4	4-1	4-2	4-3	Zu. 1	Zu. 2	Zu. 3	Zu. 4	Ab. 1	Ab. 2	Ab. 3	Ab. 4	K-Sum
RAD	3	64	10	0	12	330	0	0	61	0	98	93	77	342	61	191	0	101	169	401	671
KRAD	0	6	6	0	7	78	0	4	30	0	85	78	12	85	34	103	0	89	31	114	234
PKW	143	110	124	0	75	5829	0	183	1038	0	5960	710	377	5904	1221	6670	0	6286	895	6991	14172
BUS	0	0	0	0	0	50	0	0	25	0	92	26	0	50	25	118	0	92	26	75	193
LFW	8	4	8	0	1	305	0	8	27	0	402	44	20	306	35	446	0	418	49	340	807
LKW	0	0	1	0	1	97	0	3	4	0	114	11	1	98	7	125	0	117	12	102	231
LZ	0	0	0	0	3	39	0	0	1	0	32	1	0	42	1	33	0	32	4	40	76
<b>KFZ</b>	<b>151</b>	<b>120</b>	<b>139</b>	<b>0</b>	<b>87</b>	<b>6398</b>	<b>0</b>	<b>198</b>	<b>1125</b>	<b>0</b>	<b>6685</b>	<b>810</b>	<b>410</b>	<b>6485</b>	<b>1323</b>	<b>7495</b>	<b>0</b>	<b>7034</b>	<b>1017</b>	<b>7662</b>	<b>15713</b>
SV	0	0	1	0	4	186	0	3	30	0	238	38	1	190	33	276	0	241	42	217	500
PV	143	116	130	0	82	5957	0	187	1093	0	6137	754	389	6039	1280	6891	0	6467	952	7180	14599
GV	8	4	9	0	5	441	0	11	32	0	548	56	21	446	43	604	0	567	65	482	1114
<b>FZ-ART</b>	<b>1-2</b>	<b>1-3</b>	<b>1-4</b>	<b>2-1</b>	<b>2-3</b>	<b>2-4</b>	<b>3-1</b>	<b>3-2</b>	<b>3-4</b>	<b>4-1</b>	<b>4-2</b>	<b>4-3</b>	<b>Zu. 1</b>	<b>Zu. 2</b>	<b>Zu. 3</b>	<b>Zu. 4</b>	<b>Ab. 1</b>	<b>Ab. 2</b>	<b>Ab. 3</b>	<b>Ab. 4</b>	<b>K-Sum</b>

**Summe Zählintervall 06:00 Uhr - 10:00 Uhr**

FZ-ART	1-2	1-3	1-4	2-1	2-3	2-4	3-1	3-2	3-4	4-1	4-2	4-3	Zu. 1	Zu. 2	Zu. 3	Zu. 4	Ab. 1	Ab. 2	Ab. 3	Ab. 4	K-Sum
RAD	0	8	4	0	6	180	0	0	33	0	19	25	12	186	33	44	0	19	39	217	275
KRAD	0	0	2	0	1	15	0	4	14	0	40	5	2	16	18	45	0	44	6	31	81
PKW	62	37	28	0	28	1702	0	91	497	0	3456	237	127	1730	588	3693	0	3609	302	2227	6138
BUS	0	0	0	0	0	30	0	0	12	0	55	14	0	30	12	69	0	55	14	42	111
LFW	4	2	3	0	1	135	0	4	14	0	262	26	9	136	18	288	0	270	29	152	451
LKW	0	0	1	0	0	62	0	1	2	0	80	10	1	62	3	90	0	81	10	65	156
LZ	0	0	0	0	2	13	0	0	1	0	23	1	0	15	1	24	0	23	3	14	40
<b>KFZ</b>	<b>66</b>	<b>39</b>	<b>34</b>	<b>0</b>	<b>32</b>	<b>1957</b>	<b>0</b>	<b>100</b>	<b>540</b>	<b>0</b>	<b>3916</b>	<b>293</b>	<b>139</b>	<b>1989</b>	<b>640</b>	<b>4209</b>	<b>0</b>	<b>4082</b>	<b>364</b>	<b>2531</b>	<b>6977</b>
SV	0	0	1	0	2	105	0	1	15	0	158	25	1	107	16	183	0	159	27	121	307
PV	62	37	30	0	29	1747	0	95	523	0	3551	256	129	1776	618	3807	0	3708	322	2300	6330
GV	4	2	4	0	3	210	0	5	17	0	365	37	10	213	22	402	0	374	42	231	647
<b>FZ-ART</b>	<b>1-2</b>	<b>1-3</b>	<b>1-4</b>	<b>2-1</b>	<b>2-3</b>	<b>2-4</b>	<b>3-1</b>	<b>3-2</b>	<b>3-4</b>	<b>4-1</b>	<b>4-2</b>	<b>4-3</b>	<b>Zu. 1</b>	<b>Zu. 2</b>	<b>Zu. 3</b>	<b>Zu. 4</b>	<b>Ab. 1</b>	<b>Ab. 2</b>	<b>Ab. 3</b>	<b>Ab. 4</b>	<b>K-Sum</b>

**Summe Zählintervall 15:00 Uhr - 19:00 Uhr**

FZ-ART	1-2	1-3	1-4	2-1	2-3	2-4	3-1	3-2	3-4	4-1	4-2	4-3	Zu. 1	Zu. 2	Zu. 3	Zu. 4	Ab. 1	Ab. 2	Ab. 3	Ab. 4	K-Sum
RAD	3	56	6	0	6	150	0	0	28	0	79	68	65	156	28	147	0	82	130	184	396
KRAD	0	6	4	0	6	63	0	0	16	0	45	13	10	69	16	58	0	45	25	83	153
PKW	81	73	96	0	47	4127	0	92	541	0	2504	473	250	4174	633	2977	0	2677	593	4764	8034
BUS	0	0	0	0	0	20	0	0	13	0	37	12	0	20	13	49	0	37	12	33	82
LFW	4	2	5	0	0	170	0	4	13	0	140	18	11	170	17	158	0	148	20	188	356
LKW	0	0	0	0	1	35	0	2	2	0	34	1	0	36	4	35	0	36	2	37	75
LZ	0	0	0	0	1	26	0	0	0	0	9	0	0	27	0	9	0	9	1	26	36
<b>KFZ</b>	<b>85</b>	<b>81</b>	<b>105</b>	<b>0</b>	<b>55</b>	<b>4441</b>	<b>0</b>	<b>98</b>	<b>585</b>	<b>0</b>	<b>2769</b>	<b>517</b>	<b>271</b>	<b>4496</b>	<b>683</b>	<b>3286</b>	<b>0</b>	<b>2952</b>	<b>653</b>	<b>5131</b>	<b>8736</b>
SV	0	0	0	0	2	81	0	2	15	0	80	13	0	83	17	93	0	82	15	96	193
PV	81	79	100	0	53	4210	0	92	570	0	2586	498	260	4263	662	3084	0	2759	630	4880	8269
GV	4	2	5	0	2	231	0	6	15	0	183	19	11	233	21	202	0	193	23	251	467
<b>FZ-ART</b>	<b>1-2</b>	<b>1-3</b>	<b>1-4</b>	<b>2-1</b>	<b>2-3</b>	<b>2-4</b>	<b>3-1</b>	<b>3-2</b>	<b>3-4</b>	<b>4-1</b>	<b>4-2</b>	<b>4-3</b>	<b>Zu. 1</b>	<b>Zu. 2</b>	<b>Zu. 3</b>	<b>Zu. 4</b>	<b>Ab. 1</b>	<b>Ab. 2</b>	<b>Ab. 3</b>	<b>Ab. 4</b>	<b>K-Sum</b>

**spezifische Spitzenstunde morgens 07:15 Uhr - 08:15 Uhr**

FZ-ART	1-2	1-3	1-4	2-1	2-3	2-4	3-1	3-2	3-4	4-1	4-2	4-3	Zu. 1	Zu. 2	Zu. 3	Zu. 4	Ab. 1	Ab. 2	Ab. 3	Ab. 4	K-Sum
RAD	0	4	1	0	1	80	0	0	10	0	3	12	5	81	10	15	0	3	17	91	111
KRAD	0	0	0	0	0	3	0	0	6	0	8	0	0	3	6	8	0	8	0	9	17
PKW	23	16	7	0	7	504	0	32	135	0	985	56	46	511	167	1041	0	1040	79	646	1765
BUS	0	0	0	0	0	12	0	0	3	0	23	5	0	12	3	28	0	23	5	15	43
LFW	2	0	0	0	0	44	0	3	3	0	68	9	2	44	6	77	0	73	9	47	129
LKW	0	0	0	0	0	13	0	0	0	0	15	2	0	13	0	17	0	15	2	13	30
LZ	0	0	0	0	2	3	0	0	0	0	5	0	0	5	0	5	0	5	2	3	10
<b>KFZ</b>	<b>25</b>	<b>16</b>	<b>7</b>	<b>0</b>	<b>9</b>	<b>579</b>	<b>0</b>	<b>35</b>	<b>147</b>	<b>0</b>	<b>1104</b>	<b>72</b>	<b>48</b>	<b>588</b>	<b>182</b>	<b>1176</b>	<b>0</b>	<b>1164</b>	<b>97</b>	<b>733</b>	<b>1994</b>
SV	0	0	0	0	2	28	0	0	3	0	43	7	0	30	3	50	0	43	9	31	83
PV	23	16	7	0	7	519	0	32	144	0	1016	61	46	526	176	1077	0	1071	84	670	1825
GV	2	0	0	0	2	60	0	3	3	0	88	11	2	62	6	99	0	93	13	63	169
<b>FZ-ART</b>	<b>1-2</b>	<b>1-3</b>	<b>1-4</b>	<b>2-1</b>	<b>2-3</b>	<b>2-4</b>	<b>3-1</b>	<b>3-2</b>	<b>3-4</b>	<b>4-1</b>	<b>4-2</b>	<b>4-3</b>	<b>Zu. 1</b>	<b>Zu. 2</b>	<b>Zu. 3</b>	<b>Zu. 4</b>	<b>Ab. 1</b>	<b>Ab. 2</b>	<b>Ab. 3</b>	<b>Ab. 4</b>	<b>K-Sum</b>

**spezifische Spitzenstunde abends 16:45 Uhr - 17:45 Uhr**

FZ-ART	1-2	1-3	1-4	2-1	2-3	2-4	3-1	3-2	3-4	4-1	4-2	4-3	Zu. 1	Zu. 2	Zu. 3	Zu. 4	Ab. 1	Ab. 2	Ab. 3	Ab. 4	K-Sum
RAD	0	15	2	0	1	41	0	0	11	0	12	15	17	42	11	27	0	12	31	54	97
KRAD	0	2	3	0	0	21	0	0	6	0	14	5	5	21	6	19	0	14	7	30	51
PKW	17	31	33	0	9	1165	0	27	132	0	694	133	81	1174	159	827	0	738	173	1330	2241
BUS	0	0	0	0	0	3	0	0	3	0	10	2	0	3	3	12	0	10	2	6	18
LFW	1	0	3	0	0	45	0	0	4	0	30	3									

# Stadt Dachau

Zählstelle: K17 Münchener Straße / Goethestraße

Zusammenfassung Stundengruppen

Zähltag: Di., 24.04.2007

Zu-/Ablauf 1: Goethestr.

Zu-/Ablauf 2: Münchener Str. (von/nach Stadtauswärts)

Zu-/Ablauf 3: Hermann-Stockmann-Str.

Zu-/Ablauf 4: Münchener Str. (von/nach Stadteinwärts)

Spezifische Spitzenstunde morgens  
07:15 Uhr - 08:15 Uhr in KFZ

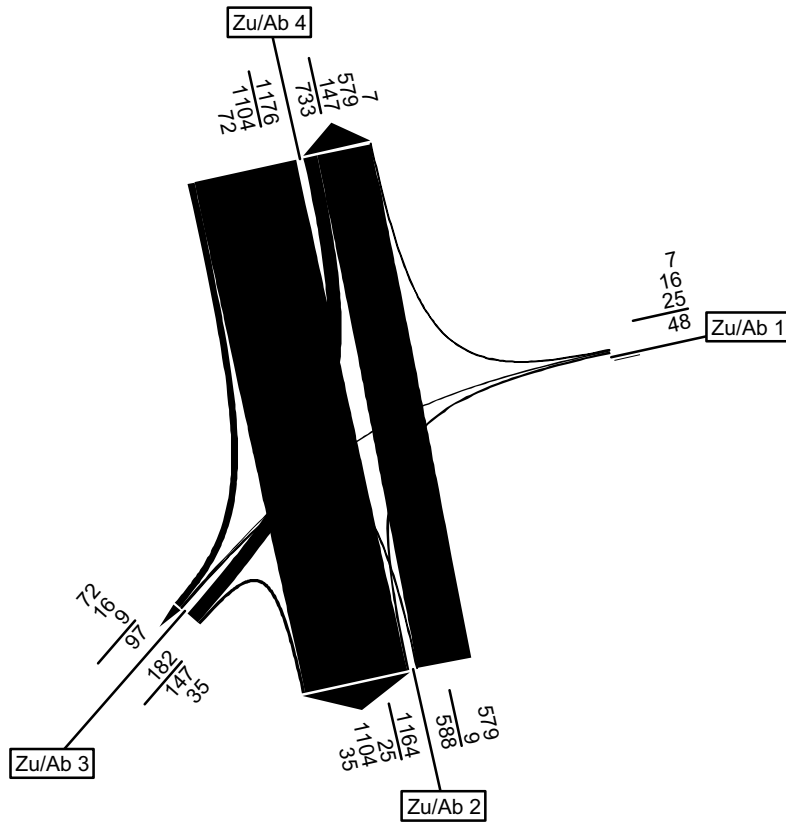

Spezifische Spitzenstunde abends  
16:45 Uhr - 17:45 Uhr in KFZ

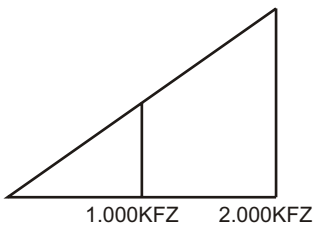
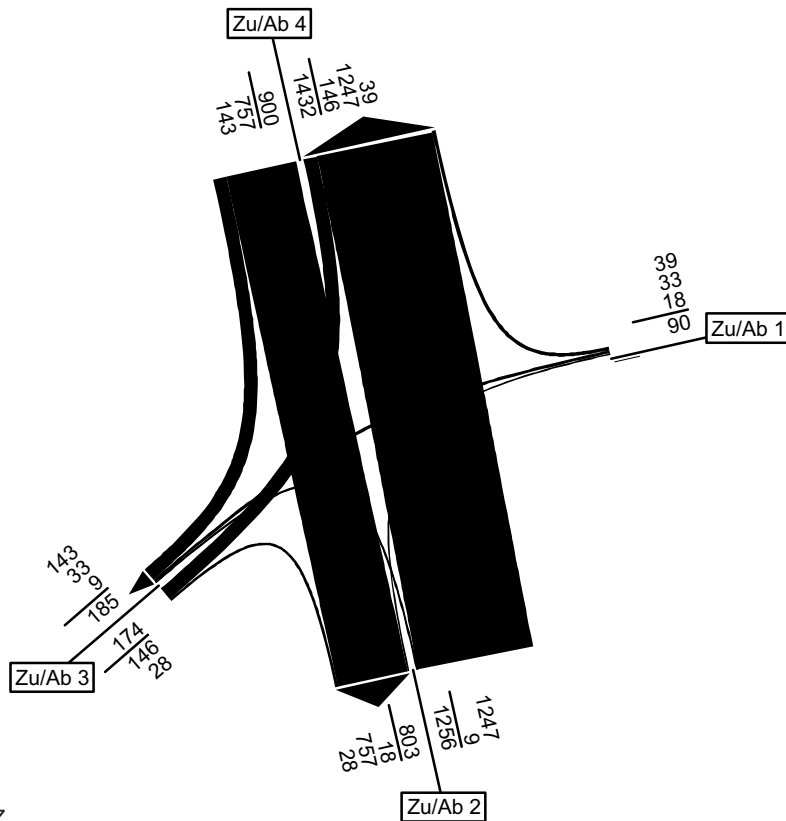

# Stadt Dachau

Zählstelle: K18 Münchener Straße / Bahnhofstraße

Zu-/Ablauf 1: Bahnhofstr.  
 Zu-/Ablauf 2: Münchener Str. (von/nach Stadttauswärts)  
 Zu-/Ablauf 3: Schillerstr.  
 Zu-/Ablauf 4: Münchener Str. (von/nach Stadteinwärts)

Zusammenfassung Stundengruppen

Zähltag: Di., 24.04.2007

Zählzeit: 06:00 Uhr - 10:00 Uhr und 15:00 Uhr - 19:00 Uhr

## Summe Zählzeit (06:00 Uhr - 10:00 Uhr und 15:00 Uhr - 19:00 Uhr)

FZ-ART	1-2	1-3	1-4	2-1	2-3	2-4	3-1	3-2	3-4	4-1	4-2	4-3	Zu. 1	Zu. 2	Zu. 3	Zu. 4	Ab. 1	Ab. 2	Ab. 3	Ab. 4	K-Sum
RAD	2	132	6	58	1	342	107	9	0	1	180	0	140	401	116	181	166	191	133	348	838
KRAD	8	35	13	16	24	74	36	28	0	9	67	4	56	114	64	80	61	103	63	87	314
PKW	1097	1167	445	1104	1960	3927	1512	2031	0	394	3542	530	2709	6991	3543	4466	3010	6670	3657	4372	17709
BUS	41	45	35	40	3	32	35	8	0	41	69	0	121	75	43	110	116	118	48	67	349
LFW	46	79	13	37	91	212	51	153	0	9	247	30	138	340	204	286	97	446	200	225	968
LKW	6	18	4	15	26	61	25	37	0	1	82	3	28	102	62	86	41	125	47	65	278
LZ	0	5	2	3	3	34	8	3	0	2	30	3	7	40	11	35	13	33	11	36	93
<b>KFZ</b>	<b>1198</b>	<b>1349</b>	<b>512</b>	<b>1215</b>	<b>2107</b>	<b>4340</b>	<b>1667</b>	<b>2260</b>	<b>0</b>	<b>456</b>	<b>4037</b>	<b>570</b>	<b>3059</b>	<b>7662</b>	<b>3927</b>	<b>5063</b>	<b>3338</b>	<b>7495</b>	<b>4026</b>	<b>4852</b>	<b>19711</b>
SV	47	68	41	58	32	127	68	48	0	44	181	6	156	217	116	231	170	276	106	168	720
PV	1146	1247	493	1160	1987	4033	1583	2067	0	444	3678	534	2886	7180	3650	4656	3187	6891	3768	4526	18372
GV	52	102	19	55	120	307	84	193	0	12	359	36	173	482	277	407	151	604	258	326	1339
<b>FZ-ART</b>	<b>1-2</b>	<b>1-3</b>	<b>1-4</b>	<b>2-1</b>	<b>2-3</b>	<b>2-4</b>	<b>3-1</b>	<b>3-2</b>	<b>3-4</b>	<b>4-1</b>	<b>4-2</b>	<b>4-3</b>	<b>Zu. 1</b>	<b>Zu. 2</b>	<b>Zu. 3</b>	<b>Zu. 4</b>	<b>Ab. 1</b>	<b>Ab. 2</b>	<b>Ab. 3</b>	<b>Ab. 4</b>	<b>K-Sum</b>

## Summe Zählintervall 06:00 Uhr - 10:00 Uhr

FZ-ART	1-2	1-3	1-4	2-1	2-3	2-4	3-1	3-2	3-4	4-1	4-2	4-3	Zu. 1	Zu. 2	Zu. 3	Zu. 4	Ab. 1	Ab. 2	Ab. 3	Ab. 4	K-Sum
RAD	0	44	1	27	0	190	84	6	0	0	38	0	45	217	90	38	111	44	44	191	390
KRAD	2	9	0	8	4	19	11	17	0	2	26	0	11	31	28	28	21	45	13	19	98
PKW	483	414	137	466	459	1302	570	1261	0	162	1949	171	1034	2227	1831	2282	1198	3693	1044	1439	7374
BUS	23	28	13	22	1	19	19	3	0	18	43	0	64	42	22	61	59	69	29	32	189
LFW	32	55	5	20	42	90	25	103	0	6	153	20	92	152	128	179	51	288	117	95	551
LKW	4	9	3	11	18	36	20	28	0	1	58	3	16	65	48	62	32	90	30	39	191
LZ	0	4	1	2	2	10	3	1	0	0	23	3	5	14	4	26	5	24	9	11	49
<b>KFZ</b>	<b>544</b>	<b>519</b>	<b>159</b>	<b>529</b>	<b>526</b>	<b>1476</b>	<b>648</b>	<b>1413</b>	<b>0</b>	<b>189</b>	<b>2252</b>	<b>197</b>	<b>1222</b>	<b>2531</b>	<b>2061</b>	<b>2638</b>	<b>1366</b>	<b>4209</b>	<b>1242</b>	<b>1635</b>	<b>8452</b>
SV	27	41	17	35	21	65	42	32	0	19	124	6	85	121	74	149	96	183	68	82	429
PV	508	451	150	496	464	1340	600	1281	0	182	2018	171	1109	2300	1881	2371	1278	3807	1086	1490	7661
GV	36	68	9	33	62	136	48	132	0	7	234	26	113	231	180	267	88	402	156	145	791
<b>FZ-ART</b>	<b>1-2</b>	<b>1-3</b>	<b>1-4</b>	<b>2-1</b>	<b>2-3</b>	<b>2-4</b>	<b>3-1</b>	<b>3-2</b>	<b>3-4</b>	<b>4-1</b>	<b>4-2</b>	<b>4-3</b>	<b>Zu. 1</b>	<b>Zu. 2</b>	<b>Zu. 3</b>	<b>Zu. 4</b>	<b>Ab. 1</b>	<b>Ab. 2</b>	<b>Ab. 3</b>	<b>Ab. 4</b>	<b>K-Sum</b>

## Summe Zählintervall 15:00 Uhr - 19:00 Uhr

FZ-ART	1-2	1-3	1-4	2-1	2-3	2-4	3-1	3-2	3-4	4-1	4-2	4-3	Zu. 1	Zu. 2	Zu. 3	Zu. 4	Ab. 1	Ab. 2	Ab. 3	Ab. 4	K-Sum
RAD	2	88	5	31	1	152	23	3	0	1	142	0	95	184	26	143	55	147	89	157	448
KRAD	6	26	13	8	20	55	25	11	0	7	41	4	45	83	36	52	40	58	50	68	216
PKW	614	753	308	638	1501	2625	942	770	0	232	1593	359	1675	4764	1712	2184	1812	2977	2613	2933	10335
BUS	18	17	22	18	2	13	16	5	0	23	26	0	57	33	21	49	57	49	19	35	160
LFW	14	24	8	17	49	122	26	50	0	3	94	10	46	188	76	107	46	158	83	130	417
LKW	2	9	1	4	8	25	5	9	0	0	24	0	12	37	14	24	9	35	17	26	87
LZ	0	1	1	1	1	24	5	2	0	2	7	0	2	26	7	9	8	9	2	25	44
<b>KFZ</b>	<b>654</b>	<b>830</b>	<b>353</b>	<b>686</b>	<b>1581</b>	<b>2864</b>	<b>1019</b>	<b>847</b>	<b>0</b>	<b>267</b>	<b>1785</b>	<b>373</b>	<b>1837</b>	<b>5131</b>	<b>1866</b>	<b>2425</b>	<b>1972</b>	<b>3286</b>	<b>2784</b>	<b>3217</b>	<b>11259</b>
SV	20	27	24	23	11	62	26	16	0	25	57	0	71	96	42	82	74	93	38	86	291
PV	638	796	343	664	1523	2693	983	786	0	262	1660	363	1777	4880	1769	2285	1909	3084	2682	3036	10711
GV	16	34	10	22	58	171	36	61	0	5	125	10	60	251	97	140	63	202	102	181	548
<b>FZ-ART</b>	<b>1-2</b>	<b>1-3</b>	<b>1-4</b>	<b>2-1</b>	<b>2-3</b>	<b>2-4</b>	<b>3-1</b>	<b>3-2</b>	<b>3-4</b>	<b>4-1</b>	<b>4-2</b>	<b>4-3</b>	<b>Zu. 1</b>	<b>Zu. 2</b>	<b>Zu. 3</b>	<b>Zu. 4</b>	<b>Ab. 1</b>	<b>Ab. 2</b>	<b>Ab. 3</b>	<b>Ab. 4</b>	<b>K-Sum</b>

## spezifische Spitzenstunde morgens 07:15 Uhr - 08:15 Uhr

FZ-ART	1-2	1-3	1-4	2-1	2-3	2-4	3-1	3-2	3-4	4-1	4-2	4-3	Zu. 1	Zu. 2	Zu. 3	Zu. 4	Ab. 1	Ab. 2	Ab. 3	Ab. 4	K-Sum
RAD	0	14	0	4	0	87	68	1	0	0	14	0	14	91	69	14	72	15	14	87	188
KRAD	0	5	0	4	1	4	5	3	0	0	5	0	5	9	8	5	9	8	6	4	27
PKW	120	134	22	116	160	370	185	323	0	42	598	50	276	646	508	690	343	1041	344	392	2120
BUS	7	12	5	9	1	5	6	1	0	7	20	0	24	15	7	27	22	28	13	10	73
LFW	7	24	2	8	17	22	8	31	0	3	39	7	33	47	39	49	19	77	48	24	168
LKW	2	4	2	3	6	4	6	9	0	1	6	1	8	13	15	8	10	17	11	6	44
LZ	0	3	0	1	0	2	0	0	0	0	5	0	3	3	0	5	1	5	3	2	11
<b>KFZ</b>	<b>136</b>	<b>182</b>	<b>31</b>	<b>141</b>	<b>185</b>	<b>407</b>	<b>210</b>	<b>367</b>	<b>0</b>	<b>53</b>	<b>673</b>	<b>58</b>	<b>349</b>	<b>733</b>	<b>577</b>	<b>784</b>	<b>404</b>	<b>1176</b>	<b>425</b>	<b>438</b>	<b>2443</b>
SV	9	19	7	13	7	11	12	10	0	8	31	1	35	31	22	40	33	50	27	18	128
PV	127	151	27	129	162	379	196	327	0	49	623	50	305	670	523	722	374	1077	363	406	2220
GV	9	31	4	12	23	28	14	40	0	4	50	8	44	63	54	62	30	99	62	32	223
<b>FZ-ART</b>	<b>1-2</b>	<b>1-3</b>	<b>1-4</b>	<b>2-1</b>	<b>2-3</b>	<b>2-4</b>	<b>3-1</b>	<b>3-2</b>	<b>3-4</b>	<b>4-1</b>	<b>4-2</b>	<b>4-3</b>	<b>Zu. 1</b>	<b>Zu. 2</b>	<b>Zu. 3</b>	<b>Zu. 4</b>	<b>Ab. 1</b>	<b>Ab. 2</b>	<b>Ab. 3</b>	<b>Ab. 4</b>	<b>K-Sum</b>

## spezifische Spitzenstunde abends 17:00 Uhr - 18:00 Uhr

FZ-ART	1-2	1-3	1-4	2-1	2-3	2-4	3-1	3-2	3-4	4-1	4-2	4-3	Zu. 1	Zu. 2	Zu. 3	Zu. 4	Ab. 1	Ab. 2	Ab. 3	Ab. 4	K-Sum
RAD	0	30	1	9	1	41	8	0	0	0	36	0	31	51	8	36	17	36	31	42	126
KRAD	1	4	4	5	6	24	12	3	0	5	14	1	9	35	15	20	22	18	11	28	79
PKW	170	221	76	165	411	722	310	208	0	67	446	90	467	1298	518	603	542	824	722	798	2886
BUS</																					

# Stadt Dachau

Zählstelle: K18 Münchener Straße / Bahnhofstraße

Zusammenfassung Stundengruppen

Zähltag: Di., 24.04.2007

Zu-/Ablauf 1: Bahnhofstr.  
 Zu-/Ablauf 2: Münchener Str. (von/nach Stadtauswärts)  
 Zu-/Ablauf 3: Schillerstr.  
 Zu-/Ablauf 4: Münchener Str. (von/nach Stadteinwärts)

Spezifische Spitzenstunde morgens  
 07:15 Uhr - 08:15 Uhr in KFZ

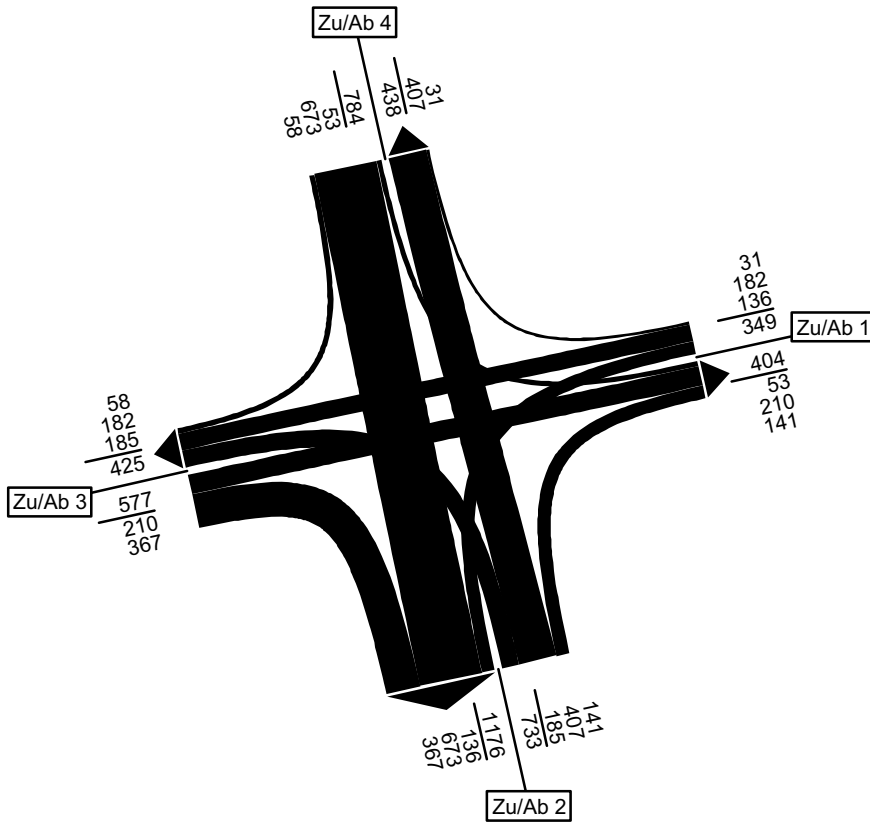

Spezifische Spitzenstunde abends  
 17:00 Uhr - 18:00 Uhr in KFZ

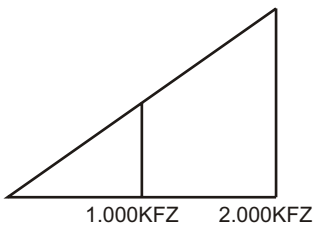
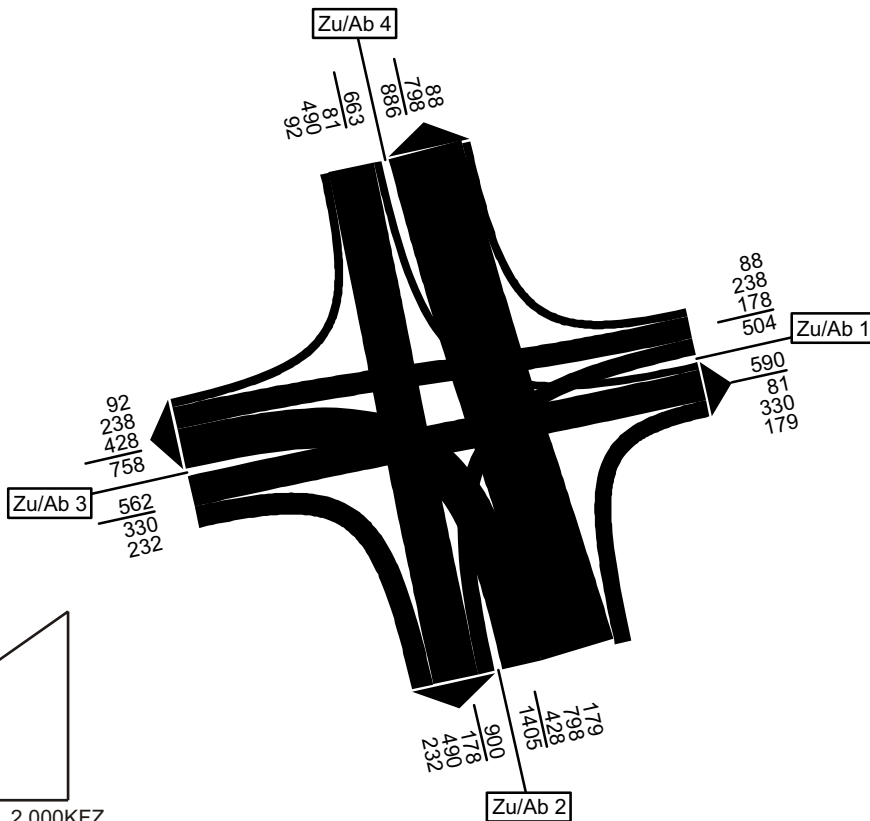

**Stadt Dachau**

Zählstelle: K19 Münchener Straße / Gröbenreider Straße

Zu-/Ablauf 1: Münchener Str. (von/nach Stadtauswärts)

Zu-/Ablauf 2: Gröbenreider Str.

Zu-/Ablauf 3: Münchener Str. (von/nach Stadteinwärts)

Zusammenfassung Stundengruppen

Zähltag: Di., 24.04.2007

Zählzeit: 06:00 Uhr - 10:00 Uhr und 15:00 Uhr - 19:00 Uhr

**Summe Zähizeit (06:00 Uhr - 10:00 Uhr und 15:00 Uhr - 19:00 Uhr)**

FZ-ART	1-2	1-3	1-4	2-1	2-3	2-4	3-1	3-2	3-4	4-1	4-2	4-3	Zu. 1	Zu. 2	Zu. 3	Zu. 4	Ab. 1	Ab. 2	Ab. 3	Ab. 4	K-Sum
RAD	6	330	0	0	51	0	182	66	0	0	0	0	336	51	248	0	182	72	381	0	635
KRAD	5	96	0	3	12	0	88	20	0	0	0	0	101	15	108	0	91	25	108	0	224
PKW	261	4087	0	366	816	0	4077	753	0	0	0	0	4348	1182	4830	0	4443	1014	4903	0	10360
BUS	1	66	0	0	2	0	110	0	0	0	0	0	67	2	110	0	110	1	68	0	179
LFW	11	214	0	1	24	0	286	39	0	0	0	0	225	25	325	0	287	50	238	0	575
LKW	1	64	0	0	8	0	86	6	0	0	0	0	65	8	92	0	86	7	72	0	165
LZ	0	36	0	0	1	0	36	0	0	0	0	0	36	1	36	0	36	0	37	0	73
<b>KFZ</b>	<b>279</b>	<b>4563</b>	<b>0</b>	<b>370</b>	<b>863</b>	<b>0</b>	<b>4683</b>	<b>818</b>	<b>0</b>	<b>0</b>	<b>0</b>	<b>0</b>	<b>4842</b>	<b>1233</b>	<b>5501</b>	<b>0</b>	<b>5053</b>	<b>1097</b>	<b>5426</b>	<b>0</b>	<b>11576</b>
SV	2	166	0	0	11	0	232	6	0	0	0	0	168	11	238	0	232	8	177	0	417
PV	267	4249	0	369	830	0	4275	773	0	0	0	0	4516	1199	5048	0	4644	1040	5079	0	10763
GV	12	314	0	1	33	0	408	45	0	0	0	0	326	34	453	0	409	57	347	0	813
<b>FZ-ART</b>	<b>1-2</b>	<b>1-3</b>	<b>1-4</b>	<b>2-1</b>	<b>2-3</b>	<b>2-4</b>	<b>3-1</b>	<b>3-2</b>	<b>3-4</b>	<b>4-1</b>	<b>4-2</b>	<b>4-3</b>	<b>Zu. 1</b>	<b>Zu. 2</b>	<b>Zu. 3</b>	<b>Zu. 4</b>	<b>Ab. 1</b>	<b>Ab. 2</b>	<b>Ab. 3</b>	<b>Ab. 4</b>	<b>K-Sum</b>

**Summe Zählintervall 06:00 Uhr - 10:00 Uhr**

FZ-ART	1-2	1-3	1-4	2-1	2-3	2-4	3-1	3-2	3-4	4-1	4-2	4-3	Zu. 1	Zu. 2	Zu. 3	Zu. 4	Ab. 1	Ab. 2	Ab. 3	Ab. 4	K-Sum
RAD	2	187	0	0	29	0	39	4	0	0	0	0	189	29	43	0	39	6	216	0	261
KRAD	0	21	0	3	3	0	29	2	0	0	0	0	21	6	31	0	32	2	24	0	58
PKW	67	1361	0	202	410	0	2068	226	0	0	0	0	1428	612	2294	0	2270	293	1771	0	4334
BUS	0	32	0	0	1	0	61	0	0	0	0	0	32	1	61	0	61	0	33	0	94
LFW	5	90	0	1	17	0	179	19	0	0	0	0	95	18	198	0	180	24	107	0	311
LKW	1	38	0	0	3	0	62	1	0	0	0	0	39	3	63	0	62	2	41	0	105
LZ	0	11	0	0	0	0	26	0	0	0	0	0	11	0	26	0	26	0	11	0	37
<b>KFZ</b>	<b>73</b>	<b>1553</b>	<b>0</b>	<b>206</b>	<b>434</b>	<b>0</b>	<b>2425</b>	<b>248</b>	<b>0</b>	<b>0</b>	<b>0</b>	<b>0</b>	<b>1626</b>	<b>640</b>	<b>2673</b>	<b>0</b>	<b>2631</b>	<b>321</b>	<b>1987</b>	<b>0</b>	<b>4939</b>
SV	1	81	0	0	4	0	149	1	0	0	0	0	82	4	150	0	149	2	85	0	236
PV	67	1414	0	205	414	0	2158	228	0	0	0	0	1481	619	2386	0	2363	295	1828	0	4486
GV	6	139	0	1	20	0	267	20	0	0	0	0	145	21	287	0	268	26	159	0	453
<b>FZ-ART</b>	<b>1-2</b>	<b>1-3</b>	<b>1-4</b>	<b>2-1</b>	<b>2-3</b>	<b>2-4</b>	<b>3-1</b>	<b>3-2</b>	<b>3-4</b>	<b>4-1</b>	<b>4-2</b>	<b>4-3</b>	<b>Zu. 1</b>	<b>Zu. 2</b>	<b>Zu. 3</b>	<b>Zu. 4</b>	<b>Ab. 1</b>	<b>Ab. 2</b>	<b>Ab. 3</b>	<b>Ab. 4</b>	<b>K-Sum</b>

**Summe Zählintervall 15:00 Uhr - 19:00 Uhr**

FZ-ART	1-2	1-3	1-4	2-1	2-3	2-4	3-1	3-2	3-4	4-1	4-2	4-3	Zu. 1	Zu. 2	Zu. 3	Zu. 4	Ab. 1	Ab. 2	Ab. 3	Ab. 4	K-Sum
RAD	4	143	0	0	22	0	143	62	0	0	0	0	147	22	205	0	143	66	165	0	374
KRAD	5	75	0	0	9	0	59	18	0	0	0	0	80	9	77	0	59	23	84	0	166
PKW	194	2726	0	164	406	0	2009	527	0	0	0	0	2920	570	2536	0	2173	721	3132	0	6026
BUS	1	34	0	0	1	0	49	0	0	0	0	0	35	1	49	0	49	1	35	0	85
LFW	6	124	0	0	7	0	107	20	0	0	0	0	130	7	127	0	107	26	131	0	284
LKW	0	26	0	0	5	0	24	5	0	0	0	0	26	5	29	0	24	5	31	0	60
LZ	0	25	0	0	1	0	10	0	0	0	0	0	25	1	10	0	25	0	26	0	36
<b>KFZ</b>	<b>206</b>	<b>3010</b>	<b>0</b>	<b>164</b>	<b>429</b>	<b>0</b>	<b>2258</b>	<b>570</b>	<b>0</b>	<b>0</b>	<b>0</b>	<b>0</b>	<b>3216</b>	<b>593</b>	<b>2828</b>	<b>0</b>	<b>2422</b>	<b>776</b>	<b>3439</b>	<b>0</b>	<b>6637</b>
SV	1	85	0	0	7	0	83	5	0	0	0	0	86	7	88	0	83	6	92	0	181
PV	200	2835	0	164	416	0	2117	545	0	0	0	0	3035	580	2662	0	2281	745	3251	0	6277
GV	6	175	0	0	13	0	141	25	0	0	0	0	181	13	166	0	141	31	188	0	360
<b>FZ-ART</b>	<b>1-2</b>	<b>1-3</b>	<b>1-4</b>	<b>2-1</b>	<b>2-3</b>	<b>2-4</b>	<b>3-1</b>	<b>3-2</b>	<b>3-4</b>	<b>4-1</b>	<b>4-2</b>	<b>4-3</b>	<b>Zu. 1</b>	<b>Zu. 2</b>	<b>Zu. 3</b>	<b>Zu. 4</b>	<b>Ab. 1</b>	<b>Ab. 2</b>	<b>Ab. 3</b>	<b>Ab. 4</b>	<b>K-Sum</b>

**spezifische Spitzenstunde morgens 07:30 Uhr - 08:30 Uhr**

FZ-ART	1-2	1-3	1-4	2-1	2-3	2-4	3-1	3-2	3-4	4-1	4-2	4-3	Zu. 1	Zu. 2	Zu. 3	Zu. 4	Ab. 1	Ab. 2	Ab. 3	Ab. 4	K-Sum
RAD	0	83	0	0	10	0	5	1	0	0	0	0	83	10	6	0	5	1	93	0	99
KRAD	0	4	0	0	3	0	5	0	0	0	0	0	4	3	5	0	5	0	7	0	12
PKW	25	379	0	96	157	0	589	83	0	0	0	0	404	253	672	0	685	108	536	0	1329
BUS	0	8	0	0	1	0	24	0	0	0	0	0	8	1	24	0	24	0	9	0	33
LFW	0	28	0	0	5	0	48	5	0	0	0	0	28	5	53	0	48	5	33	0	86
LKW	0	6	0	0	1	0	12	1	0	0	0	0	6	1	13	0	12	1	7	0	20
LZ	0	1	0	0	0	0	6	0	0	0	0	0	1	0	6	0	6	0	1	0	7
<b>KFZ</b>	<b>25</b>	<b>426</b>	<b>0</b>	<b>96</b>	<b>167</b>	<b>0</b>	<b>684</b>	<b>89</b>	<b>0</b>	<b>0</b>	<b>0</b>	<b>0</b>	<b>451</b>	<b>263</b>	<b>773</b>	<b>0</b>	<b>780</b>	<b>114</b>	<b>593</b>	<b>0</b>	<b>1487</b>
SV	0	15	0	0	2	0	42	1	0	0	0	0	15	2	43	0	42	1	17	0	60
PV	25	391	0	96	161	0	618	83	0	0	0	0	416	257	701	0	714	108	552	0	1374
GV	0	35	0	0	6	0	66	6	0	0	0	0	35	6	72	0	66	6	41	0	113
<b>FZ-ART</b>	<b>1-2</b>	<b>1-3</b>	<b>1-4</b>	<b>2-1</b>	<b>2-3</b>	<b>2-4</b>	<b>3-1</b>	<b>3-2</b>	<b>3-4</b>	<b>4-1</b>	<b>4-2</b>	<b>4-3</b>	<b>Zu. 1</b>	<b>Zu. 2</b>	<b>Zu. 3</b>	<b>Zu. 4</b>	<b>Ab. 1</b>	<b>Ab. 2</b>	<b>Ab. 3</b>	<b>Ab. 4</b>	<b>K-Sum</b>

**spezifische Spitzenstunde abends 16:45 Uhr - 17:45 Uhr**

FZ-ART	1-2	1-3	1-4	2-1	2-3	2-4	3-1	3-2	3-4	4-1	4-2	4-3	Zu. 1	Zu. 2	Zu. 3	Zu. 4	Ab. 1	Ab. 2	Ab. 3	Ab. 4	K-Sum
RAD	0	38	0	0	2	0	26	9	0	0	0	0	38	2	35	0	26	9	40	0	75
KRAD	4	22	0	0	2	0	23	5	0	0	0	0	26	2	28	0	23	9	24	0	56
PKW	65	789	0	38	128	0	580	182	0	0	0	0	854	166	762	0	618	247	917	0	1782
BUS	1	6	0	0	0	0	13	0	0	0	0	0	7	0	13	0	13	1	6	0	20
LFW	2	36	0	0	1	0	19	6	0	0	0	0	38	1	25	0	19	8	37	0	64
LKW	0	8	0	0	2	0	7	1	0	0	0	0	8								

# Stadt Dachau

Zählstelle: K19 Münchener Straße / Gröbenrieder Straße

Zusammenfassung Stundengruppen

Zähltag: Di., 24.04.2007

Zu-/Ablauf 1: Münchener Str. (von/nach Stadtauswärts)

Zu-/Ablauf 2: Gröbenrieder Str.

Zu-/Ablauf 3: Münchener Str. (von/nach Stadteinwärts)

Spezifische Spitzenstunde morgens  
07:30 Uhr - 08:30 Uhr in KFZ

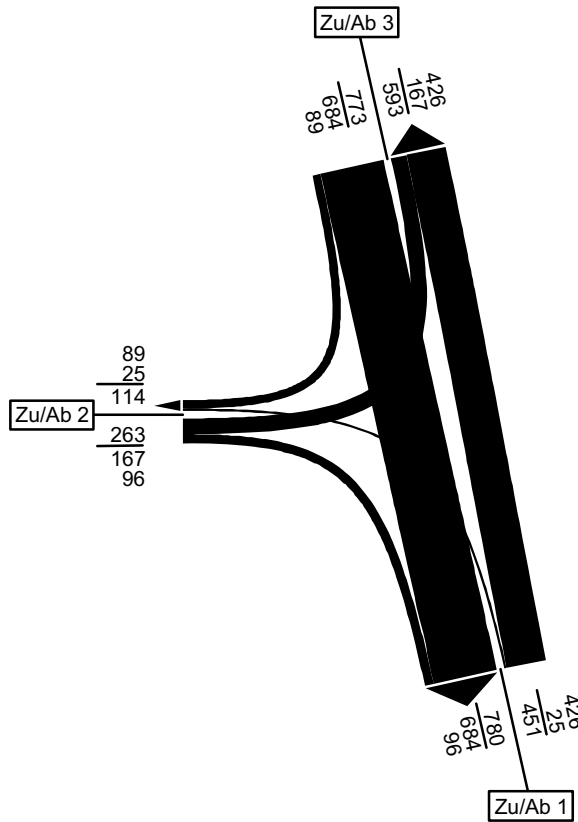

Spezifische Spitzenstunde abends  
16:45 Uhr - 17:45 Uhr in KFZ

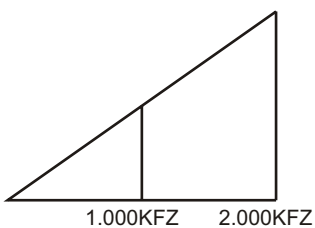
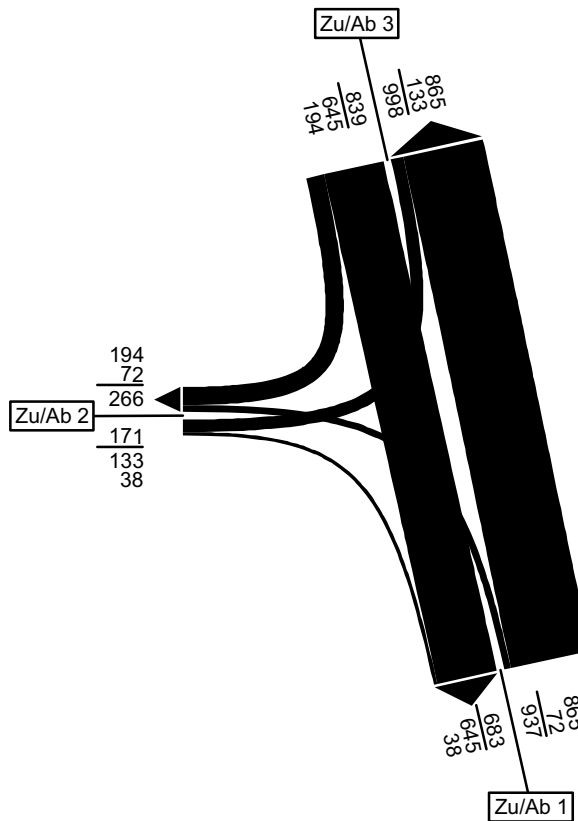

# Stadt Dachau

Zählstelle: K20 Münchener Straße / Schleißheimer Straße

Zu-/Ablauf 1: Schleißheimer Str.  
 Zu-/Ablauf 2: Münchener Str. (von/nach Stadttauswärts)  
 Zu-/Ablauf 3: Ludwig-Dill-Str.  
 Zu-/Ablauf 4: Münchener Str. (von/nach Amperbrücke)

Zusammenfassung Stundengruppen

Zähltag: Di., 24.04.2007

Zählzeit: 06:00 Uhr - 10:00 Uhr und 15:00 Uhr - 19:00 Uhr

## Summe Zählzeit (06:00 Uhr - 10:00 Uhr und 15:00 Uhr - 19:00 Uhr)

FZ-ART	1-2	1-3	1-4	2-1	2-3	2-4	3-1	3-2	3-4	4-1	4-2	4-3	Zu. 1	Zu. 2	Zu. 3	Zu. 4	Ab. 1	Ab. 2	Ab. 3	Ab. 4	K-Sum
RAD	11	0	83	64	0	317	67	7	22	56	230	0	94	381	96	286	187	248	0	422	857
KRAD	18	0	14	14	0	94	13	1	3	8	89	0	32	108	17	97	35	108	0	111	254
PKW	1128	0	378	1210	0	3693	117	49	17	510	3653	0	1506	4903	183	4163	1837	4830	0	4088	10755
BUS	3	0	2	0	0	68	1	0	0	7	107	0	5	68	1	114	8	110	0	70	188
LFW	51	0	24	64	0	174	2	1	5	25	273	0	75	238	8	298	91	325	0	203	619
LKW	10	0	3	10	0	62	1	0	1	6	82	0	13	72	2	88	17	92	0	66	175
LZ	1	0	0	1	0	36	0	0	0	0	35	0	1	37	0	35	1	36	0	36	73
<b>KFZ</b>	<b>1211</b>	<b>0</b>	<b>421</b>	<b>1299</b>	<b>0</b>	<b>4127</b>	<b>134</b>	<b>51</b>	<b>26</b>	<b>556</b>	<b>4239</b>	<b>0</b>	<b>1632</b>	<b>5426</b>	<b>211</b>	<b>4795</b>	<b>1989</b>	<b>5501</b>	<b>0</b>	<b>4574</b>	<b>12064</b>
SV	14	0	5	11	0	166	2	0	1	13	224	0	19	177	3	237	26	238	0	172	436
PV	1149	0	394	1224	0	3855	131	50	20	525	3849	0	1543	5079	201	4374	1880	5048	0	4269	11197
GV	62	0	27	75	0	272	3	1	6	31	390	0	89	347	10	421	109	453	0	305	867
<b>FZ-ART</b>	<b>1-2</b>	<b>1-3</b>	<b>1-4</b>	<b>2-1</b>	<b>2-3</b>	<b>2-4</b>	<b>3-1</b>	<b>3-2</b>	<b>3-4</b>	<b>4-1</b>	<b>4-2</b>	<b>4-3</b>	<b>Zu. 1</b>	<b>Zu. 2</b>	<b>Zu. 3</b>	<b>Zu. 4</b>	<b>Ab. 1</b>	<b>Ab. 2</b>	<b>Ab. 3</b>	<b>Ab. 4</b>	<b>K-Sum</b>

## Summe Zählintervall 06:00 Uhr - 10:00 Uhr

FZ-ART	1-2	1-3	1-4	2-1	2-3	2-4	3-1	3-2	3-4	4-1	4-2	4-3	Zu. 1	Zu. 2	Zu. 3	Zu. 4	Ab. 1	Ab. 2	Ab. 3	Ab. 4	K-Sum
RAD	2	0	20	21	0	195	36	3	12	29	38	0	22	216	51	67	86	43	0	227	356
KRAD	3	0	0	2	0	22	7	0	1	0	28	0	3	24	8	28	9	31	0	23	63
PKW	377	0	140	482	0	1289	77	36	11	243	1881	0	517	1771	124	2124	802	2294	0	1440	4536
BUS	1	0	2	0	0	33	0	0	0	1	60	0	3	33	0	61	1	61	0	35	97
LFW	34	0	8	40	0	67	1	1	4	14	163	0	42	107	6	177	55	198	0	79	332
LKW	7	0	0	7	0	34	1	0	1	5	56	0	7	41	2	61	13	63	0	35	111
LZ	1	0	0	1	0	10	0	0	0	0	25	0	1	11	0	25	1	26	0	10	37
<b>KFZ</b>	<b>423</b>	<b>0</b>	<b>150</b>	<b>532</b>	<b>0</b>	<b>1455</b>	<b>86</b>	<b>37</b>	<b>17</b>	<b>263</b>	<b>2213</b>	<b>0</b>	<b>573</b>	<b>1987</b>	<b>140</b>	<b>2476</b>	<b>881</b>	<b>2673</b>	<b>0</b>	<b>1622</b>	<b>5176</b>
SV	9	0	2	8	0	77	1	0	1	6	141	0	11	85	2	147	15	150	0	80	245
PV	381	0	142	484	0	1344	84	36	12	244	1969	0	523	1828	132	2213	812	2386	0	1498	4686
GV	42	0	8	48	0	111	2	1	5	19	244	0	50	159	8	263	69	287	0	124	480
<b>FZ-ART</b>	<b>1-2</b>	<b>1-3</b>	<b>1-4</b>	<b>2-1</b>	<b>2-3</b>	<b>2-4</b>	<b>3-1</b>	<b>3-2</b>	<b>3-4</b>	<b>4-1</b>	<b>4-2</b>	<b>4-3</b>	<b>Zu. 1</b>	<b>Zu. 2</b>	<b>Zu. 3</b>	<b>Zu. 4</b>	<b>Ab. 1</b>	<b>Ab. 2</b>	<b>Ab. 3</b>	<b>Ab. 4</b>	<b>K-Sum</b>

## Summe Zählintervall 15:00 Uhr - 19:00 Uhr

FZ-ART	1-2	1-3	1-4	2-1	2-3	2-4	3-1	3-2	3-4	4-1	4-2	4-3	Zu. 1	Zu. 2	Zu. 3	Zu. 4	Ab. 1	Ab. 2	Ab. 3	Ab. 4	K-Sum
RAD	9	0	63	43	0	122	31	4	10	27	192	0	72	165	45	219	101	205	0	195	501
KRAD	15	0	14	12	0	72	6	1	2	8	61	0	29	84	9	69	26	77	0	88	191
PKW	751	0	238	728	0	2404	40	13	6	267	1772	0	989	3132	59	2039	1035	2536	0	2648	6219
BUS	2	0	0	0	0	35	1	0	0	6	47	0	2	35	1	53	7	49	0	35	91
LFW	17	0	16	24	0	107	1	0	1	11	110	0	33	131	2	121	36	127	0	124	287
LKW	3	0	3	3	0	28	0	0	0	1	26	0	6	31	0	27	4	29	0	31	64
LZ	0	0	0	0	0	26	0	0	0	0	10	0	0	26	0	10	0	10	0	26	36
<b>KFZ</b>	<b>788</b>	<b>0</b>	<b>271</b>	<b>767</b>	<b>0</b>	<b>2672</b>	<b>48</b>	<b>14</b>	<b>9</b>	<b>293</b>	<b>2026</b>	<b>0</b>	<b>1059</b>	<b>3439</b>	<b>71</b>	<b>2319</b>	<b>1108</b>	<b>2828</b>	<b>0</b>	<b>2952</b>	<b>6888</b>
SV	5	0	3	3	0	89	1	0	0	7	83	0	8	92	1	90	11	88	0	92	191
PV	768	0	252	740	0	2511	47	14	8	281	1880	0	1020	3251	69	2161	1068	2662	0	2771	6501
GV	20	0	19	27	0	161	1	0	1	12	146	0	39	188	2	158	40	166	0	181	387
<b>FZ-ART</b>	<b>1-2</b>	<b>1-3</b>	<b>1-4</b>	<b>2-1</b>	<b>2-3</b>	<b>2-4</b>	<b>3-1</b>	<b>3-2</b>	<b>3-4</b>	<b>4-1</b>	<b>4-2</b>	<b>4-3</b>	<b>Zu. 1</b>	<b>Zu. 2</b>	<b>Zu. 3</b>	<b>Zu. 4</b>	<b>Ab. 1</b>	<b>Ab. 2</b>	<b>Ab. 3</b>	<b>Ab. 4</b>	<b>K-Sum</b>

## spezifische Spitzenstunde morgens 07:30 Uhr - 08:30 Uhr

FZ-ART	1-2	1-3	1-4	2-1	2-3	2-4	3-1	3-2	3-4	4-1	4-2	4-3	Zu. 1	Zu. 2	Zu. 3	Zu. 4	Ab. 1	Ab. 2	Ab. 3	Ab. 4	K-Sum
RAD	1	0	7	9	0	84	28	0	7	21	5	0	8	93	35	26	58	6	0	98	162
KRAD	0	0	0	2	0	5	7	0	1	0	5	0	0	7	8	5	9	5	0	6	20
PKW	128	0	42	166	0	370	46	24	5	74	520	0	170	536	75	594	286	672	0	417	1375
BUS	0	0	0	0	0	9	0	0	0	0	24	0	0	9	0	24	0	24	0	9	33
LFW	11	0	4	16	0	17	0	0	0	2	42	0	15	33	0	44	18	53	0	21	92
LKW	1	0	0	2	0	5	1	0	0	3	12	0	1	7	1	15	6	13	0	5	24
LZ	0	0	0	0	0	1	0	0	0	0	6	0	0	1	0	6	0	6	0	1	7
<b>KFZ</b>	<b>140</b>	<b>0</b>	<b>46</b>	<b>186</b>	<b>0</b>	<b>407</b>	<b>54</b>	<b>24</b>	<b>6</b>	<b>79</b>	<b>609</b>	<b>0</b>	<b>186</b>	<b>593</b>	<b>84</b>	<b>688</b>	<b>319</b>	<b>773</b>	<b>0</b>	<b>459</b>	<b>1551</b>
SV	1	0	0	2	0	15	1	0	0	3	42	0	1	17	1	45	6	43	0	15	64
PV	128	0	42	168	0	384	53	24	6	74	549	0	170	552	83	623	295	701	0	432	1428
GV	12	0	4	18	0	23	1	0	0	5	60	0	16	41	1	65	24	72	0	27	123
<b>FZ-ART</b>	<b>1-2</b>	<b>1-3</b>	<b>1-4</b>	<b>2-1</b>	<b>2-3</b>	<b>2-4</b>	<b>3-1</b>	<b>3-2</b>	<b>3-4</b>	<b>4-1</b>	<b>4-2</b>	<b>4-3</b>	<b>Zu. 1</b>	<b>Zu. 2</b>	<b>Zu. 3</b>	<b>Zu. 4</b>	<b>Ab. 1</b>	<b>Ab. 2</b>	<b>Ab. 3</b>	<b>Ab. 4</b>	<b>K-Sum</b>

## spezifische Spitzenstunde abends 16:45 Uhr - 17:45 Uhr

FZ-ART	1-2	1-3	1-4	2-1	2-3	2-4	3-1	3-2	3-4	4-1	4-2	4-3	Zu. 1	Zu. 2	Zu. 3	Zu. 4	Ab. 1	Ab. 2	Ab. 3	Ab. 4	K-Sum
RAD	2	0	18	8	0	32	9	2	3	1	31	0	20	40	14	32	18	35	0	53	106
KRAD	2	0	2	3	0	21	1	1	2	25	0	0	4	24	3	27	6	28	0	24	58
PKW	221	0	48	226	0	691	8	5	2	80	536	0	269	917	15	616	314	762	0	741	1817
BUS	0	0	0	0	0	6	1	0	0	2	13	0	0	6	1	15	3	13	0	6	22
LFW	3	0	3	6	0	31	1	0	0	1	22	0	6	37	1	23	8	25	0	34	67
LKW	2	0	1																		



# Stadt Dachau

Zählstelle: K20 Münchener Straße / Schleißheimer Straße

Zusammenfassung Stundengruppen

Zähltag: Di., 24.04.2007

- Zu-/Ablauf 1: Schleißheimer Str.
- Zu-/Ablauf 2: Münchener Str. (von/nach Stadtauswärts)
- Zu-/Ablauf 3: Ludwig-Dill-Str.
- Zu-/Ablauf 4: Münchener Str. (von/nach Amperbrücke)

Spezifische Spitzenstunde morgens  
07:30 Uhr - 08:30 Uhr in KFZ

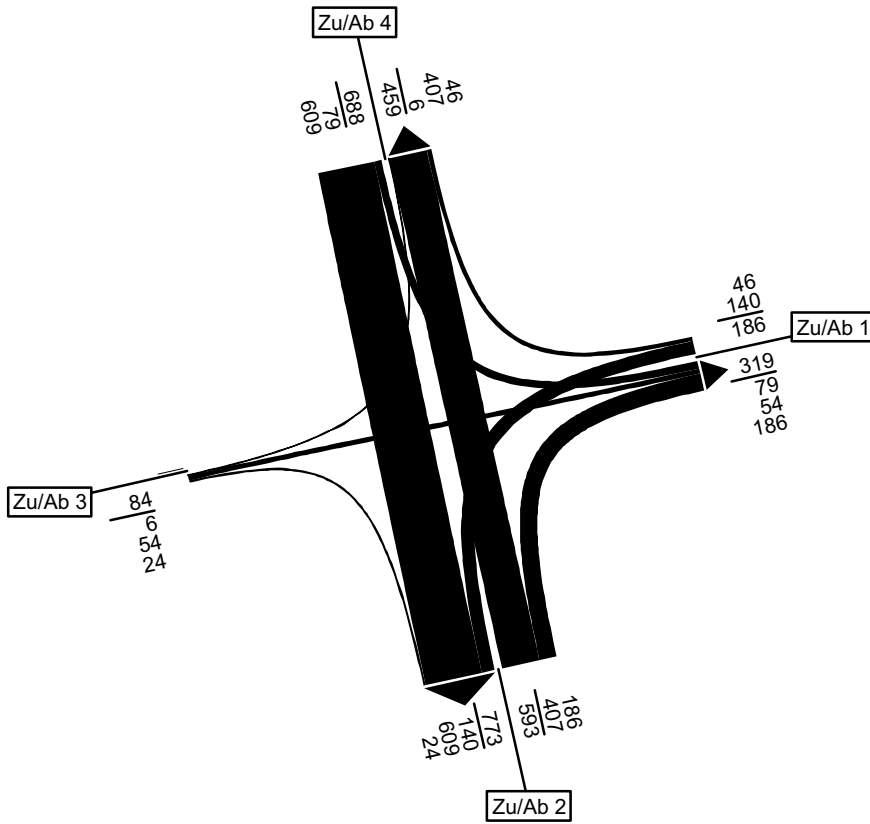

Spezifische Spitzenstunde abends  
16:45 Uhr - 17:45 Uhr in KFZ

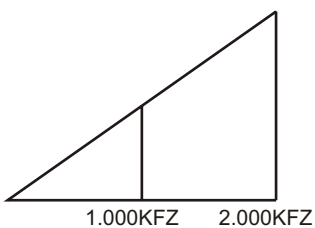
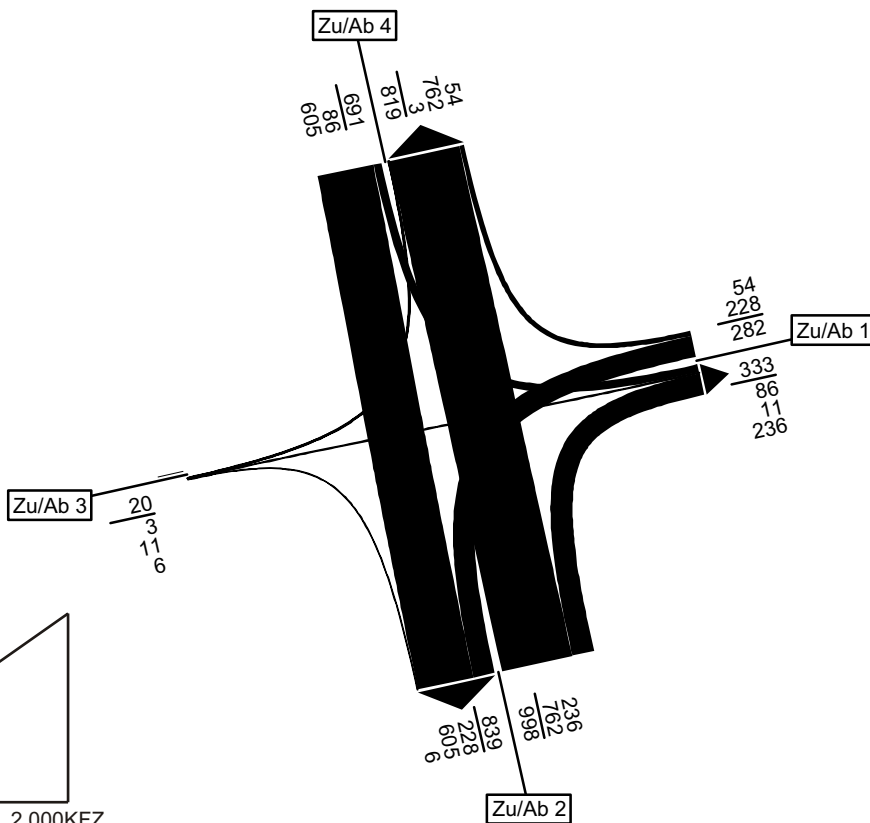

# Stadt Dachau

Zählstelle: K21 Schleißheimer Straße / Frühlingstraße

Zu-/Ablauf 1: Schleißheimer Str. (von/nach Stadtauswärts)

Zu-/Ablauf 2: Frühlingstr.

Zu-/Ablauf 3: Schleißheimer Str. (von/nach Stadteinwärts)

Zu-/Ablauf 4: Martin-Huber-Str.

Zusammenfassung Stundengruppen

Zähltag: Do., 26.04.2007

Zählzeit: 06:00 Uhr - 10:00 Uhr und 15:00 Uhr - 19:00 Uhr

## Summe Zählzeit (06:00 Uhr - 10:00 Uhr und 15:00 Uhr - 19:00 Uhr)

FZ-ART	1-2	1-3	1-4	2-1	2-3	2-4	3-1	3-2	3-4	4-1	4-2	4-3	Zu. 1	Zu. 2	Zu. 3	Zu. 4	Ab. 1	Ab. 2	Ab. 3	Ab. 4	K-Sum
RAD	57	190	91	108	0	90	261	15	6	14	180	1	338	198	282	196	383	252	191	187	1013
KRAD	45	20	18	65	0	28	36	7	11	19	23	0	83	93	54	42	120	75	20	57	272
PKW	1825	997	1066	1860	0	971	1338	262	247	963	888	7	3888	2831	1847	1858	4161	2975	1004	2284	10424
BUS	103	0	0	88	0	19	4	0	0	2	17	0	103	107	4	19	94	120	0	19	233
LFW	62	60	49	113	0	31	50	1	7	32	29	0	171	144	58	61	195	92	60	87	434
LKW	24	13	5	26	0	8	12	3	0	5	8	0	42	34	15	13	43	35	13	13	104
LZ	0	5	0	4	0	2	4	0	0	1	0	0	5	6	4	1	9	0	5	2	16
<b>KFZ</b>	<b>2059</b>	<b>1095</b>	<b>1138</b>	<b>2156</b>	<b>0</b>	<b>1059</b>	<b>1444</b>	<b>273</b>	<b>265</b>	<b>1022</b>	<b>965</b>	<b>7</b>	<b>4292</b>	<b>3215</b>	<b>1982</b>	<b>1994</b>	<b>4622</b>	<b>3297</b>	<b>1102</b>	<b>2462</b>	<b>11483</b>
SV	127	18	5	118	0	29	20	3	0	8	25	0	150	147	23	33	146	155	18	34	353
PV	1973	1017	1084	2013	0	1018	1378	269	258	984	928	7	4074	3031	1905	1919	4375	3170	1024	2360	10929
GV	86	78	54	143	0	41	66	4	7	38	37	0	218	184	77	75	247	127	78	102	554
<b>FZ-ART</b>	<b>1-2</b>	<b>1-3</b>	<b>1-4</b>	<b>2-1</b>	<b>2-3</b>	<b>2-4</b>	<b>3-1</b>	<b>3-2</b>	<b>3-4</b>	<b>4-1</b>	<b>4-2</b>	<b>4-3</b>	<b>Zu. 1</b>	<b>Zu. 2</b>	<b>Zu. 3</b>	<b>Zu. 4</b>	<b>Ab. 1</b>	<b>Ab. 2</b>	<b>Ab. 3</b>	<b>Ab. 4</b>	<b>K-Sum</b>

## Summe Zählintervall 06:00 Uhr - 10:00 Uhr

FZ-ART	1-2	1-3	1-4	2-1	2-3	2-4	3-1	3-2	3-4	4-1	4-2	4-3	Zu. 1	Zu. 2	Zu. 3	Zu. 4	Ab. 1	Ab. 2	Ab. 3	Ab. 4	K-Sum
RAD	24	79	28	75	0	21	143	5	2	9	70	0	131	96	150	79	227	99	79	51	456
KRAD	9	7	4	16	0	4	9	0	3	11	5	0	20	20	12	16	36	14	7	11	68
PKW	637	336	365	706	0	307	486	44	55	580	494	3	1338	1013	585	1077	1772	1175	339	727	4013
BUS	62	0	0	49	0	8	3	0	0	2	14	0	62	57	3	16	54	76	0	8	138
LFW	39	22	25	56	0	9	27	0	3	16	14	0	86	65	30	30	99	53	22	37	211
LKW	13	11	4	19	0	7	8	1	0	4	7	0	28	26	9	11	31	21	11	11	74
LZ	0	4	0	2	0	1	2	0	0	0	0	0	4	3	2	0	4	0	4	1	9
<b>KFZ</b>	<b>760</b>	<b>380</b>	<b>398</b>	<b>848</b>	<b>0</b>	<b>336</b>	<b>535</b>	<b>45</b>	<b>61</b>	<b>613</b>	<b>534</b>	<b>3</b>	<b>1538</b>	<b>1184</b>	<b>641</b>	<b>1150</b>	<b>1996</b>	<b>1339</b>	<b>383</b>	<b>795</b>	<b>4513</b>
SV	75	15	4	70	0	16	13	1	0	6	21	0	94	86	14	27	89	97	15	20	221
PV	708	343	369	771	0	319	498	44	58	593	513	3	1420	1090	600	1109	1862	1265	346	746	4219
GV	52	37	29	77	0	17	37	1	3	20	21	0	118	94	41	41	134	74	37	49	294
<b>FZ-ART</b>	<b>1-2</b>	<b>1-3</b>	<b>1-4</b>	<b>2-1</b>	<b>2-3</b>	<b>2-4</b>	<b>3-1</b>	<b>3-2</b>	<b>3-4</b>	<b>4-1</b>	<b>4-2</b>	<b>4-3</b>	<b>Zu. 1</b>	<b>Zu. 2</b>	<b>Zu. 3</b>	<b>Zu. 4</b>	<b>Ab. 1</b>	<b>Ab. 2</b>	<b>Ab. 3</b>	<b>Ab. 4</b>	<b>K-Sum</b>

## Summe Zählintervall 15:00 Uhr - 19:00 Uhr

FZ-ART	1-2	1-3	1-4	2-1	2-3	2-4	3-1	3-2	3-4	4-1	4-2	4-3	Zu. 1	Zu. 2	Zu. 3	Zu. 4	Ab. 1	Ab. 2	Ab. 3	Ab. 4	K-Sum
RAD	33	111	63	33	0	69	118	10	4	5	110	1	207	102	132	116	156	153	112	136	557
KRAD	36	13	14	49	0	24	27	7	8	8	18	0	63	73	42	26	84	61	13	46	204
PKW	1188	661	701	1154	0	664	852	218	192	383	394	4	2550	1818	1262	781	2389	1800	665	1557	6411
BUS	41	0	0	39	0	11	1	0	0	0	3	0	41	50	1	3	40	44	0	11	95
LFW	23	38	24	57	0	22	23	1	4	16	15	0	85	79	28	31	96	39	38	50	223
LKW	11	2	1	7	0	1	4	2	0	1	1	0	14	8	6	2	12	14	2	2	30
LZ	0	1	0	2	0	1	2	0	0	1	0	0	1	3	2	1	5	0	1	1	7
<b>KFZ</b>	<b>1299</b>	<b>715</b>	<b>740</b>	<b>1308</b>	<b>0</b>	<b>723</b>	<b>909</b>	<b>228</b>	<b>204</b>	<b>409</b>	<b>431</b>	<b>4</b>	<b>2754</b>	<b>2031</b>	<b>1341</b>	<b>844</b>	<b>2626</b>	<b>1958</b>	<b>719</b>	<b>1667</b>	<b>6970</b>
SV	52	3	1	48	0	13	7	2	0	2	4	0	56	61	9	6	57	58	3	14	132
PV	1265	674	715	1242	0	699	880	225	200	391	415	4	2654	1941	1305	810	2513	1905	678	1614	6710
GV	34	41	25	66	0	24	29	3	4	18	16	0	100	90	36	34	113	53	41	53	260
<b>FZ-ART</b>	<b>1-2</b>	<b>1-3</b>	<b>1-4</b>	<b>2-1</b>	<b>2-3</b>	<b>2-4</b>	<b>3-1</b>	<b>3-2</b>	<b>3-4</b>	<b>4-1</b>	<b>4-2</b>	<b>4-3</b>	<b>Zu. 1</b>	<b>Zu. 2</b>	<b>Zu. 3</b>	<b>Zu. 4</b>	<b>Ab. 1</b>	<b>Ab. 2</b>	<b>Ab. 3</b>	<b>Ab. 4</b>	<b>K-Sum</b>

## spezifische Spitzenstunde morgens 09:00 Uhr - 10:00 Uhr

FZ-ART	1-2	1-3	1-4	2-1	2-3	2-4	3-1	3-2	3-4	4-1	4-2	4-3	Zu. 1	Zu. 2	Zu. 3	Zu. 4	Ab. 1	Ab. 2	Ab. 3	Ab. 4	K-Sum
RAD	2	21	9	7	0	4	21	0	0	2	3	0	32	11	21	5	30	5	21	13	69
KRAD	4	2	1	3	0	1	1	0	0	2	1	0	7	4	1	3	6	5	2	2	15
PKW	225	112	135	239	0	104	165	22	30	96	103	0	472	343	217	199	500	350	112	269	1231
BUS	11	0	0	12	0	0	0	0	0	0	2	0	11	12	0	2	12	13	0	0	25
LFW	9	8	7	20	0	3	12	0	0	6	3	0	24	23	12	9	38	12	8	10	68
LKW	3	3	0	5	0	2	1	0	0	2	2	0	6	7	1	4	8	5	3	2	18
LZ	0	1	0	2	0	1	2	0	0	0	0	0	1	1	0	0	1	0	1	0	2
<b>KFZ</b>	<b>252</b>	<b>126</b>	<b>143</b>	<b>280</b>	<b>0</b>	<b>110</b>	<b>179</b>	<b>22</b>	<b>30</b>	<b>106</b>	<b>111</b>	<b>0</b>	<b>521</b>	<b>390</b>	<b>231</b>	<b>217</b>	<b>565</b>	<b>385</b>	<b>126</b>	<b>283</b>	<b>1359</b>
SV	14	4	0	18	0	2	1	0	0	2	4	0	18	20	1	6	21	18	4	2	45
PV	240	114	136	254	0	105	166	22	30	98	106	0	490	359	218	204	518	368	114	271	1271
GV	12	12	7	26	0	5	13	0	0	8	5	0	31	31	13	13	47	17	12	12	88
<b>FZ-ART</b>	<b>1-2</b>	<b>1-3</b>	<b>1-4</b>	<b>2-1</b>	<b>2-3</b>	<b>2-4</b>	<b>3-1</b>	<b>3-2</b>	<b>3-4</b>	<b>4-1</b>	<b>4-2</b>	<b>4-3</b>	<b>Zu. 1</b>	<b>Zu. 2</b>	<b>Zu. 3</b>	<b>Zu. 4</b>	<b>Ab. 1</b>	<b>Ab. 2</b>	<b>Ab. 3</b>	<b>Ab. 4</b>	<b>K-Sum</b>

## spezifische Spitzenstunde abends 16:45 Uhr - 17:45 Uhr

FZ-ART	1-2	1-3	1-4	2-1	2-3	2-4	3-1	3-2	3-4	4-1	4-2	4-3	Zu. 1	Zu. 2	Zu. 3	Zu. 4	Ab. 1	Ab. 2	Ab. 3	Ab. 4	K-Sum
RAD	12	29	12	7	0	12	33	5	2	2	25	0	53	19	40	27	42	42	29	26	139
KRAD	9	6	5	17	0	4	8	0	1	2	2	0	20	21	9	4	27	11	6	10	54
PKW	317	205	247	321	0	208	228	59	59	79	85	0	769	529	346	164	628	461	205	514	1808
BUS	8	0	0	8	0	3	0	0	0	0	2	0	8	11	0	2	8	10	0		

# Stadt Dachau

Zählstelle: K21 Schleißheimer Straße / Frühlingstraße

Zusammenfassung Stundengruppen

Zähltag: Do., 26.04.2007

Zu-/Ablauf 1: Schleißheimer Str. (von/nach Stadtauswärts)

Zu-/Ablauf 2: Frühlingstr.

Zu-/Ablauf 3: Schleißheimer Str. (von/nach Stadteinwärts)

Zu-/Ablauf 4: Martin-Huber-Str.

Spezifische Spitzenstunde morgens  
09:00 Uhr - 10:00 Uhr in KFZ

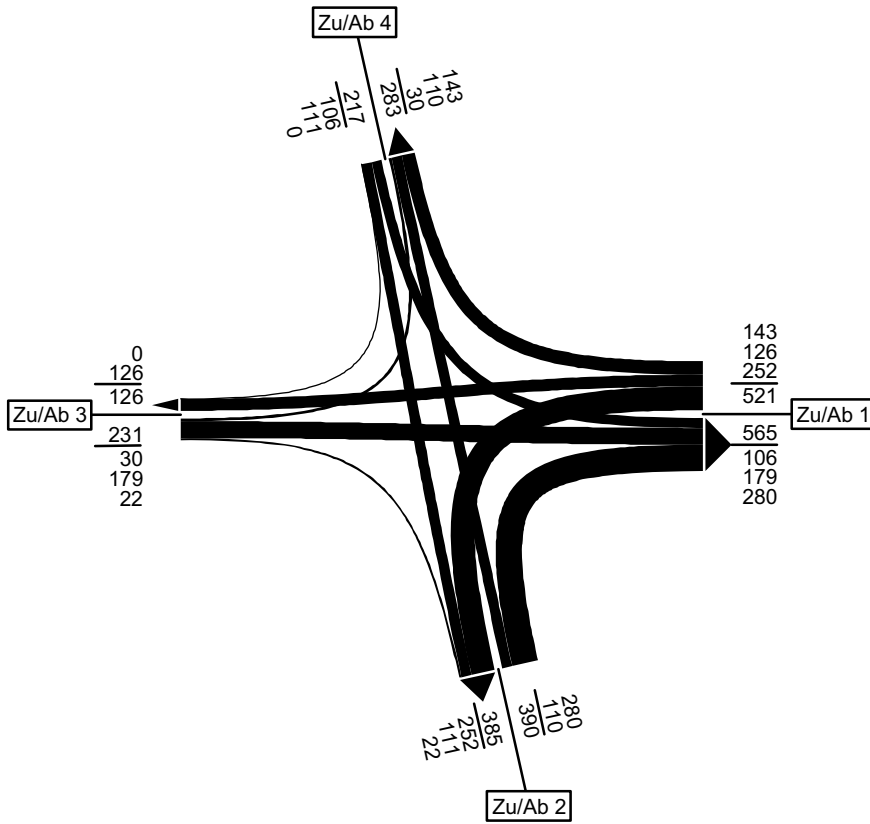

Spezifische Spitzenstunde abends  
16:45 Uhr - 17:45 Uhr in KFZ

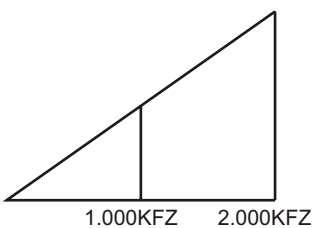
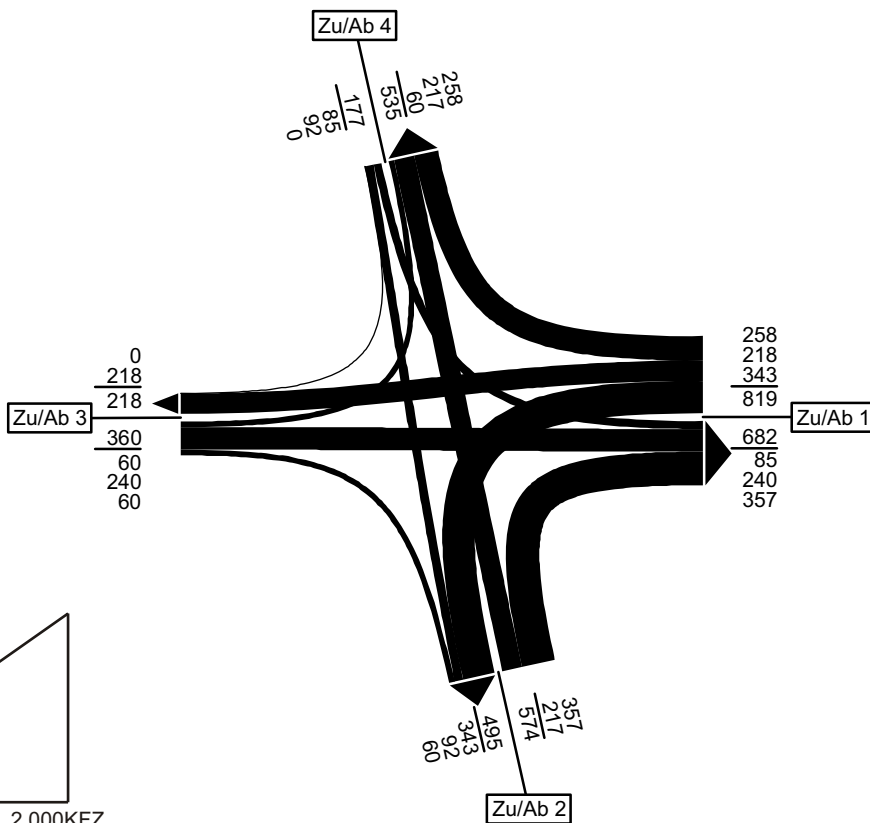

# Stadt Dachau

Zählstelle: K22 Schleißheimer Straße / Pollnstraße

Zu-/Ablauf 1: Pollnstr.

Zu-/Ablauf 2: Schleißheimer Str. (von/nach Stadtauswärts)

Zu-/Ablauf 3: St.-Peter-Str.

Zu-/Ablauf 4: Schleißheimer Str. (von/nach Stadteinwärts)

Zusammenfassung Stundengruppen

Zähltag: Do., 26.04.2007

Zählzeit: 06:00 Uhr - 10:00 Uhr und 15:00 Uhr - 19:00 Uhr

## Summe Zählzeit (06:00 Uhr - 10:00 Uhr und 15:00 Uhr - 19:00 Uhr)

FZ-ART	1-2	1-3	1-4	2-1	2-3	2-4	3-1	3-2	3-4	4-1	4-2	4-3	Zu. 1	Zu. 2	Zu. 3	Zu. 4	Ab. 1	Ab. 2	Ab. 3	Ab. 4	K-Sum
RAD	9	83	139	7	33	368	71	12	46	44	266	30	231	408	129	340	122	287	146	553	1108
KRAD	7	2	9	8	4	84	1	3	0	20	79	0	18	96	4	99	29	89	6	93	217
PKW	516	15	485	394	95	3530	6	162	63	372	3555	39	1016	4019	231	3966	772	4233	149	4078	9232
BUS	2	0	11	3	0	47	0	0	0	5	55	0	13	50	0	60	8	57	0	58	123
LFW	9	1	27	14	3	187	0	1	3	13	155	2	37	204	4	170	27	165	6	217	415
LKW	4	0	3	7	1	37	0	1	1	4	45	0	7	45	2	49	11	50	1	41	103
LZ	0	0	1	0	0	16	0	1	1	0	2	0	1	16	2	2	0	3	0	18	21
<b>KFZ</b>	<b>538</b>	<b>18</b>	<b>536</b>	<b>426</b>	<b>103</b>	<b>3901</b>	<b>7</b>	<b>168</b>	<b>68</b>	<b>414</b>	<b>3891</b>	<b>41</b>	<b>1092</b>	<b>4430</b>	<b>243</b>	<b>4346</b>	<b>847</b>	<b>4597</b>	<b>162</b>	<b>4505</b>	<b>10111</b>
SV	6	0	15	10	1	100	0	2	2	9	102	0	21	111	4	111	19	110	1	117	247
PV	525	17	505	405	99	3661	7	165	63	397	3689	39	1047	4165	235	4125	809	4379	155	4229	9572
GV	13	1	31	21	4	240	0	3	5	17	202	2	45	265	8	221	38	218	7	276	539
<b>FZ-ART</b>	<b>1-2</b>	<b>1-3</b>	<b>1-4</b>	<b>2-1</b>	<b>2-3</b>	<b>2-4</b>	<b>3-1</b>	<b>3-2</b>	<b>3-4</b>	<b>4-1</b>	<b>4-2</b>	<b>4-3</b>	<b>Zu. 1</b>	<b>Zu. 2</b>	<b>Zu. 3</b>	<b>Zu. 4</b>	<b>Ab. 1</b>	<b>Ab. 2</b>	<b>Ab. 3</b>	<b>Ab. 4</b>	<b>K-Sum</b>

## Summe Zählintervall 06:00 Uhr - 10:00 Uhr

FZ-ART	1-2	1-3	1-4	2-1	2-3	2-4	3-1	3-2	3-4	4-1	4-2	4-3	Zu. 1	Zu. 2	Zu. 3	Zu. 4	Ab. 1	Ab. 2	Ab. 3	Ab. 4	K-Sum
RAD	5	41	90	1	14	167	8	1	22	8	94	12	136	182	31	114	17	100	67	279	463
KRAD	2	0	5	1	3	27	0	1	0	3	31	0	7	31	1	34	4	34	3	32	73
PKW	324	8	194	85	29	1101	4	89	38	120	1477	16	526	1215	131	1613	209	1890	53	1333	3485
BUS	1	0	9	3	0	21	0	0	0	4	27	0	10	24	0	31	7	28	0	30	65
LFW	6	0	18	3	2	122	0	0	3	6	88	2	24	127	3	96	9	94	4	143	250
LKW	3	0	3	5	0	31	0	0	1	2	28	0	6	36	1	30	7	31	0	35	73
LZ	0	0	1	0	0	9	0	1	0	0	2	0	1	9	1	2	0	3	0	10	13
<b>KFZ</b>	<b>336</b>	<b>8</b>	<b>230</b>	<b>97</b>	<b>34</b>	<b>1311</b>	<b>4</b>	<b>91</b>	<b>42</b>	<b>135</b>	<b>1653</b>	<b>18</b>	<b>574</b>	<b>1442</b>	<b>137</b>	<b>1806</b>	<b>236</b>	<b>2080</b>	<b>60</b>	<b>1583</b>	<b>3959</b>
SV	4	0	13	8	0	61	0	1	1	6	57	0	17	69	2	63	14	62	0	75	151
PV	327	8	208	89	32	1149	4	90	38	127	1535	16	543	1270	132	1678	220	1952	56	1395	3623
GV	9	0	22	8	2	162	0	1	4	8	118	2	31	172	5	128	16	128	4	188	336
<b>FZ-ART</b>	<b>1-2</b>	<b>1-3</b>	<b>1-4</b>	<b>2-1</b>	<b>2-3</b>	<b>2-4</b>	<b>3-1</b>	<b>3-2</b>	<b>3-4</b>	<b>4-1</b>	<b>4-2</b>	<b>4-3</b>	<b>Zu. 1</b>	<b>Zu. 2</b>	<b>Zu. 3</b>	<b>Zu. 4</b>	<b>Ab. 1</b>	<b>Ab. 2</b>	<b>Ab. 3</b>	<b>Ab. 4</b>	<b>K-Sum</b>

## Summe Zählintervall 15:00 Uhr - 19:00 Uhr

FZ-ART	1-2	1-3	1-4	2-1	2-3	2-4	3-1	3-2	3-4	4-1	4-2	4-3	Zu. 1	Zu. 2	Zu. 3	Zu. 4	Ab. 1	Ab. 2	Ab. 3	Ab. 4	K-Sum
RAD	4	42	49	6	19	201	63	11	24	36	172	18	95	226	98	226	105	187	79	274	645
KRAD	5	2	4	7	1	57	1	2	0	17	48	0	11	65	3	65	25	55	3	61	144
PKW	192	7	291	309	66	2429	2	73	25	252	2078	23	490	2804	100	2353	563	2343	96	2745	5747
BUS	1	0	2	0	0	26	0	0	0	1	28	0	3	26	0	29	1	29	0	28	58
LFW	3	1	9	11	1	65	0	1	0	7	67	0	13	77	1	74	18	71	2	74	165
LKW	1	0	0	2	1	6	0	1	0	2	17	0	1	9	1	19	4	19	1	6	30
LZ	0	0	0	0	0	7	0	0	1	0	0	0	0	7	1	0	0	0	0	8	8
<b>KFZ</b>	<b>202</b>	<b>10</b>	<b>306</b>	<b>329</b>	<b>69</b>	<b>2590</b>	<b>3</b>	<b>77</b>	<b>26</b>	<b>279</b>	<b>2238</b>	<b>23</b>	<b>518</b>	<b>2988</b>	<b>106</b>	<b>2540</b>	<b>611</b>	<b>2517</b>	<b>102</b>	<b>2922</b>	<b>6152</b>
SV	2	0	2	2	1	39	0	1	1	3	45	0	4	42	2	48	5	48	1	42	96
PV	198	9	297	316	67	2512	3	75	25	270	2154	23	504	2895	103	2447	589	2427	99	2834	5949
GV	4	1	9	13	2	78	0	2	1	9	84	0	14	93	3	93	22	90	3	88	203
<b>FZ-ART</b>	<b>1-2</b>	<b>1-3</b>	<b>1-4</b>	<b>2-1</b>	<b>2-3</b>	<b>2-4</b>	<b>3-1</b>	<b>3-2</b>	<b>3-4</b>	<b>4-1</b>	<b>4-2</b>	<b>4-3</b>	<b>Zu. 1</b>	<b>Zu. 2</b>	<b>Zu. 3</b>	<b>Zu. 4</b>	<b>Ab. 1</b>	<b>Ab. 2</b>	<b>Ab. 3</b>	<b>Ab. 4</b>	<b>K-Sum</b>

## spezifische Spitzenstunde morgens 07:45 Uhr - 08:45 Uhr

FZ-ART	1-2	1-3	1-4	2-1	2-3	2-4	3-1	3-2	3-4	4-1	4-2	4-3	Zu. 1	Zu. 2	Zu. 3	Zu. 4	Ab. 1	Ab. 2	Ab. 3	Ab. 4	K-Sum
RAD	1	19	35	0	3	37	2	1	14	1	41	7	55	40	17	49	3	43	29	86	161
KRAD	0	0	1	0	0	9	0	0	0	2	8	0	1	9	0	10	2	8	0	10	20
PKW	91	1	56	29	11	343	0	20	11	40	442	6	148	383	31	488	69	553	18	410	1050
BUS	0	0	2	1	0	4	0	0	0	1	9	0	2	5	0	10	2	9	0	6	17
LFW	0	0	5	0	0	34	0	0	3	3	30	1	5	34	3	34	3	30	1	42	76
LKW	1	0	0	2	0	7	0	0	0	0	9	0	2	9	0	9	2	10	0	8	20
LZ	0	0	0	0	0	1	0	0	0	0	0	0	0	1	0	0	0	0	0	1	1
<b>KFZ</b>	<b>92</b>	<b>1</b>	<b>65</b>	<b>32</b>	<b>11</b>	<b>398</b>	<b>0</b>	<b>20</b>	<b>14</b>	<b>46</b>	<b>498</b>	<b>7</b>	<b>158</b>	<b>441</b>	<b>34</b>	<b>551</b>	<b>78</b>	<b>610</b>	<b>19</b>	<b>477</b>	<b>1184</b>
SV	1	0	3	3	0	12	0	0	0	1	18	0	4	15	0	19	4	19	0	15	38
PV	91	1	59	30	11	356	0	20	11	43	459	6	151	397	31	508	73	570	18	426	1087
GV	1	0	6	2	0	42	0	0	3	3	39	1	7	44	3	43	5	40	1	51	97
<b>FZ-ART</b>	<b>1-2</b>	<b>1-3</b>	<b>1-4</b>	<b>2-1</b>	<b>2-3</b>	<b>2-4</b>	<b>3-1</b>	<b>3-2</b>	<b>3-4</b>	<b>4-1</b>	<b>4-2</b>	<b>4-3</b>	<b>Zu. 1</b>	<b>Zu. 2</b>	<b>Zu. 3</b>	<b>Zu. 4</b>	<b>Ab. 1</b>	<b>Ab. 2</b>	<b>Ab. 3</b>	<b>Ab. 4</b>	<b>K-Sum</b>

## spezifische Spitzenstunde abends 16:30 Uhr - 17:30 Uhr

FZ-ART	1-2	1-3	1-4	2-1	2-3	2-4	3-1	3-2	3-4	4-1	4-2	4-3	Zu. 1	Zu. 2	Zu. 3	Zu. 4	Ab. 1	Ab. 2	Ab. 3	Ab. 4	K-Sum
RAD	0	10	19	0	9	62	23	3	9	3	62	8	29	71	35	73	26	65	27	90	208
KRAD	1	0	1	1	0	15	0	1	0	7	16	0	2	16	1	23	8	18	0	16	42
PKW	51	1	107	85	19	667	1	17	8	92	529	1	159	771	26	622	178	597	21	782	1578
BUS	0	0	0	0	0	7	0	0	0	0	6	0	0	7	0	6	0	6	0	7	13
LFW	1	0	2	3	0	11	0	0	0	3	16	0	3	14	0	19	6	17	0		

# Stadt Dachau

Zählstelle: K22 Schleißheimer Straße / Pollnstraße

Zusammenfassung Stundengruppen

Zähltag: Do., 26.04.2007

Zu-/Ablauf 1: Pollnstr.

Zu-/Ablauf 2: Schleißheimer Str. (von/nach Stadtauswärts)

Zu-/Ablauf 3: St.-Peter-Str.

Zu-/Ablauf 4: Schleißheimer Str. (von/nach Stadteinwärts)

Spezifische Spitzenstunde morgens  
07:45 Uhr - 08:45 Uhr in KFZ

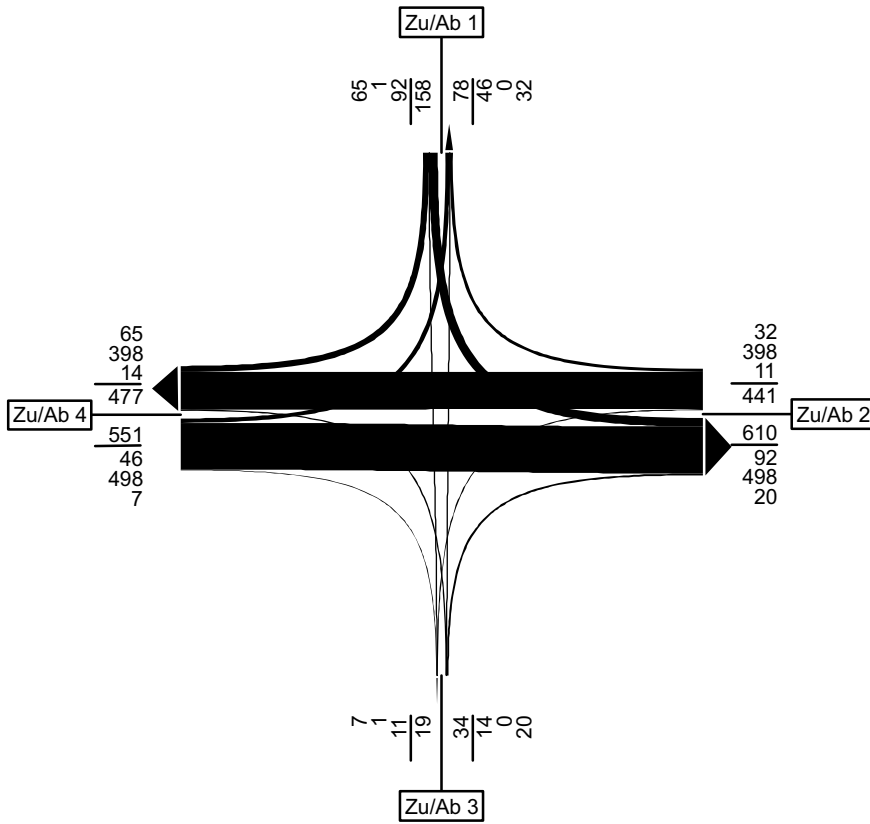

Spezifische Spitzenstunde abends  
16:30 Uhr - 17:30 Uhr in KFZ

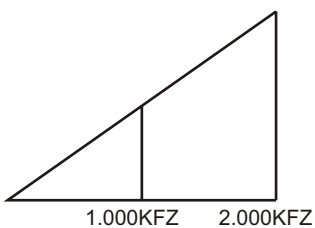
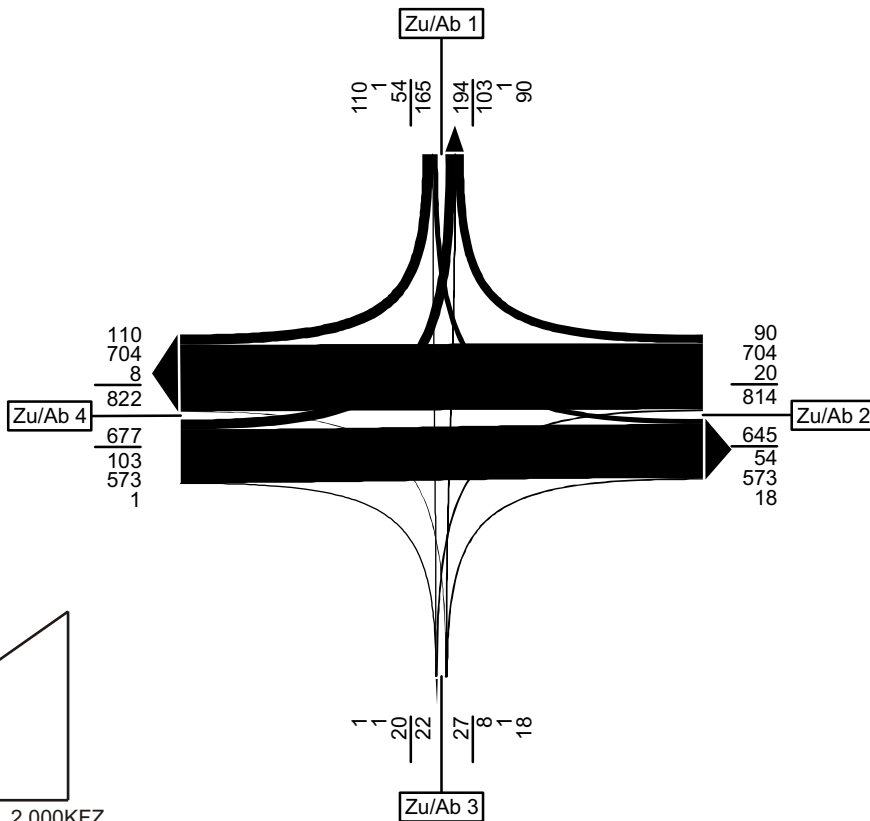

**Stadt Dachau**

Zählstelle: K23 Schleißheimer Straße / Würmstraße

Zu-/Ablauf 1: Würmstr.

Zu-/Ablauf 2: Schleißheimer Str. (von/nach Stadtauswärts)

Zu-/Ablauf 3: Schleißheimer Str. (von/nach Stadteinwärts)

Zusammenfassung Stundengruppen

Zähltag: Do., 26.10.2006

Zählzeit: 06:00 Uhr - 10:00 Uhr und 15:00 Uhr - 19:00 Uhr

**Summe Zähizeit (06:00 Uhr - 10:00 Uhr und 15:00 Uhr - 19:00 Uhr)**

FZ-ART	1-2	1-3	1-4	2-1	2-3	2-4	3-1	3-2	3-4	4-1	4-2	4-3	Zu. 1	Zu. 2	Zu. 3	Zu. 4	Ab. 1	Ab. 2	Ab. 3	Ab. 4	K-Sum
RAD	7	14	0	121	74	0	18	193	0	0	0	0	21	195	211	0	139	200	88	0	427
KRAD	10	12	0	16	56	0	21	83	0	0	0	0	22	72	104	0	37	93	68	0	198
PKW	447	843	0	374	3126	0	967	3143	0	0	0	0	1290	3500	4110	0	1341	3590	3969	0	8900
BUS	1	42	0	0	9	0	25	49	0	0	0	0	43	9	74	0	25	50	51	0	126
LFW	30	50	0	31	178	0	42	263	0	0	0	0	80	209	305	0	73	293	228	0	594
LKW	4	16	0	4	121	0	7	163	0	0	0	0	20	125	170	0	11	167	137	0	315
LZ	0	1	0	4	46	0	10	32	0	0	0	0	1	50	42	0	14	32	47	0	93
<b>KFZ</b>	<b>492</b>	<b>964</b>	<b>0</b>	<b>429</b>	<b>3536</b>	<b>0</b>	<b>1072</b>	<b>3733</b>	<b>0</b>	<b>0</b>	<b>0</b>	<b>0</b>	<b>1456</b>	<b>3965</b>	<b>4805</b>	<b>0</b>	<b>1501</b>	<b>4225</b>	<b>4500</b>	<b>0</b>	<b>10226</b>
SV	5	59	0	8	176	0	42	244	0	0	0	0	64	184	286	0	50	249	235	0	534
PV	458	897	0	390	3191	0	1013	3275	0	0	0	0	1355	3581	4288	0	1403	3733	4088	0	9224
GV	34	67	0	39	345	0	59	458	0	0	0	0	101	384	517	0	98	492	412	0	1002
<b>FZ-ART</b>	<b>1-2</b>	<b>1-3</b>	<b>1-4</b>	<b>2-1</b>	<b>2-3</b>	<b>2-4</b>	<b>3-1</b>	<b>3-2</b>	<b>3-4</b>	<b>4-1</b>	<b>4-2</b>	<b>4-3</b>	<b>Zu. 1</b>	<b>Zu. 2</b>	<b>Zu. 3</b>	<b>Zu. 4</b>	<b>Ab. 1</b>	<b>Ab. 2</b>	<b>Ab. 3</b>	<b>Ab. 4</b>	<b>K-Sum</b>

**Summe Zählintervall 06:00 Uhr - 10:00 Uhr**

FZ-ART	1-2	1-3	1-4	2-1	2-3	2-4	3-1	3-2	3-4	4-1	4-2	4-3	Zu. 1	Zu. 2	Zu. 3	Zu. 4	Ab. 1	Ab. 2	Ab. 3	Ab. 4	K-Sum
RAD	4	4	0	32	37	0	4	65	0	0	0	0	8	69	69	0	36	69	41	0	146
KRAD	6	6	0	6	11	0	6	38	0	0	0	0	12	17	44	0	12	44	17	0	73
PKW	281	359	0	102	928	0	380	1413	0	0	0	0	640	1030	1793	0	482	1694	1287	0	3463
BUS	1	26	0	0	5	0	13	30	0	0	0	0	27	5	43	0	13	31	31	0	75
LFW	23	25	0	13	93	0	19	147	0	0	0	0	48	106	166	0	32	170	118	0	320
LKW	3	10	0	3	64	0	4	88	0	0	0	0	13	67	92	0	7	91	74	0	172
LZ	0	1	0	2	27	0	7	16	0	0	0	0	1	29	23	0	9	16	28	0	53
<b>KFZ</b>	<b>314</b>	<b>427</b>	<b>0</b>	<b>126</b>	<b>1128</b>	<b>0</b>	<b>429</b>	<b>1732</b>	<b>0</b>	<b>0</b>	<b>0</b>	<b>0</b>	<b>741</b>	<b>1254</b>	<b>2161</b>	<b>0</b>	<b>555</b>	<b>2046</b>	<b>1555</b>	<b>0</b>	<b>4156</b>
SV	4	37	0	5	96	0	24	134	0	0	0	0	41	101	158	0	29	138	133	0	300
PV	288	391	0	108	944	0	399	1481	0	0	0	0	679	1052	1880	0	507	1769	1335	0	3611
GV	26	36	0	18	184	0	30	251	0	0	0	0	62	202	281	0	48	277	220	0	545
<b>FZ-ART</b>	<b>1-2</b>	<b>1-3</b>	<b>1-4</b>	<b>2-1</b>	<b>2-3</b>	<b>2-4</b>	<b>3-1</b>	<b>3-2</b>	<b>3-4</b>	<b>4-1</b>	<b>4-2</b>	<b>4-3</b>	<b>Zu. 1</b>	<b>Zu. 2</b>	<b>Zu. 3</b>	<b>Zu. 4</b>	<b>Ab. 1</b>	<b>Ab. 2</b>	<b>Ab. 3</b>	<b>Ab. 4</b>	<b>K-Sum</b>

**Summe Zählintervall 15:00 Uhr - 19:00 Uhr**

FZ-ART	1-2	1-3	1-4	2-1	2-3	2-4	3-1	3-2	3-4	4-1	4-2	4-3	Zu. 1	Zu. 2	Zu. 3	Zu. 4	Ab. 1	Ab. 2	Ab. 3	Ab. 4	K-Sum
RAD	3	10	0	89	37	0	14	128	0	0	0	0	13	126	142	0	103	131	47	0	281
KRAD	4	6	0	10	45	0	15	45	0	0	0	0	10	55	60	0	25	49	51	0	125
PKW	166	484	0	272	2198	0	587	1730	0	0	0	0	650	2470	2317	0	859	1896	2682	0	5437
BUS	0	16	0	0	4	0	12	19	0	0	0	0	16	4	31	0	12	19	20	0	51
LFW	7	25	0	18	85	0	23	116	0	0	0	0	32	103	139	0	41	123	110	0	274
LKW	1	6	0	1	57	0	3	75	0	0	0	0	7	58	78	0	4	76	63	0	143
LZ	0	0	0	2	19	0	3	16	0	0	0	0	0	21	19	0	5	16	19	0	40
<b>KFZ</b>	<b>178</b>	<b>537</b>	<b>0</b>	<b>303</b>	<b>2408</b>	<b>0</b>	<b>643</b>	<b>2001</b>	<b>0</b>	<b>0</b>	<b>0</b>	<b>0</b>	<b>715</b>	<b>2711</b>	<b>2644</b>	<b>0</b>	<b>946</b>	<b>2179</b>	<b>2945</b>	<b>0</b>	<b>6070</b>
SV	1	22	0	3	80	0	18	110	0	0	0	0	23	83	128	0	21	111	102	0	234
PV	170	506	0	282	2247	0	614	1794	0	0	0	0	676	2529	2408	0	896	1964	2753	0	5613
GV	8	31	0	21	161	0	29	207	0	0	0	0	39	182	236	0	50	215	192	0	457
<b>FZ-ART</b>	<b>1-2</b>	<b>1-3</b>	<b>1-4</b>	<b>2-1</b>	<b>2-3</b>	<b>2-4</b>	<b>3-1</b>	<b>3-2</b>	<b>3-4</b>	<b>4-1</b>	<b>4-2</b>	<b>4-3</b>	<b>Zu. 1</b>	<b>Zu. 2</b>	<b>Zu. 3</b>	<b>Zu. 4</b>	<b>Ab. 1</b>	<b>Ab. 2</b>	<b>Ab. 3</b>	<b>Ab. 4</b>	<b>K-Sum</b>

**spezifische Spitzenstunde morgens 07:15 Uhr - 08:15 Uhr**

FZ-ART	1-2	1-3	1-4	2-1	2-3	2-4	3-1	3-2	3-4	4-1	4-2	4-3	Zu. 1	Zu. 2	Zu. 3	Zu. 4	Ab. 1	Ab. 2	Ab. 3	Ab. 4	K-Sum
RAD	1	3	0	12	22	0	0	20	0	0	0	0	4	34	20	0	12	21	25	0	58
KRAD	3	4	0	3	4	0	2	11	0	0	0	0	7	7	13	0	5	14	8	0	27
PKW	75	125	0	29	262	0	109	402	0	0	0	0	200	291	511	0	138	477	387	0	1002
BUS	0	6	0	0	1	0	3	9	0	0	0	0	6	1	12	0	3	9	7	0	19
LFW	9	9	0	4	28	0	3	55	0	0	0	0	18	32	58	0	7	64	37	0	108
LKW	1	3	0	0	13	0	1	25	0	0	0	0	4	13	26	0	1	26	16	0	43
LZ	0	0	0	2	8	0	0	8	0	0	0	0	0	10	8	0	2	8	8	0	18
<b>KFZ</b>	<b>88</b>	<b>147</b>	<b>0</b>	<b>38</b>	<b>316</b>	<b>0</b>	<b>118</b>	<b>510</b>	<b>0</b>	<b>0</b>	<b>0</b>	<b>0</b>	<b>235</b>	<b>354</b>	<b>628</b>	<b>0</b>	<b>156</b>	<b>598</b>	<b>463</b>	<b>0</b>	<b>1217</b>
SV	1	9	0	2	22	0	4	42	0	0	0	0	10	24	46	0	6	43	31	0	80
PV	78	135	0	32	267	0	114	422	0	0	0	0	213	299	536	0	146	500	402	0	1048
GV	10	12	0	6	49	0	4	88	0	0	0	0	22	55	92	0	10	98	61	0	169
<b>FZ-ART</b>	<b>1-2</b>	<b>1-3</b>	<b>1-4</b>	<b>2-1</b>	<b>2-3</b>	<b>2-4</b>	<b>3-1</b>	<b>3-2</b>	<b>3-4</b>	<b>4-1</b>	<b>4-2</b>	<b>4-3</b>	<b>Zu. 1</b>	<b>Zu. 2</b>	<b>Zu. 3</b>	<b>Zu. 4</b>	<b>Ab. 1</b>	<b>Ab. 2</b>	<b>Ab. 3</b>	<b>Ab. 4</b>	<b>K-Sum</b>

**spezifische Spitzenstunde abends 16:30 Uhr - 17:30 Uhr**

FZ-ART	1-2	1-3	1-4	2-1	2-3	2-4	3-1	3-2	3-4	4-1	4-2	4-3	Zu. 1	Zu. 2	Zu. 3	Zu. 4	Ab. 1	Ab. 2	Ab. 3	Ab. 4	K-Sum
RAD	2	7	0	22	12	0	6	33	0	0	0	0	9	34	39	0	28	35	19	0	82
KRAD	2	1	0	4	16	0	3	11	0	0	0	0	3	20	14	0	7	13	17	0	37
PKW	47	152	0	66	716	0	182	471	0	0	0	0	199	782	653	0	248	518	868	0	1634
BUS	0	4	0	0	1	0	3	6	0	0	0	0	4	1	9	0	3	6	5	0	14
LFW	1	5	0	5	17	0	5	30	0	0	0	0	6	22	35	0	10	31	22	0	63
LKW	0	1	0	0	10																

# Stadt Dachau

Zählstelle: K23 Schleißheimer Straße / Würmstraße

Zusammenfassung Stundengruppen

Zähltag: Do., 26.10.2006

Zu-/Ablauf 1: Würmstr.

Zu-/Ablauf 2: Schleißheimer Str. (von/nach Stadtauswärts)

Zu-/Ablauf 3: Schleißheimer Str. (von/nach Stadteinwärts)

Spezifische Spitzenstunde morgens  
07:15 Uhr - 08:15 Uhr in KFZ

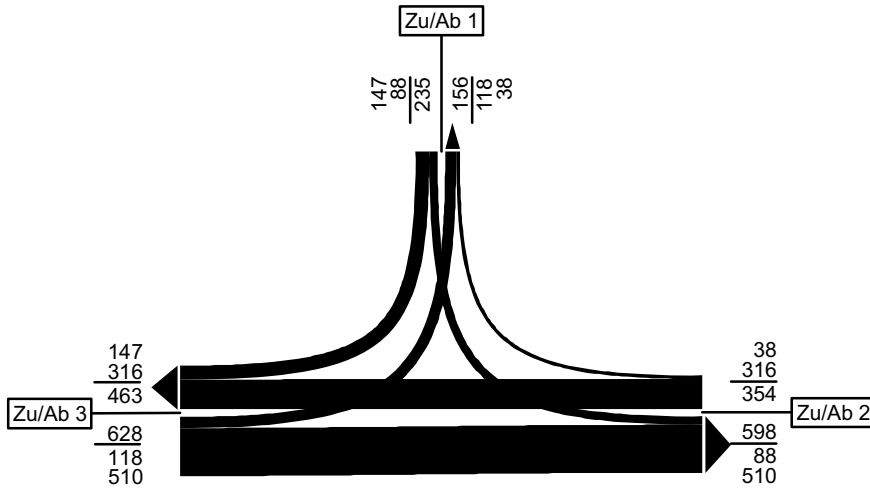

Spezifische Spitzenstunde abends  
16:30 Uhr - 17:30 Uhr in KFZ

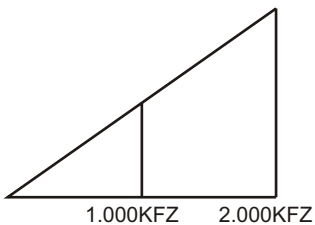
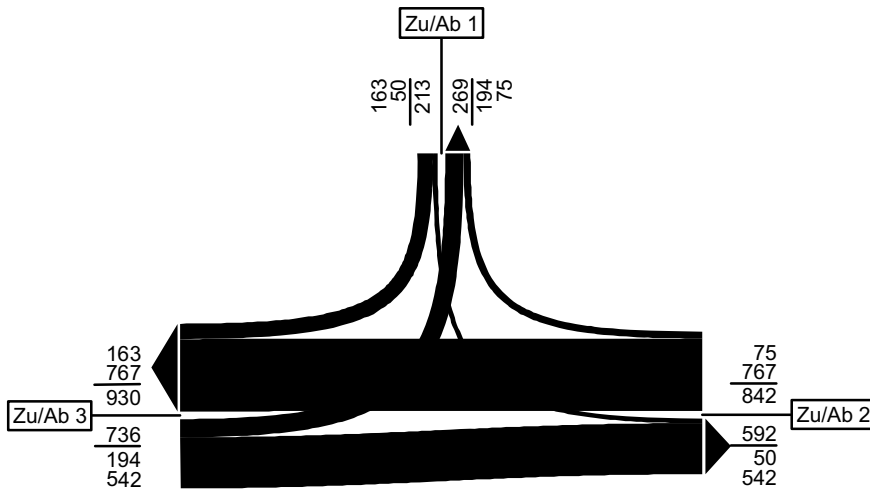

**Stadt Dachau**

Zählstelle: K24 Schleißheimer Straße / Kopernikusstraße

Zu-/Ablauf 1: Kopernikusstr.

Zu-/Ablauf 2: Schleißheimer Str. (von/nach Stadtauswärts)

Zu-/Ablauf 3: Schleißheimer Str. (von/nach Stadteinwärts)

Zusammenfassung Stundengruppen

Zähltag: Do., 26.10.2006

Zählzeit: 06:00 Uhr - 10:00 Uhr und 15:00 Uhr - 19:00 Uhr

**Summe Zählzeit (06:00 Uhr - 10:00 Uhr und 15:00 Uhr - 19:00 Uhr)**

FZ-ART	1-2	1-3	1-4	2-1	2-3	2-4	3-1	3-2	3-4	4-1	4-2	4-3	Zu. 1	Zu. 2	Zu. 3	Zu. 4	Ab. 1	Ab. 2	Ab. 3	Ab. 4	K-Sum
RAD	33	7	0	22	78	0	10	160	0	0	0	0	40	100	170	0	32	193	85	0	310
KRAD	29	17	0	15	37	0	29	65	0	0	0	0	46	52	94	0	44	94	54	0	192
PKW	1503	846	0	984	1693	0	1487	1850	0	0	0	0	2349	2677	3337	0	2471	3353	2539	0	8363
BUS	25	0	0	0	22	0	16	36	0	0	0	0	25	22	52	0	16	61	22	0	99
LFW	125	43	0	55	233	0	117	179	0	0	0	0	168	288	296	0	172	304	276	0	752
LKW	122	32	0	54	108	0	86	124	0	0	0	0	154	162	210	0	140	246	140	0	526
LZ	21	10	0	6	72	0	8	76	0	0	0	0	31	78	84	0	14	97	82	0	193
<b>KFZ</b>	<b>1825</b>	<b>948</b>	<b>0</b>	<b>1114</b>	<b>2165</b>	<b>0</b>	<b>1743</b>	<b>2330</b>	<b>0</b>	<b>0</b>	<b>0</b>	<b>0</b>	<b>2773</b>	<b>3279</b>	<b>4073</b>	<b>0</b>	<b>2857</b>	<b>4155</b>	<b>3113</b>	<b>0</b>	<b>10125</b>
SV	168	42	0	60	202	0	110	236	0	0	0	0	210	262	346	0	170	404	244	0	818
PV	1557	863	0	999	1752	0	1532	1951	0	0	0	0	2420	2751	3483	0	2531	3508	2615	0	8654
GV	268	85	0	115	413	0	211	379	0	0	0	0	353	528	590	0	326	647	498	0	1471
<b>FZ-ART</b>	<b>1-2</b>	<b>1-3</b>	<b>1-4</b>	<b>2-1</b>	<b>2-3</b>	<b>2-4</b>	<b>3-1</b>	<b>3-2</b>	<b>3-4</b>	<b>4-1</b>	<b>4-2</b>	<b>4-3</b>	<b>Zu. 1</b>	<b>Zu. 2</b>	<b>Zu. 3</b>	<b>Zu. 4</b>	<b>Ab. 1</b>	<b>Ab. 2</b>	<b>Ab. 3</b>	<b>Ab. 4</b>	<b>K-Sum</b>

**Summe Zählintervall 06:00 Uhr - 10:00 Uhr**

FZ-ART	1-2	1-3	1-4	2-1	2-3	2-4	3-1	3-2	3-4	4-1	4-2	4-3	Zu. 1	Zu. 2	Zu. 3	Zu. 4	Ab. 1	Ab. 2	Ab. 3	Ab. 4	K-Sum
RAD	6	0	0	6	29	0	3	60	0	0	0	0	6	35	63	0	9	66	29	0	104
KRAD	11	0	0	6	10	0	7	40	0	0	0	0	11	16	47	0	13	51	10	0	74
PKW	697	194	0	275	588	0	602	971	0	0	0	0	891	863	1573	0	877	1668	782	0	3327
BUS	13	0	0	0	6	0	12	25	0	0	0	0	13	6	37	0	12	38	6	0	56
LFW	67	24	0	23	101	0	65	89	0	0	0	0	91	124	154	0	88	156	125	0	369
LKW	68	16	0	29	64	0	32	72	0	0	0	0	84	93	104	0	61	140	80	0	281
LZ	15	4	0	3	44	0	5	27	0	0	0	0	19	47	32	0	8	42	48	0	98
<b>KFZ</b>	<b>871</b>	<b>238</b>	<b>0</b>	<b>336</b>	<b>813</b>	<b>0</b>	<b>723</b>	<b>1224</b>	<b>0</b>	<b>0</b>	<b>0</b>	<b>0</b>	<b>1109</b>	<b>1149</b>	<b>1947</b>	<b>0</b>	<b>1059</b>	<b>2095</b>	<b>1051</b>	<b>0</b>	<b>4205</b>
SV	96	20	0	32	114	0	49	124	0	0	0	0	116	146	173	0	81	220	134	0	435
PV	721	194	0	281	604	0	621	1036	0	0	0	0	915	885	1657	0	902	1757	798	0	3457
GV	150	44	0	55	209	0	102	188	0	0	0	0	194	264	290	0	157	338	253	0	748
<b>FZ-ART</b>	<b>1-2</b>	<b>1-3</b>	<b>1-4</b>	<b>2-1</b>	<b>2-3</b>	<b>2-4</b>	<b>3-1</b>	<b>3-2</b>	<b>3-4</b>	<b>4-1</b>	<b>4-2</b>	<b>4-3</b>	<b>Zu. 1</b>	<b>Zu. 2</b>	<b>Zu. 3</b>	<b>Zu. 4</b>	<b>Ab. 1</b>	<b>Ab. 2</b>	<b>Ab. 3</b>	<b>Ab. 4</b>	<b>K-Sum</b>

**Summe Zählintervall 15:00 Uhr - 19:00 Uhr**

FZ-ART	1-2	1-3	1-4	2-1	2-3	2-4	3-1	3-2	3-4	4-1	4-2	4-3	Zu. 1	Zu. 2	Zu. 3	Zu. 4	Ab. 1	Ab. 2	Ab. 3	Ab. 4	K-Sum
RAD	27	7	0	16	49	0	7	100	0	0	0	0	34	65	107	0	23	127	56	0	206
KRAD	18	17	0	9	27	0	22	25	0	0	0	0	35	36	47	0	31	43	44	0	118
PKW	806	652	0	709	1105	0	885	879	0	0	0	0	1458	1814	1764	0	1594	1685	1757	0	5036
BUS	12	0	0	0	16	0	4	11	0	0	0	0	12	16	15	0	4	23	16	0	43
LFW	58	19	0	32	132	0	52	90	0	0	0	0	77	164	142	0	84	148	151	0	383
LKW	54	16	0	25	44	0	54	52	0	0	0	0	70	69	106	0	79	106	60	0	245
LZ	6	6	0	3	28	0	3	49	0	0	0	0	12	31	52	0	6	55	34	0	95
<b>KFZ</b>	<b>954</b>	<b>710</b>	<b>0</b>	<b>778</b>	<b>1352</b>	<b>0</b>	<b>1020</b>	<b>1106</b>	<b>0</b>	<b>0</b>	<b>0</b>	<b>0</b>	<b>1664</b>	<b>2130</b>	<b>2126</b>	<b>0</b>	<b>1798</b>	<b>2060</b>	<b>2062</b>	<b>0</b>	<b>5920</b>
SV	72	22	0	28	88	0	61	112	0	0	0	0	94	116	173	0	89	184	110	0	383
PV	836	669	0	718	1148	0	911	915	0	0	0	0	1505	1866	1826	0	1629	1751	1817	0	5197
GV	118	41	0	60	204	0	109	191	0	0	0	0	159	264	300	0	169	309	245	0	723
<b>FZ-ART</b>	<b>1-2</b>	<b>1-3</b>	<b>1-4</b>	<b>2-1</b>	<b>2-3</b>	<b>2-4</b>	<b>3-1</b>	<b>3-2</b>	<b>3-4</b>	<b>4-1</b>	<b>4-2</b>	<b>4-3</b>	<b>Zu. 1</b>	<b>Zu. 2</b>	<b>Zu. 3</b>	<b>Zu. 4</b>	<b>Ab. 1</b>	<b>Ab. 2</b>	<b>Ab. 3</b>	<b>Ab. 4</b>	<b>K-Sum</b>

**spezifische Spitzenstunde morgens 07:15 Uhr - 08:15 Uhr**

FZ-ART	1-2	1-3	1-4	2-1	2-3	2-4	3-1	3-2	3-4	4-1	4-2	4-3	Zu. 1	Zu. 2	Zu. 3	Zu. 4	Ab. 1	Ab. 2	Ab. 3	Ab. 4	K-Sum
RAD	1	0	0	1	17	0	2	17	0	0	0	0	1	18	19	0	3	18	17	0	38
KRAD	2	0	0	2	5	0	2	13	0	0	0	0	2	7	15	0	4	15	5	0	24
PKW	218	56	0	75	180	0	154	311	0	0	0	0	274	255	465	0	229	529	236	0	994
BUS	3	0	0	0	0	0	4	4	0	0	0	0	3	0	8	0	4	7	0	0	11
LFW	19	10	0	6	41	0	23	27	0	0	0	0	29	47	50	0	29	46	51	0	126
LKW	14	8	0	8	19	0	6	19	0	0	0	0	22	27	25	0	14	33	27	0	74
LZ	4	0	0	0	12	0	1	8	0	0	0	0	4	12	9	0	1	12	12	0	25
<b>KFZ</b>	<b>260</b>	<b>74</b>	<b>0</b>	<b>91</b>	<b>257</b>	<b>0</b>	<b>190</b>	<b>382</b>	<b>0</b>	<b>0</b>	<b>0</b>	<b>0</b>	<b>334</b>	<b>348</b>	<b>572</b>	<b>0</b>	<b>281</b>	<b>642</b>	<b>331</b>	<b>0</b>	<b>1254</b>
SV	21	8	0	8	31	0	11	31	0	0	0	0	29	39	42	0	19	52	39	0	110
PV	223	56	0	77	185	0	160	328	0	0	0	0	279	262	488	0	237	551	241	0	1029
GV	37	18	0	14	72	0	30	54	0	0	0	0	55	86	84	0	44	91	90	0	225
<b>FZ-ART</b>	<b>1-2</b>	<b>1-3</b>	<b>1-4</b>	<b>2-1</b>	<b>2-3</b>	<b>2-4</b>	<b>3-1</b>	<b>3-2</b>	<b>3-4</b>	<b>4-1</b>	<b>4-2</b>	<b>4-3</b>	<b>Zu. 1</b>	<b>Zu. 2</b>	<b>Zu. 3</b>	<b>Zu. 4</b>	<b>Ab. 1</b>	<b>Ab. 2</b>	<b>Ab. 3</b>	<b>Ab. 4</b>	<b>K-Sum</b>

**spezifische Spitzenstunde abends 16:15 Uhr - 17:15 Uhr**

FZ-ART	1-2	1-3	1-4	2-1	2-3	2-4	3-1	3-2	3-4	4-1	4-2	4-3	Zu. 1	Zu. 2	Zu. 3	Zu. 4	Ab. 1	Ab. 2	Ab. 3	Ab. 4	K-Sum
RAD	5	2	0	2	7	0	4	29	0	0	0	0	7	9	33	0	6	34	9	0	49
KRAD	4	9	0	2	9	0	5	7	0	0	0	0	13	11	12	0	7	11	18	0	36
PKW	199	211	0	227	418	0	258	217	0	0	0	0	410	645	475	0	485	416	629	0	1530
BUS	2	0	0	0	3	0	1	2	0	0	0	0	2	3	3	0	1	4	3	0	8
LFW	19	4	0	10	49	0	13	21	0	0	0	0	23	59	34	0	23	40			



# Stadt Dachau

Zählstelle: K24 Schleißheimer Straße / Kopernikusstraße

Zusammenfassung Stundengruppen

Zähltag: Do., 26.10.2006

Zu-/Ablauf 1: Kopernikusstr.

Zu-/Ablauf 2: Schleißheimer Str. (von/nach Stadtauswärts)

Zu-/Ablauf 3: Schleißheimer Str. (von/nach Stadteinwärts)

Spezifische Spitzenstunde morgens  
07:15 Uhr - 08:15 Uhr in KFZ

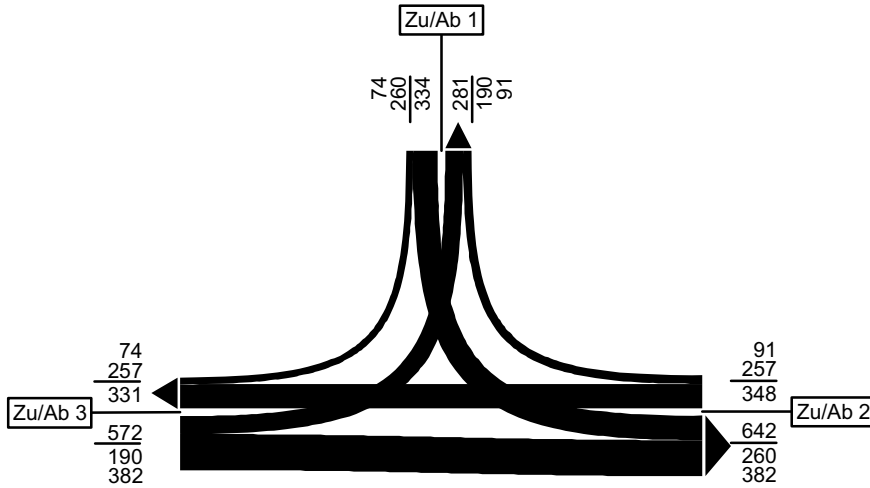

Spezifische Spitzenstunde abends  
16:15 Uhr - 17:15 Uhr in KFZ

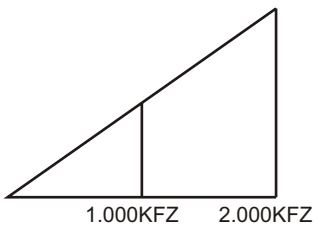
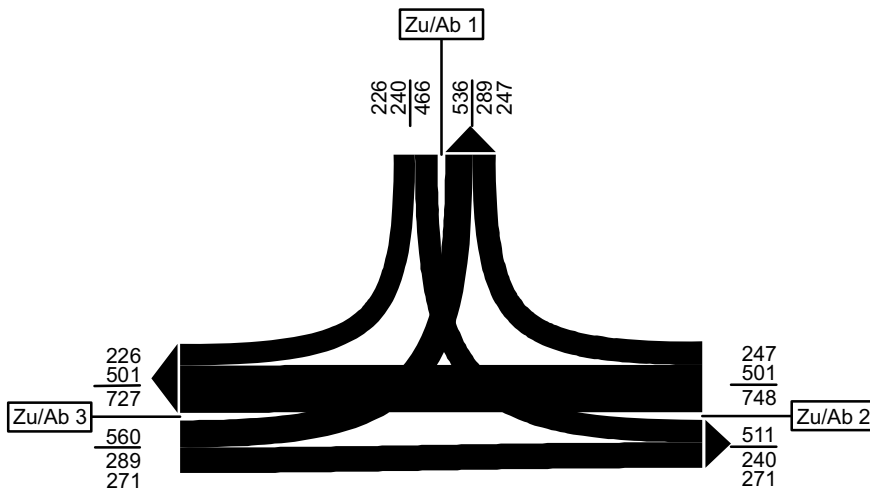

**Stadt Dachau**

Zählstelle: K25 Alte Römerstraße / Sudetenlandstraße

Zu-/Ablauf 1: Alte Römerstr. (von/nach Stadtauswärts)

Zu-/Ablauf 2: Fraunhoferstr.

Zu-/Ablauf 3: Alte Römerstr. (von/nach München)

Zu-/Ablauf 4: Sudetenlandstr.

Zusammenfassung Stundengruppen

Zähltag: Do., 26.04.2007

Zählzeit: 06:00 Uhr - 10:00 Uhr und 15:00 Uhr - 19:00 Uhr

**Summe Zählzeit (06:00 Uhr - 10:00 Uhr und 15:00 Uhr - 19:00 Uhr)**

FZ-ART	1-2	1-3	1-4	2-1	2-3	2-4	3-1	3-2	3-4	4-1	4-2	4-3	Zu. 1	Zu. 2	Zu. 3	Zu. 4	Ab. 1	Ab. 2	Ab. 3	Ab. 4	K-Sum
RAD	2	13	97	23	22	190	46	2	22	91	237	13	112	235	70	341	160	241	48	309	758
KRAD	9	99	60	11	8	42	104	6	29	50	56	5	168	61	139	111	165	71	112	131	479
PKW	726	2542	1334	375	763	1451	2396	752	1348	1321	2176	661	4602	2589	4496	4158	4092	3654	3966	4133	15845
BUS	24	12	26	25	0	1	20	0	1	28	1	1	62	26	21	30	73	25	13	28	139
LFW	32	237	86	13	22	35	164	34	50	84	56	28	355	70	248	168	261	122	287	171	841
LKW	7	89	34	7	3	9	101	12	33	40	19	11	130	19	146	70	148	38	103	76	365
LZ	0	144	13	4	5	3	131	5	7	18	7	17	157	12	143	42	153	12	166	23	354
<b>KFZ</b>	<b>798</b>	<b>3123</b>	<b>1553</b>	<b>435</b>	<b>801</b>	<b>1541</b>	<b>2916</b>	<b>809</b>	<b>1468</b>	<b>1541</b>	<b>2315</b>	<b>723</b>	<b>5474</b>	<b>2777</b>	<b>5193</b>	<b>4579</b>	<b>4892</b>	<b>3922</b>	<b>4647</b>	<b>4562</b>	<b>18023</b>
SV	31	245	73	36	8	13	252	17	41	86	27	29	349	57	310	142	374	75	282	127	858
PV	759	2653	1420	411	771	1494	2520	758	1378	1399	2233	667	4832	2676	4656	4299	4330	3750	4091	4292	16463
GV	39	470	133	24	30	47	396	51	90	142	82	56	642	101	537	280	562	172	556	270	1560
<b>FZ-ART</b>	<b>1-2</b>	<b>1-3</b>	<b>1-4</b>	<b>2-1</b>	<b>2-3</b>	<b>2-4</b>	<b>3-1</b>	<b>3-2</b>	<b>3-4</b>	<b>4-1</b>	<b>4-2</b>	<b>4-3</b>	<b>Zu. 1</b>	<b>Zu. 2</b>	<b>Zu. 3</b>	<b>Zu. 4</b>	<b>Ab. 1</b>	<b>Ab. 2</b>	<b>Ab. 3</b>	<b>Ab. 4</b>	<b>K-Sum</b>

**Summe Zählintervall 06:00 Uhr - 10:00 Uhr**

FZ-ART	1-2	1-3	1-4	2-1	2-3	2-4	3-1	3-2	3-4	4-1	4-2	4-3	Zu. 1	Zu. 2	Zu. 3	Zu. 4	Ab. 1	Ab. 2	Ab. 3	Ab. 4	K-Sum
RAD	0	1	28	6	2	34	20	2	1	60	105	4	29	42	23	169	86	107	7	63	263
KRAD	1	49	12	1	3	5	22	2	5	26	27	4	62	9	29	57	49	30	56	22	157
PKW	353	1340	496	84	215	355	826	251	316	626	1030	340	2189	654	1393	1996	1536	1634	1895	1167	6232
BUS	12	3	13	14	0	1	14	0	1	15	1	1	28	15	15	17	43	13	4	15	75
LFW	20	153	57	5	10	8	72	21	18	51	23	14	230	23	111	86	128	64	177	83	452
LKW	6	56	20	5	3	5	62	11	17	18	15	7	82	13	90	40	85	32	66	42	225
LZ	0	86	11	2	4	2	83	3	4	9	2	11	97	8	90	22	94	5	101	17	217
<b>KFZ</b>	<b>392</b>	<b>1687</b>	<b>609</b>	<b>111</b>	<b>235</b>	<b>376</b>	<b>1079</b>	<b>288</b>	<b>361</b>	<b>745</b>	<b>1098</b>	<b>377</b>	<b>2688</b>	<b>722</b>	<b>1728</b>	<b>2220</b>	<b>1935</b>	<b>1778</b>	<b>2299</b>	<b>1346</b>	<b>7358</b>
SV	18	145	44	21	7	8	159	14	22	42	18	19	207	36	195	79	222	50	171	74	517
PV	366	1392	521	99	218	361	862	253	322	667	1058	345	2279	678	1437	2070	1628	1677	1955	1204	6464
GV	26	295	88	12	17	15	217	35	39	78	40	32	409	44	291	150	307	101	344	142	894
<b>FZ-ART</b>	<b>1-2</b>	<b>1-3</b>	<b>1-4</b>	<b>2-1</b>	<b>2-3</b>	<b>2-4</b>	<b>3-1</b>	<b>3-2</b>	<b>3-4</b>	<b>4-1</b>	<b>4-2</b>	<b>4-3</b>	<b>Zu. 1</b>	<b>Zu. 2</b>	<b>Zu. 3</b>	<b>Zu. 4</b>	<b>Ab. 1</b>	<b>Ab. 2</b>	<b>Ab. 3</b>	<b>Ab. 4</b>	<b>K-Sum</b>

**Summe Zählintervall 15:00 Uhr - 19:00 Uhr**

FZ-ART	1-2	1-3	1-4	2-1	2-3	2-4	3-1	3-2	3-4	4-1	4-2	4-3	Zu. 1	Zu. 2	Zu. 3	Zu. 4	Ab. 1	Ab. 2	Ab. 3	Ab. 4	K-Sum
RAD	2	12	69	17	20	156	26	0	21	31	132	9	83	193	47	172	74	134	41	246	495
KRAD	8	50	48	10	5	37	82	4	24	24	29	1	106	52	110	54	116	41	56	109	322
PKW	373	1202	838	291	548	1096	1570	501	1032	695	1146	321	2413	1935	3103	2162	2556	2020	2071	2966	9613
BUS	12	9	13	11	0	0	6	0	0	13	0	0	34	11	6	13	30	12	9	13	64
LFW	12	84	29	8	12	27	92	13	32	33	33	14	125	47	137	80	133	58	110	88	389
LKW	1	33	14	2	0	4	39	1	16	22	4	4	48	6	56	30	63	6	37	34	140
LZ	0	58	2	2	1	1	48	2	3	9	5	6	60	4	53	20	59	7	65	6	137
<b>KFZ</b>	<b>406</b>	<b>1436</b>	<b>944</b>	<b>324</b>	<b>566</b>	<b>1165</b>	<b>1837</b>	<b>521</b>	<b>1107</b>	<b>796</b>	<b>1217</b>	<b>346</b>	<b>2786</b>	<b>2055</b>	<b>3465</b>	<b>2359</b>	<b>2957</b>	<b>2144</b>	<b>2348</b>	<b>3216</b>	<b>10665</b>
SV	13	100	29	15	1	5	93	3	19	44	9	10	142	21	115	63	152	25	111	53	341
PV	393	1261	899	312	553	1133	1658	505	1056	732	1175	322	2553	1998	3219	2229	2702	2073	2136	3088	9999
GV	13	175	45	12	13	32	179	16	51	64	42	24	233	57	246	130	255	71	212	128	666
<b>FZ-ART</b>	<b>1-2</b>	<b>1-3</b>	<b>1-4</b>	<b>2-1</b>	<b>2-3</b>	<b>2-4</b>	<b>3-1</b>	<b>3-2</b>	<b>3-4</b>	<b>4-1</b>	<b>4-2</b>	<b>4-3</b>	<b>Zu. 1</b>	<b>Zu. 2</b>	<b>Zu. 3</b>	<b>Zu. 4</b>	<b>Ab. 1</b>	<b>Ab. 2</b>	<b>Ab. 3</b>	<b>Ab. 4</b>	<b>K-Sum</b>

**spezifische Spitzenstunde morgens 08:45 Uhr - 09:45 Uhr**

FZ-ART	1-2	1-3	1-4	2-1	2-3	2-4	3-1	3-2	3-4	4-1	4-2	4-3	Zu. 1	Zu. 2	Zu. 3	Zu. 4	Ab. 1	Ab. 2	Ab. 3	Ab. 4	K-Sum
RAD	0	0	9	1	2	14	9	0	0	25	44	1	9	17	9	70	35	44	3	23	105
KRAD	0	5	4	1	1	2	6	0	1	3	8	1	9	4	7	12	10	8	7	7	32
PKW	121	290	111	35	102	161	241	123	146	153	338	98	522	298	510	589	429	582	490	418	1919
BUS	3	1	3	3	0	0	11	0	1	3	0	0	7	3	12	3	17	3	1	4	25
LFW	8	35	16	3	4	2	18	7	7	12	6	4	59	9	32	22	33	21	43	25	122
LKW	3	24	6	3	1	2	24	3	4	8	4	3	33	6	31	15	35	10	28	12	85
LZ	0	15	2	1	1	0	24	0	1	5	0	2	17	2	25	7	30	0	18	3	51
<b>KFZ</b>	<b>135</b>	<b>370</b>	<b>142</b>	<b>46</b>	<b>109</b>	<b>167</b>	<b>324</b>	<b>133</b>	<b>160</b>	<b>184</b>	<b>356</b>	<b>108</b>	<b>647</b>	<b>322</b>	<b>617</b>	<b>648</b>	<b>554</b>	<b>624</b>	<b>587</b>	<b>469</b>	<b>2234</b>
SV	6	40	11	7	2	2	59	3	6	16	4	5	57	11	68	25	82	13	47	19	161
PV	124	296	118	39	103	163	258	123	148	159	346	99	538	305	529	604	456	593	498	429	1976
GV	11	74	24	7	6	4	66	10	12	25	10	9	109	17	88	44	98	31	89	40	258
<b>FZ-ART</b>	<b>1-2</b>	<b>1-3</b>	<b>1-4</b>	<b>2-1</b>	<b>2-3</b>	<b>2-4</b>	<b>3-1</b>	<b>3-2</b>	<b>3-4</b>	<b>4-1</b>	<b>4-2</b>	<b>4-3</b>	<b>Zu. 1</b>	<b>Zu. 2</b>	<b>Zu. 3</b>	<b>Zu. 4</b>	<b>Ab. 1</b>	<b>Ab. 2</b>	<b>Ab. 3</b>	<b>Ab. 4</b>	<b>K-Sum</b>

**spezifische Spitzenstunde abends 16:45 Uhr - 17:45 Uhr**

FZ-ART	1-2	1-3	1-4	2-1	2-3	2-4	3-1	3-2	3-4	4-1	4-2	4-3	Zu. 1	Zu. 2	Zu. 3	Zu. 4	Ab. 1	Ab. 2	Ab. 3	Ab. 4	K-Sum
RAD	0	5	19	2	7	44	3	0	5	8	38	0	24	53	8	46	13	38	12	68	131
KRAD	3	13	18	3	2	10	21	1	5	5	10	1	34	15	27	16	29	14	16	33	92
PKW	88	352	261	85																	

# Stadt Dachau

Zählstelle: K25 Alte Römerstraße / Sudetenlandstraße

Zusammenfassung Stundengruppen

Zähltag: Do., 26.04.2007

Zu-/Ablauf 1: Alte Römerstr. (von/nach Stadtauswärts)

Zu-/Ablauf 2: Fraunhoferstr.

Zu-/Ablauf 3: Alte Römerstr. (von/nach München)

Zu-/Ablauf 4: Sudetenlandstr.

Spezifische Spitzenstunde morgens  
08:45 Uhr - 09:45 Uhr in KFZ

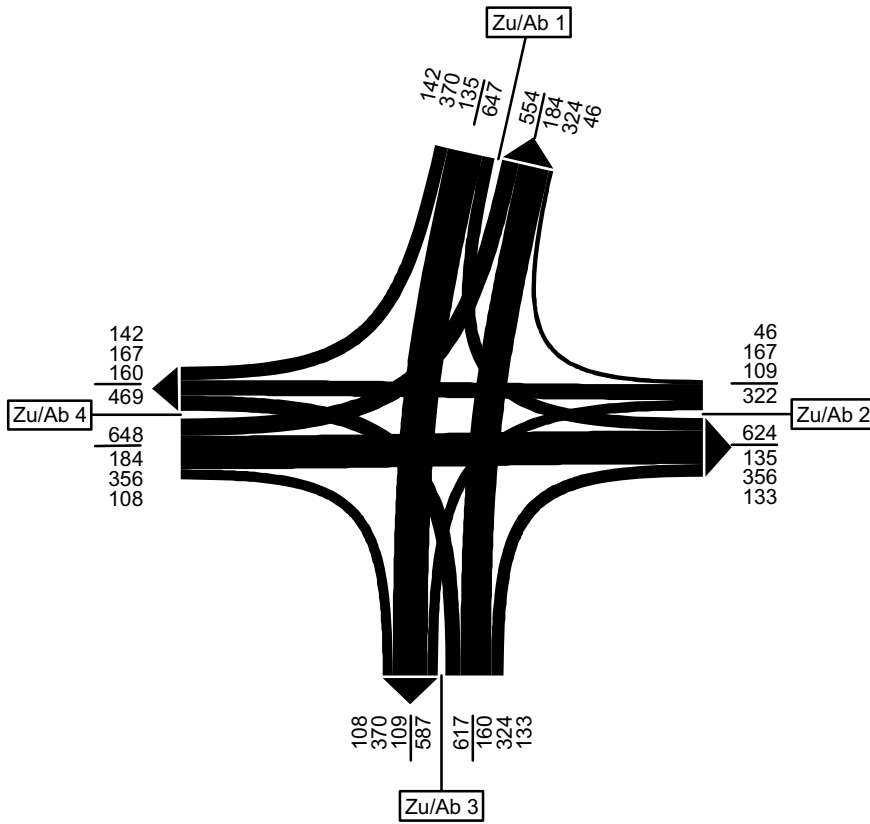

Spezifische Spitzenstunde abends  
16:45 Uhr - 17:45 Uhr in KFZ

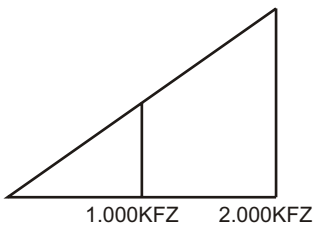
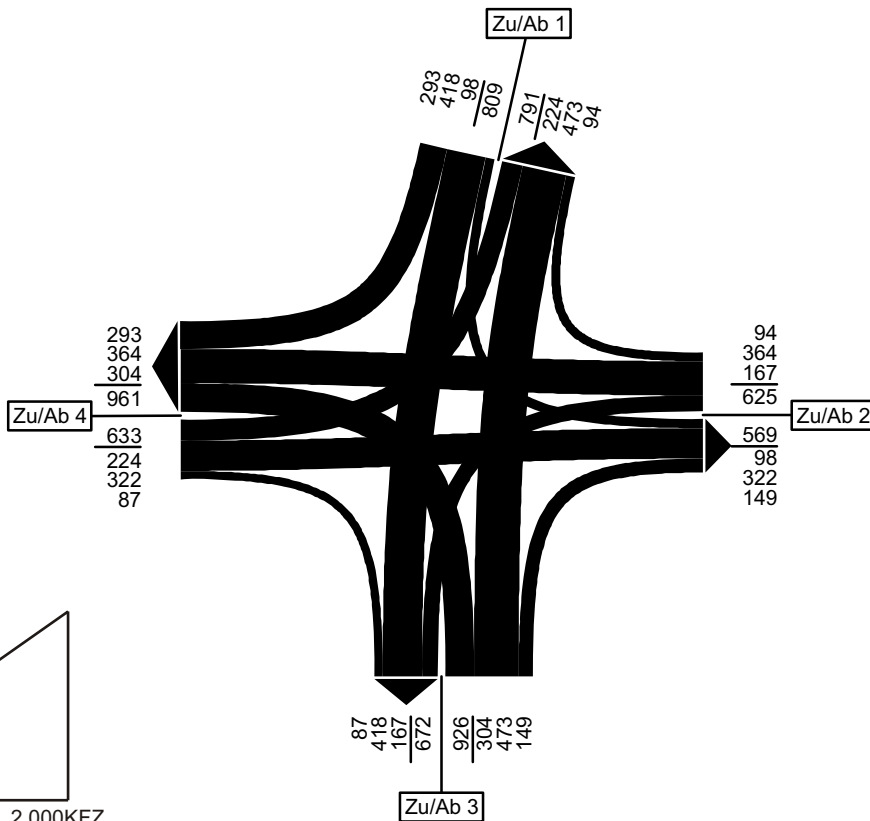

# Stadt Dachau

Zählstelle: K26 Alte Römerstraße / Rudolf-Diesel-Straße

Zu-/Ablauf 1: Alte Römerstr. (von/nach Stadtauswärts)

Zu-/Ablauf 2: Rudolf-Diesel-Str.

Zu-/Ablauf 3: Alte Römerstr. (von/nach München)

Zusammenfassung Stundengruppen

Zähltag: Do., 26.04.2007

Zählzeit: 06:00 Uhr - 10:00 Uhr und 15:00 Uhr - 19:00 Uhr

## Summe Zählzeit (06:00 Uhr - 10:00 Uhr und 15:00 Uhr - 19:00 Uhr)

FZ-ART	1-2	1-3	1-4	2-1	2-3	2-4	3-1	3-2	3-4	4-1	4-2	4-3	Zu. 1	Zu. 2	Zu. 3	Zu. 4	Ab. 1	Ab. 2	Ab. 3	Ab. 4	K-Sum
RAD	1	140	0	0	0	0	94	13	0	0	0	0	141	0	107	0	94	14	140	0	248
KRAD	11	178	0	0	0	0	157	16	0	0	0	0	189	0	173	0	157	27	178	0	362
PKW	384	4587	0	0	0	0	3708	386	0	0	0	0	4971	0	4094	0	3708	770	4587	0	9065
BUS	3	65	0	0	0	0	70	2	0	0	0	0	68	0	72	0	70	5	65	0	140
LFW	16	388	0	0	0	0	178	27	0	0	0	0	404	0	205	0	178	43	388	0	609
LKW	9	190	0	0	0	0	141	24	0	0	0	0	199	0	165	0	141	33	190	0	364
LZ	1	179	0	0	0	0	126	10	0	0	0	0	180	0	136	0	126	11	179	0	316
<b>KFZ</b>	<b>424</b>	<b>5587</b>	<b>0</b>	<b>0</b>	<b>0</b>	<b>0</b>	<b>4380</b>	<b>465</b>	<b>0</b>	<b>0</b>	<b>0</b>	<b>0</b>	<b>6011</b>	<b>0</b>	<b>4845</b>	<b>0</b>	<b>4380</b>	<b>889</b>	<b>5587</b>	<b>0</b>	<b>10856</b>
SV	13	434	0	0	0	0	337	36	0	0	0	0	447	0	373	0	337	49	434	0	820
PV	398	4830	0	0	0	0	3935	404	0	0	0	0	5228	0	4339	0	3935	802	4830	0	9567
GV	26	757	0	0	0	0	445	61	0	0	0	0	783	0	506	0	445	87	757	0	1299
<b>FZ-ART</b>	<b>1-2</b>	<b>1-3</b>	<b>1-4</b>	<b>2-1</b>	<b>2-3</b>	<b>2-4</b>	<b>3-1</b>	<b>3-2</b>	<b>3-4</b>	<b>4-1</b>	<b>4-2</b>	<b>4-3</b>	<b>Zu. 1</b>	<b>Zu. 2</b>	<b>Zu. 3</b>	<b>Zu. 4</b>	<b>Ab. 1</b>	<b>Ab. 2</b>	<b>Ab. 3</b>	<b>Ab. 4</b>	<b>K-Sum</b>

## Summe Zählintervall 06:00 Uhr - 10:00 Uhr

FZ-ART	1-2	1-3	1-4	2-1	2-3	2-4	3-1	3-2	3-4	4-1	4-2	4-3	Zu. 1	Zu. 2	Zu. 3	Zu. 4	Ab. 1	Ab. 2	Ab. 3	Ab. 4	K-Sum
RAD	1	31	0	0	0	0	39	6	0	0	0	0	32	0	45	0	39	7	31	0	77
KRAD	9	68	0	0	0	0	45	4	0	0	0	0	77	0	49	0	45	13	68	0	126
PKW	248	2193	0	0	0	0	1382	178	0	0	0	0	2441	0	1560	0	1382	426	2193	0	4001
BUS	2	30	0	0	0	0	40	2	0	0	0	0	32	0	42	0	40	4	30	0	74
LFW	15	254	0	0	0	0	96	14	0	0	0	0	269	0	110	0	96	29	254	0	379
LKW	4	120	0	0	0	0	94	12	0	0	0	0	124	0	106	0	94	16	120	0	230
LZ	0	114	0	0	0	0	62	6	0	0	0	0	114	0	68	0	62	6	114	0	182
<b>KFZ</b>	<b>278</b>	<b>2779</b>	<b>0</b>	<b>0</b>	<b>0</b>	<b>0</b>	<b>1719</b>	<b>216</b>	<b>0</b>	<b>0</b>	<b>0</b>	<b>0</b>	<b>3057</b>	<b>0</b>	<b>1935</b>	<b>0</b>	<b>1719</b>	<b>494</b>	<b>2779</b>	<b>0</b>	<b>4992</b>
SV	6	264	0	0	0	0	196	20	0	0	0	0	270	0	216	0	196	26	264	0	486
PV	259	2291	0	0	0	0	1467	184	0	0	0	0	2550	0	1651	0	1467	443	2291	0	4201
GV	19	488	0	0	0	0	252	32	0	0	0	0	507	0	284	0	252	51	488	0	791
<b>FZ-ART</b>	<b>1-2</b>	<b>1-3</b>	<b>1-4</b>	<b>2-1</b>	<b>2-3</b>	<b>2-4</b>	<b>3-1</b>	<b>3-2</b>	<b>3-4</b>	<b>4-1</b>	<b>4-2</b>	<b>4-3</b>	<b>Zu. 1</b>	<b>Zu. 2</b>	<b>Zu. 3</b>	<b>Zu. 4</b>	<b>Ab. 1</b>	<b>Ab. 2</b>	<b>Ab. 3</b>	<b>Ab. 4</b>	<b>K-Sum</b>

## Summe Zählintervall 15:00 Uhr - 19:00 Uhr

FZ-ART	1-2	1-3	1-4	2-1	2-3	2-4	3-1	3-2	3-4	4-1	4-2	4-3	Zu. 1	Zu. 2	Zu. 3	Zu. 4	Ab. 1	Ab. 2	Ab. 3	Ab. 4	K-Sum
RAD	0	109	0	0	0	0	55	7	0	0	0	0	109	0	62	0	55	7	109	0	171
KRAD	2	110	0	0	0	0	112	12	0	0	0	0	112	0	124	0	112	14	110	0	236
PKW	136	2394	0	0	0	0	2326	208	0	0	0	0	2530	0	2534	0	2326	344	2394	0	5064
BUS	1	35	0	0	0	0	30	0	0	0	0	0	36	0	30	0	30	1	35	0	66
LFW	1	134	0	0	0	0	82	13	0	0	0	0	135	0	95	0	82	14	134	0	230
LKW	5	70	0	0	0	0	47	12	0	0	0	0	75	0	59	0	47	17	70	0	134
LZ	1	65	0	0	0	0	64	4	0	0	0	0	66	0	68	0	64	5	65	0	134
<b>KFZ</b>	<b>146</b>	<b>2808</b>	<b>0</b>	<b>0</b>	<b>0</b>	<b>0</b>	<b>2661</b>	<b>249</b>	<b>0</b>	<b>0</b>	<b>0</b>	<b>0</b>	<b>2954</b>	<b>0</b>	<b>2910</b>	<b>0</b>	<b>2661</b>	<b>395</b>	<b>2808</b>	<b>0</b>	<b>5864</b>
SV	7	170	0	0	0	0	141	16	0	0	0	0	177	0	157	0	141	23	170	0	334
PV	139	2539	0	0	0	0	2468	220	0	0	0	0	2678	0	2688	0	2468	359	2539	0	5366
GV	7	269	0	0	0	0	193	29	0	0	0	0	276	0	222	0	193	36	269	0	498
<b>FZ-ART</b>	<b>1-2</b>	<b>1-3</b>	<b>1-4</b>	<b>2-1</b>	<b>2-3</b>	<b>2-4</b>	<b>3-1</b>	<b>3-2</b>	<b>3-4</b>	<b>4-1</b>	<b>4-2</b>	<b>4-3</b>	<b>Zu. 1</b>	<b>Zu. 2</b>	<b>Zu. 3</b>	<b>Zu. 4</b>	<b>Ab. 1</b>	<b>Ab. 2</b>	<b>Ab. 3</b>	<b>Ab. 4</b>	<b>K-Sum</b>

## spezifische Spitzenstunde morgens 07:15 Uhr - 08:15 Uhr

FZ-ART	1-2	1-3	1-4	2-1	2-3	2-4	3-1	3-2	3-4	4-1	4-2	4-3	Zu. 1	Zu. 2	Zu. 3	Zu. 4	Ab. 1	Ab. 2	Ab. 3	Ab. 4	K-Sum
RAD	0	10	0	0	0	0	12	2	0	0	0	0	10	0	14	0	12	2	10	0	24
KRAD	3	25	0	0	0	0	13	1	0	0	0	0	28	0	14	0	13	4	25	0	42
PKW	97	652	0	0	0	0	402	53	0	0	0	0	749	0	455	0	402	150	652	0	1204
BUS	1	7	0	0	0	0	8	1	0	0	0	0	8	0	9	0	8	2	7	0	17
LFW	7	86	0	0	0	0	27	4	0	0	0	0	93	0	31	0	27	11	86	0	124
LKW	0	28	0	0	0	0	25	5	0	0	0	0	28	0	30	0	25	5	28	0	58
LZ	0	36	0	0	0	0	13	3	0	0	0	0	36	0	16	0	13	3	36	0	52
<b>KFZ</b>	<b>108</b>	<b>834</b>	<b>0</b>	<b>0</b>	<b>0</b>	<b>0</b>	<b>488</b>	<b>67</b>	<b>0</b>	<b>0</b>	<b>0</b>	<b>0</b>	<b>942</b>	<b>0</b>	<b>555</b>	<b>0</b>	<b>488</b>	<b>175</b>	<b>834</b>	<b>0</b>	<b>1497</b>
SV	1	71	0	0	0	0	46	9	0	0	0	0	72	0	55	0	46	10	71	0	127
PV	101	684	0	0	0	0	423	55	0	0	0	0	785	0	478	0	423	156	684	0	1263
GV	7	150	0	0	0	0	65	12	0	0	0	0	157	0	77	0	65	19	150	0	234
<b>FZ-ART</b>	<b>1-2</b>	<b>1-3</b>	<b>1-4</b>	<b>2-1</b>	<b>2-3</b>	<b>2-4</b>	<b>3-1</b>	<b>3-2</b>	<b>3-4</b>	<b>4-1</b>	<b>4-2</b>	<b>4-3</b>	<b>Zu. 1</b>	<b>Zu. 2</b>	<b>Zu. 3</b>	<b>Zu. 4</b>	<b>Ab. 1</b>	<b>Ab. 2</b>	<b>Ab. 3</b>	<b>Ab. 4</b>	<b>K-Sum</b>

## spezifische Spitzenstunde abends 16:30 Uhr - 17:30 Uhr

FZ-ART	1-2	1-3	1-4	2-1	2-3	2-4	3-1	3-2	3-4	4-1	4-2	4-3	Zu. 1	Zu. 2	Zu. 3	Zu. 4	Ab. 1	Ab. 2	Ab. 3	Ab. 4	K-Sum
RAD	0	28	0	0	0	0	7	2	0	0	0	0	28	0	9	0	7	2	28	0	37
KRAD	1	34	0	0	0	0	32	2	0	0	0	0	35	0	34	0	32	3	34	0	69
PKW	39	726	0	0	0	0	611	59	0	0	0	0	765	0	670	0	611	98	726	0	1435
BUS	0	10	0	0	0	0	7	0	0	0	0	0	10	0	7	0	7	0	10	0	17
LFW	0	38	0	0	0	0	22	5	0	0	0	0	38	0	27	0	22	5	38	0	65
LKW	2	19	0	0	0	0	12	3	0	0	0	0	21	0	15	0	12	5	19	0	

# Stadt Dachau

Zählstelle: K26 Alte Römerstraße / Rudolf-Diesel-Straße

Zusammenfassung Stundengruppen

Zähltag: Do., 26.04.2007

Zu-/Ablauf 1: Alte Römerstr. (von/nach Stadtauswärts)

Zu-/Ablauf 2: Rudolf-Diesel-Str.

Zu-/Ablauf 3: Alte Römerstr. (von/nach München)

Spezifische Spitzenstunde morgens  
07:15 Uhr - 08:15 Uhr in KFZ

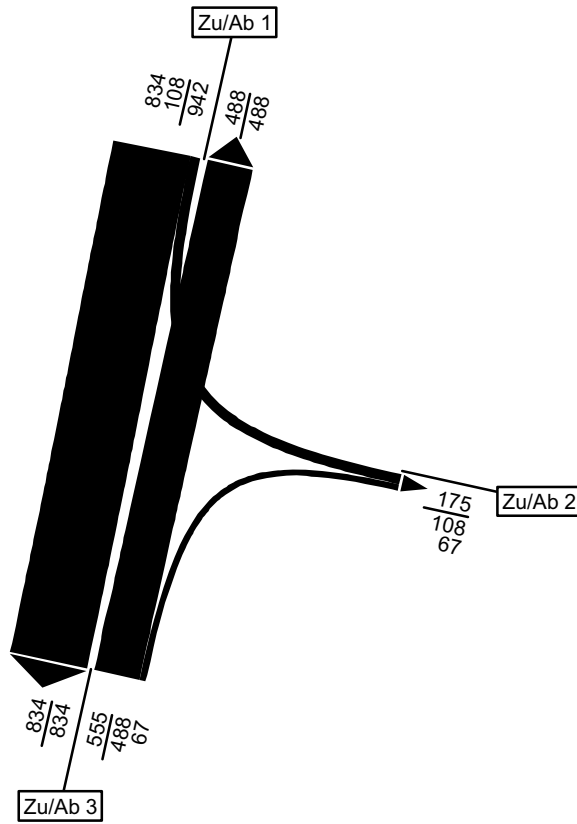

Spezifische Spitzenstunde abends  
16:30 Uhr - 17:30 Uhr in KFZ

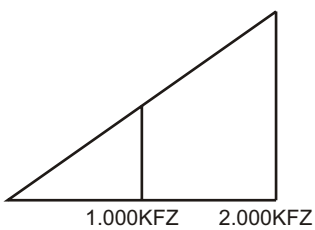
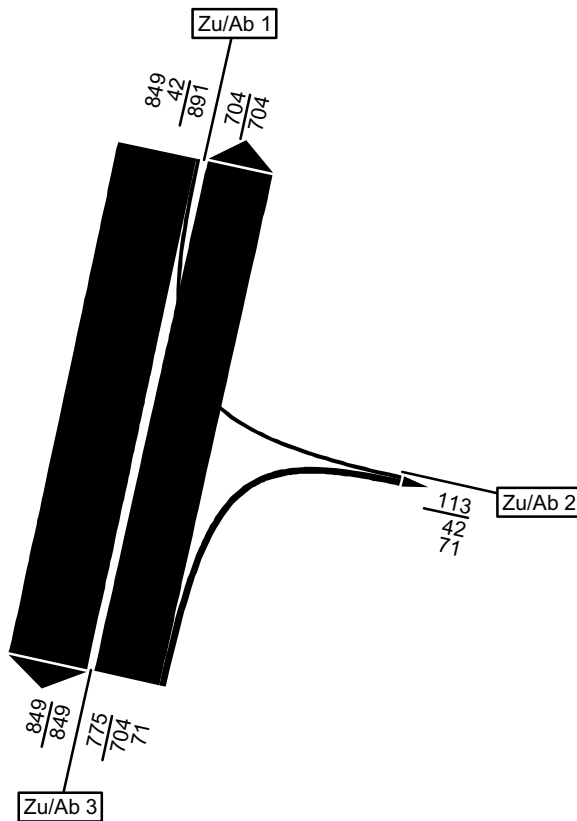

# Stadt Dachau

Zählstelle: K27 Alte Römerstraße / Pater-Roth-Straße

Zu-/Ablauf 1: Alte Römerstr. (von/nach Stadtauswärts)

Zu-/Ablauf 2: Alte Römerstr. (von/nach München)

Zu-/Ablauf 3: Pater-Roth-Str.

Zusammenfassung Stundengruppen

Zähltag: Do., 26.04.2007

Zählzeit: 06:00 Uhr - 10:00 Uhr und 15:00 Uhr - 19:00 Uhr

## Summe Zählzeit (06:00 Uhr - 10:00 Uhr und 15:00 Uhr - 19:00 Uhr)

FZ-ART	1-2	1-3	1-4	2-1	2-3	2-4	3-1	3-2	3-4	4-1	4-2	4-3	Zu. 1	Zu. 2	Zu. 3	Zu. 4	Ab. 1	Ab. 2	Ab. 3	Ab. 4	K-Sum
RAD	45	29	0	54	30	0	27	41	0	0	0	0	74	84	68	0	81	86	59	0	226
KRAD	116	12	0	136	14	0	15	21	0	0	0	0	128	150	36	0	151	137	26	0	314
PKW	3760	130	0	3486	233	0	117	298	0	0	0	0	3890	3719	415	0	3603	4058	363	0	8024
BUS	6	1	0	7	26	0	2	25	0	0	0	0	7	33	27	0	9	31	27	0	67
LFW	154	6	0	194	7	0	6	7	0	0	0	0	160	201	13	0	200	161	13	0	374
LKW	126	3	0	111	4	0	4	3	0	0	0	0	129	115	7	0	115	129	7	0	251
LZ	20	0	0	43	5	0	0	2	0	0	0	0	20	48	2	0	43	22	5	0	70
<b>KFZ</b>	<b>4182</b>	<b>152</b>	<b>0</b>	<b>3977</b>	<b>289</b>	<b>0</b>	<b>144</b>	<b>356</b>	<b>0</b>	<b>0</b>	<b>0</b>	<b>0</b>	<b>4334</b>	<b>4266</b>	<b>500</b>	<b>0</b>	<b>4121</b>	<b>4538</b>	<b>441</b>	<b>0</b>	<b>9100</b>
SV	152	4	0	161	35	0	6	30	0	0	0	0	156	196	36	0	167	182	39	0	388
PV	3882	143	0	3629	273	0	134	344	0	0	0	0	4025	3902	478	0	3763	4226	416	0	8405
GV	300	9	0	348	16	0	10	12	0	0	0	0	309	364	22	0	358	312	25	0	695
<b>FZ-ART</b>	<b>1-2</b>	<b>1-3</b>	<b>1-4</b>	<b>2-1</b>	<b>2-3</b>	<b>2-4</b>	<b>3-1</b>	<b>3-2</b>	<b>3-4</b>	<b>4-1</b>	<b>4-2</b>	<b>4-3</b>	<b>Zu. 1</b>	<b>Zu. 2</b>	<b>Zu. 3</b>	<b>Zu. 4</b>	<b>Ab. 1</b>	<b>Ab. 2</b>	<b>Ab. 3</b>	<b>Ab. 4</b>	<b>K-Sum</b>

## Summe Zählintervall 06:00 Uhr - 10:00 Uhr

FZ-ART	1-2	1-3	1-4	2-1	2-3	2-4	3-1	3-2	3-4	4-1	4-2	4-3	Zu. 1	Zu. 2	Zu. 3	Zu. 4	Ab. 1	Ab. 2	Ab. 3	Ab. 4	K-Sum
RAD	13	8	0	8	4	0	16	13	0	0	0	0	21	12	29	0	24	26	12	0	62
KRAD	68	4	0	24	0	0	2	11	0	0	0	0	72	24	13	0	26	79	4	0	109
PKW	2242	70	0	852	53	0	42	128	0	0	0	0	2312	905	170	0	894	2370	123	0	3387
BUS	3	1	0	4	14	0	2	13	0	0	0	0	4	18	15	0	6	16	15	0	37
LFW	114	5	0	80	4	0	3	4	0	0	0	0	119	84	7	0	83	118	9	0	210
LKW	80	2	0	63	3	0	2	3	0	0	0	0	82	66	5	0	65	83	5	0	153
LZ	10	0	0	24	4	0	0	1	0	0	0	0	10	28	1	0	24	11	4	0	39
<b>KFZ</b>	<b>2517</b>	<b>82</b>	<b>0</b>	<b>1047</b>	<b>78</b>	<b>0</b>	<b>51</b>	<b>160</b>	<b>0</b>	<b>0</b>	<b>0</b>	<b>0</b>	<b>2599</b>	<b>1125</b>	<b>211</b>	<b>0</b>	<b>1098</b>	<b>2677</b>	<b>160</b>	<b>0</b>	<b>3935</b>
SV	93	3	0	91	21	0	4	17	0	0	0	0	96	112	21	0	95	110	24	0	229
PV	2313	75	0	880	67	0	46	152	0	0	0	0	2388	947	198	0	926	2465	142	0	3533
GV	204	7	0	167	11	0	5	8	0	0	0	0	211	178	13	0	172	212	18	0	402
<b>FZ-ART</b>	<b>1-2</b>	<b>1-3</b>	<b>1-4</b>	<b>2-1</b>	<b>2-3</b>	<b>2-4</b>	<b>3-1</b>	<b>3-2</b>	<b>3-4</b>	<b>4-1</b>	<b>4-2</b>	<b>4-3</b>	<b>Zu. 1</b>	<b>Zu. 2</b>	<b>Zu. 3</b>	<b>Zu. 4</b>	<b>Ab. 1</b>	<b>Ab. 2</b>	<b>Ab. 3</b>	<b>Ab. 4</b>	<b>K-Sum</b>

## Summe Zählintervall 15:00 Uhr - 19:00 Uhr

FZ-ART	1-2	1-3	1-4	2-1	2-3	2-4	3-1	3-2	3-4	4-1	4-2	4-3	Zu. 1	Zu. 2	Zu. 3	Zu. 4	Ab. 1	Ab. 2	Ab. 3	Ab. 4	K-Sum
RAD	32	21	0	46	26	0	11	28	0	0	0	0	53	72	39	0	57	60	47	0	164
KRAD	48	8	0	112	14	0	13	10	0	0	0	0	56	126	23	0	125	58	22	0	205
PKW	1518	60	0	2634	180	0	75	170	0	0	0	0	1578	2814	245	0	2709	1688	240	0	4637
BUS	3	0	0	3	12	0	0	12	0	0	0	0	3	15	12	0	3	15	12	0	30
LFW	40	1	0	114	3	0	3	3	0	0	0	0	41	117	6	0	117	43	4	0	164
LKW	46	1	0	48	1	0	2	0	0	0	0	0	47	49	2	0	50	46	2	0	98
LZ	10	0	0	19	1	0	0	1	0	0	0	0	10	20	1	0	19	11	1	0	31
<b>KFZ</b>	<b>1665</b>	<b>70</b>	<b>0</b>	<b>2930</b>	<b>211</b>	<b>0</b>	<b>93</b>	<b>196</b>	<b>0</b>	<b>0</b>	<b>0</b>	<b>0</b>	<b>1735</b>	<b>3141</b>	<b>289</b>	<b>0</b>	<b>3023</b>	<b>1861</b>	<b>281</b>	<b>0</b>	<b>5165</b>
SV	59	1	0	70	14	0	2	13	0	0	0	0	60	84	15	0	72	72	15	0	159
PV	1569	68	0	2749	206	0	88	192	0	0	0	0	1637	2955	280	0	2837	1761	274	0	4872
GV	96	2	0	181	5	0	5	4	0	0	0	0	98	186	9	0	186	100	7	0	293
<b>FZ-ART</b>	<b>1-2</b>	<b>1-3</b>	<b>1-4</b>	<b>2-1</b>	<b>2-3</b>	<b>2-4</b>	<b>3-1</b>	<b>3-2</b>	<b>3-4</b>	<b>4-1</b>	<b>4-2</b>	<b>4-3</b>	<b>Zu. 1</b>	<b>Zu. 2</b>	<b>Zu. 3</b>	<b>Zu. 4</b>	<b>Ab. 1</b>	<b>Ab. 2</b>	<b>Ab. 3</b>	<b>Ab. 4</b>	<b>K-Sum</b>

## spezifische Spitzenstunde morgens 07:15 Uhr - 08:15 Uhr

FZ-ART	1-2	1-3	1-4	2-1	2-3	2-4	3-1	3-2	3-4	4-1	4-2	4-3	Zu. 1	Zu. 2	Zu. 3	Zu. 4	Ab. 1	Ab. 2	Ab. 3	Ab. 4	K-Sum
RAD	3	7	0	0	1	0	4	2	0	0	0	0	10	1	6	0	4	5	8	0	17
KRAD	26	1	0	9	0	0	1	4	0	0	0	0	27	9	5	0	10	30	1	0	41
PKW	744	32	0	231	13	0	2	51	0	0	0	0	776	244	53	0	233	795	45	0	1073
BUS	1	0	0	2	4	0	0	3	0	0	0	0	1	6	3	0	2	4	4	0	10
LFW	40	2	0	22	3	0	1	2	0	0	0	0	42	25	3	0	23	42	5	0	70
LKW	8	1	0	15	0	0	0	0	0	0	0	0	9	15	0	0	15	8	1	0	24
LZ	2	0	0	4	1	0	0	0	0	0	0	0	2	5	0	0	4	2	1	0	7
<b>KFZ</b>	<b>821</b>	<b>36</b>	<b>0</b>	<b>283</b>	<b>21</b>	<b>0</b>	<b>4</b>	<b>60</b>	<b>0</b>	<b>0</b>	<b>0</b>	<b>0</b>	<b>857</b>	<b>304</b>	<b>64</b>	<b>0</b>	<b>287</b>	<b>881</b>	<b>57</b>	<b>0</b>	<b>1225</b>
SV	11	1	0	21	5	0	0	3	0	0	0	0	12	26	3	0	21	14	6	0	41
PV	771	33	0	242	17	0	3	58	0	0	0	0	804	259	61	0	245	829	50	0	1124
GV	50	3	0	41	4	0	1	2	0	0	0	0	53	45	3	0	42	52	7	0	101
<b>FZ-ART</b>	<b>1-2</b>	<b>1-3</b>	<b>1-4</b>	<b>2-1</b>	<b>2-3</b>	<b>2-4</b>	<b>3-1</b>	<b>3-2</b>	<b>3-4</b>	<b>4-1</b>	<b>4-2</b>	<b>4-3</b>	<b>Zu. 1</b>	<b>Zu. 2</b>	<b>Zu. 3</b>	<b>Zu. 4</b>	<b>Ab. 1</b>	<b>Ab. 2</b>	<b>Ab. 3</b>	<b>Ab. 4</b>	<b>K-Sum</b>

## spezifische Spitzenstunde abends 16:15 Uhr - 17:15 Uhr

FZ-ART	1-2	1-3	1-4	2-1	2-3	2-4	3-1	3-2	3-4	4-1	4-2	4-3	Zu. 1	Zu. 2	Zu. 3	Zu. 4	Ab. 1	Ab. 2	Ab. 3	Ab. 4	K-Sum
RAD	8	11	0	9	3	0	3	10	0	0	0	0	19	12	13	0	12	18	14	0	44
KRAD	13	4	0	37	3	0	4	4	0	0	0	0	17	40	8	0	41	17	7	0	65
PKW	466	20	0	747	48	0	24	52	0	0	0	0	486	795	76	0	771	518	68	0	1357
BUS	2	0	0	0	3	0	0	3	0	0	0	0	2	3	3	0	0	5	3	0	8
LFW	12	1	0	37	0	0	0	2	0	0	0	0	13	37	2	0	37	14	1	0	52
LKW	16	0	0	18	0	0	1	0	0	0	0	0	16	18	1	0	19	16	0	0	35

# Stadt Dachau

Zählstelle: K27 Alte Römerstraße / Pater-Roth-Straße

Zusammenfassung Stundengruppen

Zähltag: Do., 26.04.2007

Zu-/Ablauf 1: Alte Römerstr. (von/nach Stadtauswärts)

Zu-/Ablauf 2: Alte Römerstr. (von/nach München)

Zu-/Ablauf 3: Pater-Roth-Str.

Spezifische Spitzenstunde morgens  
07:15 Uhr - 08:15 Uhr in KFZ

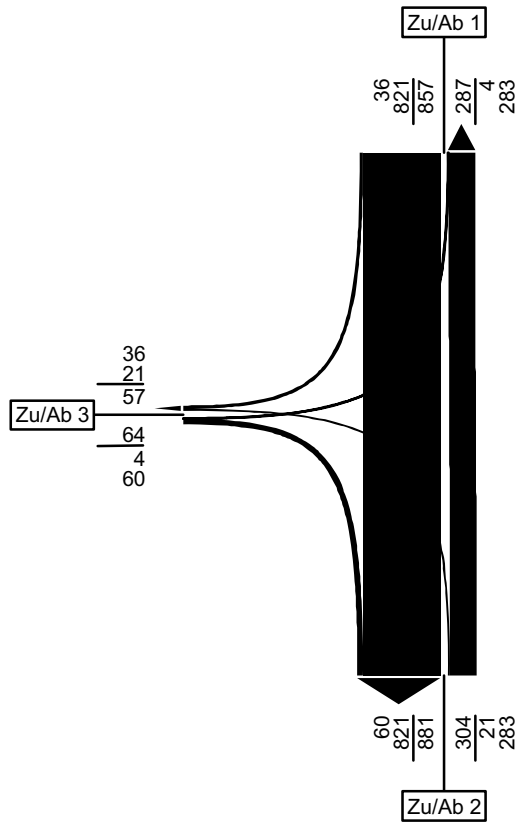

Spezifische Spitzenstunde abends  
16:15 Uhr - 17:15 Uhr in KFZ

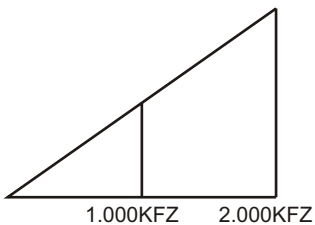
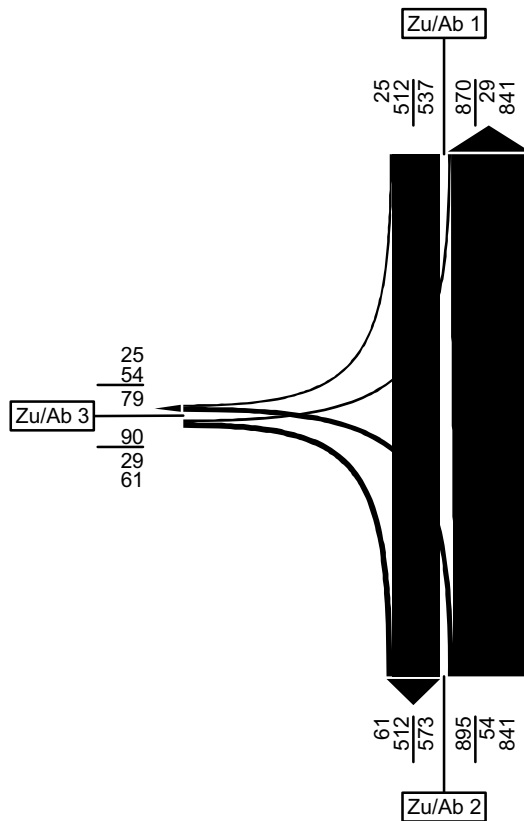

**Stadt Dachau**

Zählstelle: K28 ST2339 / Alte Römerstraße

Zu-/Ablauf 1: ST2339 (von/nach Freising)

Zu-/Ablauf 2: Alte Römerstr.

Zu-/Ablauf 3: ST2339 (von/nach Etzenhausen)

Zusammenfassung Stundengruppen

Zähltag: Do., 26.04.2007

Zählzeit: 06:00 Uhr - 10:00 Uhr und 15:00 Uhr - 19:00 Uhr

**Summe Zähizeit (06:00 Uhr - 10:00 Uhr und 15:00 Uhr - 19:00 Uhr)**

FZ-ART	1-2	1-3	1-4	2-1	2-3	2-4	3-1	3-2	3-4	4-1	4-2	4-3	Zu. 1	Zu. 2	Zu. 3	Zu. 4	Ab. 1	Ab. 2	Ab. 3	Ab. 4	K-Sum
RAD	26	25	0	31	7	0	20	25	0	0	0	0	51	38	45	0	51	51	32	0	134
KRAD	115	71	0	126	34	0	50	22	0	0	0	0	186	160	72	0	176	137	105	0	418
PKW	3184	1680	0	2982	621	0	1447	706	0	0	0	0	4864	3603	2153	0	4429	3890	2301	0	10620
BUS	15	8	0	8	3	0	8	3	0	0	0	0	23	11	11	0	16	18	11	0	45
LFW	213	102	0	175	31	0	89	45	0	0	0	0	315	206	134	0	264	258	133	0	655
LKW	75	64	0	104	38	0	59	13	0	0	0	0	139	142	72	0	163	88	102	0	353
LZ	42	31	0	29	9	0	24	10	0	0	0	0	73	38	34	0	53	52	40	0	145
<b>KFZ</b>	<b>3644</b>	<b>1956</b>	<b>0</b>	<b>3424</b>	<b>736</b>	<b>0</b>	<b>1677</b>	<b>799</b>	<b>0</b>	<b>0</b>	<b>0</b>	<b>0</b>	<b>5600</b>	<b>4160</b>	<b>2476</b>	<b>0</b>	<b>5101</b>	<b>4443</b>	<b>2692</b>	<b>0</b>	<b>12236</b>
SV	132	103	0	141	50	0	91	26	0	0	0	0	235	191	117	0	232	158	153	0	543
PV	3314	1759	0	3116	658	0	1505	731	0	0	0	0	5073	3774	2236	0	4621	4045	2417	0	11083
GV	330	197	0	308	78	0	172	68	0	0	0	0	527	386	240	0	480	398	275	0	1153
<b>FZ-ART</b>	<b>1-2</b>	<b>1-3</b>	<b>1-4</b>	<b>2-1</b>	<b>2-3</b>	<b>2-4</b>	<b>3-1</b>	<b>3-2</b>	<b>3-4</b>	<b>4-1</b>	<b>4-2</b>	<b>4-3</b>	<b>Zu. 1</b>	<b>Zu. 2</b>	<b>Zu. 3</b>	<b>Zu. 4</b>	<b>Ab. 1</b>	<b>Ab. 2</b>	<b>Ab. 3</b>	<b>Ab. 4</b>	<b>K-Sum</b>

**Summe Zählintervall 06:00 Uhr - 10:00 Uhr**

FZ-ART	1-2	1-3	1-4	2-1	2-3	2-4	3-1	3-2	3-4	4-1	4-2	4-3	Zu. 1	Zu. 2	Zu. 3	Zu. 4	Ab. 1	Ab. 2	Ab. 3	Ab. 4	K-Sum
RAD	8	21	0	5	0	0	3	18	0	0	0	0	29	5	21	0	8	26	21	0	55
KRAD	74	20	0	16	0	0	11	14	0	0	0	0	94	16	25	0	27	88	20	0	135
PKW	2043	877	0	647	103	0	516	520	0	0	0	0	2920	750	1036	0	1163	2563	980	0	4706
BUS	8	8	0	6	1	0	3	2	0	0	0	0	16	7	5	0	9	10	9	0	28
LFW	150	54	0	68	12	0	31	27	0	0	0	0	204	80	58	0	99	177	66	0	342
LKW	51	36	0	59	21	0	41	10	0	0	0	0	87	80	51	0	100	61	57	0	218
LZ	21	22	0	16	5	0	13	4	0	0	0	0	43	21	17	0	29	25	27	0	81
<b>KFZ</b>	<b>2347</b>	<b>1017</b>	<b>0</b>	<b>812</b>	<b>142</b>	<b>0</b>	<b>615</b>	<b>577</b>	<b>0</b>	<b>0</b>	<b>0</b>	<b>0</b>	<b>3364</b>	<b>954</b>	<b>1192</b>	<b>0</b>	<b>1427</b>	<b>2924</b>	<b>1159</b>	<b>0</b>	<b>5510</b>
SV	80	66	0	81	27	0	57	16	0	0	0	0	146	108	73	0	138	96	93	0	327
PV	2125	905	0	669	104	0	530	536	0	0	0	0	3030	773	1066	0	1199	2661	1009	0	4869
GV	222	112	0	143	38	0	85	41	0	0	0	0	334	181	126	0	228	263	150	0	641
<b>FZ-ART</b>	<b>1-2</b>	<b>1-3</b>	<b>1-4</b>	<b>2-1</b>	<b>2-3</b>	<b>2-4</b>	<b>3-1</b>	<b>3-2</b>	<b>3-4</b>	<b>4-1</b>	<b>4-2</b>	<b>4-3</b>	<b>Zu. 1</b>	<b>Zu. 2</b>	<b>Zu. 3</b>	<b>Zu. 4</b>	<b>Ab. 1</b>	<b>Ab. 2</b>	<b>Ab. 3</b>	<b>Ab. 4</b>	<b>K-Sum</b>

**Summe Zählintervall 15:00 Uhr - 19:00 Uhr**

FZ-ART	1-2	1-3	1-4	2-1	2-3	2-4	3-1	3-2	3-4	4-1	4-2	4-3	Zu. 1	Zu. 2	Zu. 3	Zu. 4	Ab. 1	Ab. 2	Ab. 3	Ab. 4	K-Sum
RAD	18	4	0	26	7	0	17	7	0	0	0	0	22	33	24	0	43	25	11	0	79
KRAD	41	51	0	110	34	0	39	8	0	0	0	0	92	144	47	0	149	49	85	0	283
PKW	1141	803	0	2335	518	0	931	186	0	0	0	0	1944	2853	1117	0	3266	1327	1321	0	5914
BUS	7	0	0	2	2	0	5	1	0	0	0	0	7	4	6	0	7	8	2	0	17
LFW	63	48	0	107	19	0	58	18	0	0	0	0	111	126	76	0	165	81	67	0	313
LKW	24	28	0	45	17	0	18	3	0	0	0	0	52	62	21	0	63	27	45	0	135
LZ	21	9	0	13	4	0	11	6	0	0	0	0	30	17	17	0	24	27	13	0	64
<b>KFZ</b>	<b>1297</b>	<b>939</b>	<b>0</b>	<b>2612</b>	<b>594</b>	<b>0</b>	<b>1062</b>	<b>222</b>	<b>0</b>	<b>0</b>	<b>0</b>	<b>0</b>	<b>2236</b>	<b>3206</b>	<b>1284</b>	<b>0</b>	<b>3674</b>	<b>1519</b>	<b>1533</b>	<b>0</b>	<b>6726</b>
SV	52	37	0	60	23	0	34	10	0	0	0	0	89	83	44	0	94	62	60	0	216
PV	1189	854	0	2447	554	0	975	195	0	0	0	0	2043	3001	1170	0	3422	1384	1408	0	6214
GV	108	85	0	165	40	0	87	27	0	0	0	0	193	205	114	0	252	135	125	0	512
<b>FZ-ART</b>	<b>1-2</b>	<b>1-3</b>	<b>1-4</b>	<b>2-1</b>	<b>2-3</b>	<b>2-4</b>	<b>3-1</b>	<b>3-2</b>	<b>3-4</b>	<b>4-1</b>	<b>4-2</b>	<b>4-3</b>	<b>Zu. 1</b>	<b>Zu. 2</b>	<b>Zu. 3</b>	<b>Zu. 4</b>	<b>Ab. 1</b>	<b>Ab. 2</b>	<b>Ab. 3</b>	<b>Ab. 4</b>	<b>K-Sum</b>

**spezifische Spitzenstunde morgens 07:15 Uhr - 08:15 Uhr**

FZ-ART	1-2	1-3	1-4	2-1	2-3	2-4	3-1	3-2	3-4	4-1	4-2	4-3	Zu. 1	Zu. 2	Zu. 3	Zu. 4	Ab. 1	Ab. 2	Ab. 3	Ab. 4	K-Sum
RAD	6	14	0	0	0	0	0	9	0	0	0	0	20	0	9	0	0	15	14	0	29
KRAD	30	7	0	5	0	0	3	4	0	0	0	0	37	5	7	0	8	34	7	0	49
PKW	705	309	0	166	23	0	188	189	0	0	0	0	1014	189	377	0	354	894	332	0	1580
BUS	4	3	0	2	0	0	3	1	0	0	0	0	7	2	4	0	5	5	3	0	13
LFW	49	14	0	17	0	0	10	8	0	0	0	0	63	17	18	0	27	57	14	0	98
LKW	6	6	0	10	8	0	11	0	0	0	0	0	12	18	11	0	21	6	14	0	41
LZ	3	5	0	3	0	0	2	0	0	0	0	0	8	3	2	0	5	3	5	0	13
<b>KFZ</b>	<b>797</b>	<b>344</b>	<b>0</b>	<b>203</b>	<b>31</b>	<b>0</b>	<b>217</b>	<b>202</b>	<b>0</b>	<b>0</b>	<b>0</b>	<b>0</b>	<b>1141</b>	<b>234</b>	<b>419</b>	<b>0</b>	<b>420</b>	<b>999</b>	<b>375</b>	<b>0</b>	<b>1794</b>
SV	13	14	0	15	8	0	16	1	0	0	0	0	27	23	17	0	31	14	22	0	67
PV	739	319	0	173	23	0	194	194	0	0	0	0	1058	196	388	0	367	933	342	0	1642
GV	58	25	0	30	8	0	23	8	0	0	0	0	83	38	31	0	53	66	33	0	152
<b>FZ-ART</b>	<b>1-2</b>	<b>1-3</b>	<b>1-4</b>	<b>2-1</b>	<b>2-3</b>	<b>2-4</b>	<b>3-1</b>	<b>3-2</b>	<b>3-4</b>	<b>4-1</b>	<b>4-2</b>	<b>4-3</b>	<b>Zu. 1</b>	<b>Zu. 2</b>	<b>Zu. 3</b>	<b>Zu. 4</b>	<b>Ab. 1</b>	<b>Ab. 2</b>	<b>Ab. 3</b>	<b>Ab. 4</b>	<b>K-Sum</b>

**spezifische Spitzenstunde abends 16:45 Uhr - 17:45 Uhr**

FZ-ART	1-2	1-3	1-4	2-1	2-3	2-4	3-1	3-2	3-4	4-1	4-2	4-3	Zu. 1	Zu. 2	Zu. 3	Zu. 4	Ab. 1	Ab. 2	Ab. 3	Ab. 4	K-Sum
RAD	6	0	0	7	1	0	5	0	0	0	0	0	6	8	5	0	12	6	1	0	19
KRAD	10	12	0	24	12	0	12	2	0	0	0	0	22	36	14	0	36	12	24	0	72
PKW	279	211	0	666	164	0	276	49	0	0	0	0	490	830	325	0	942	328	375	0	1645
BUS	2	0	0	0	1	0	0	0	0	0	0	0	2	1	0	0	0	2	1	0	3
LFW	17	14	0	33	7	0	19	6	0	0	0	0	31	40	25	0	52	23	21	0	96



# Stadt Dachau

Zählstelle: K28 ST2339 / Alte Römerstraße

Zusammenfassung Stundengruppen

Zähltag: Do., 26.04.2007

Zu-/Ablauf 1: ST2339 (von/nach Freising)

Zu-/Ablauf 2: Alte Römerstr.

Zu-/Ablauf 3: St2339 (von/nach Etzenhausen)

Spezifische Spitzenstunde morgens  
07:15 Uhr - 08:15 Uhr in KFZ

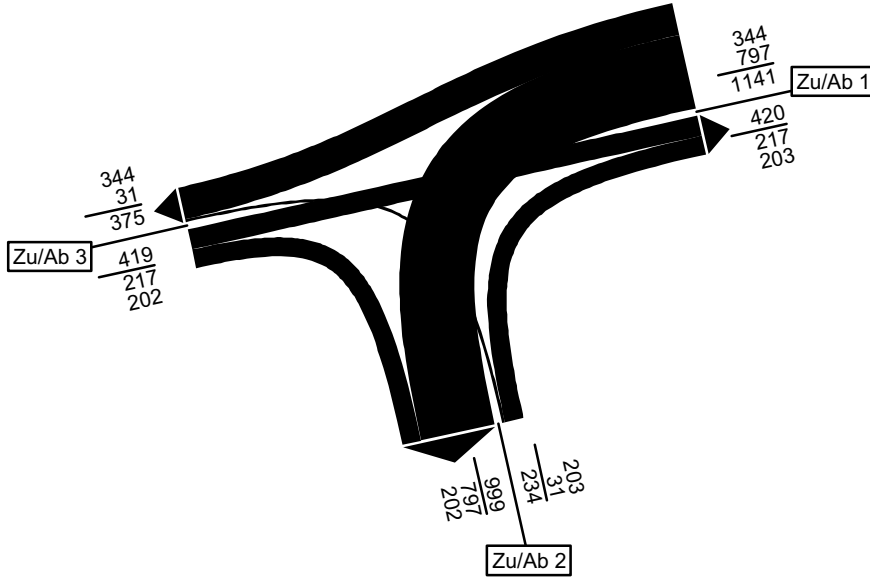

Spezifische Spitzenstunde abends  
16:45 Uhr - 17:45 Uhr in KFZ

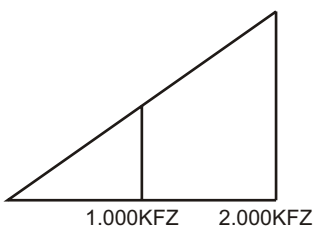
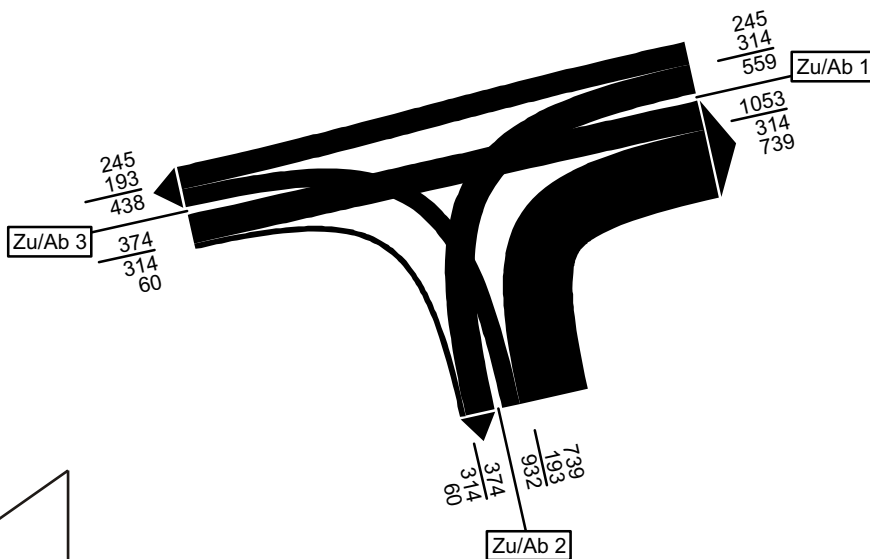

# Stadt Dachau

Zählstelle: K29 Augustenfelder Straße / Obere Moosswaigestraße

Zu-/Ablauf 1: Obere Mooswaigestr.

Zu-/Ablauf 2: Augustenfelder Str. (von/nach Stadtauswärts)

Zu-/Ablauf 3: Augustenfelder Str. (von/nach Stadteinwärts)

Zusammenfassung Stundengruppen

Zähltag: Do., 26.04.2007

Zählzeit: 06:00 Uhr - 10:00 Uhr und 15:00 Uhr - 19:00 Uhr

## Summe Zählzeit (06:00 Uhr - 10:00 Uhr und 15:00 Uhr - 19:00 Uhr)

FZ-ART	1-2	1-3	1-4	2-1	2-3	2-4	3-1	3-2	3-4	4-1	4-2	4-3	Zu. 1	Zu. 2	Zu. 3	Zu. 4	Ab. 1	Ab. 2	Ab. 3	Ab. 4	K-Sum
RAD	193	54	0	353	113	0	48	133	0	0	0	0	247	466	181	0	401	326	167	0	894
KRAD	6	13	0	22	15	0	17	9	0	0	0	0	19	37	26	0	39	15	28	0	82
PKW	262	284	0	297	215	0	257	244	0	0	0	0	546	512	501	0	554	506	499	0	1559
BUS	0	0	0	0	0	0	0	0	0	0	0	0	0	0	0	0	0	0	0	0	0
LFW	9	2	0	7	8	0	7	13	0	0	0	0	11	15	20	0	14	22	10	0	46
LKW	5	1	0	0	0	0	2	1	0	0	0	0	6	0	3	0	2	6	1	0	9
LZ	2	0	0	3	0	0	0	0	0	0	0	0	2	3	0	0	3	2	0	0	5
<b>KFZ</b>	<b>284</b>	<b>300</b>	<b>0</b>	<b>329</b>	<b>238</b>	<b>0</b>	<b>283</b>	<b>267</b>	<b>0</b>	<b>0</b>	<b>0</b>	<b>0</b>	<b>584</b>	<b>567</b>	<b>550</b>	<b>0</b>	<b>612</b>	<b>551</b>	<b>538</b>	<b>0</b>	<b>1701</b>
SV	7	1	0	3	0	0	2	1	0	0	0	0	8	3	3	0	5	8	1	0	14
PV	268	297	0	319	230	0	274	253	0	0	0	0	565	549	527	0	593	521	527	0	1641
GV	16	3	0	10	8	0	9	14	0	0	0	0	19	18	23	0	19	30	11	0	60
<b>FZ-ART</b>	<b>1-2</b>	<b>1-3</b>	<b>1-4</b>	<b>2-1</b>	<b>2-3</b>	<b>2-4</b>	<b>3-1</b>	<b>3-2</b>	<b>3-4</b>	<b>4-1</b>	<b>4-2</b>	<b>4-3</b>	<b>Zu. 1</b>	<b>Zu. 2</b>	<b>Zu. 3</b>	<b>Zu. 4</b>	<b>Ab. 1</b>	<b>Ab. 2</b>	<b>Ab. 3</b>	<b>Ab. 4</b>	<b>K-Sum</b>

## Summe Zählintervall 06:00 Uhr - 10:00 Uhr

FZ-ART	1-2	1-3	1-4	2-1	2-3	2-4	3-1	3-2	3-4	4-1	4-2	4-3	Zu. 1	Zu. 2	Zu. 3	Zu. 4	Ab. 1	Ab. 2	Ab. 3	Ab. 4	K-Sum
RAD	40	17	0	269	43	0	16	27	0	0	0	0	57	312	43	0	285	67	60	0	412
KRAD	2	3	0	16	1	0	4	6	0	0	0	0	5	17	10	0	20	8	4	0	32
PKW	110	59	0	158	84	0	180	84	0	0	0	0	169	242	264	0	338	194	143	0	675
BUS	0	0	0	0	0	0	0	0	0	0	0	0	0	0	0	0	0	0	0	0	0
LFW	7	1	0	1	5	0	2	10	0	0	0	0	8	6	12	0	3	17	6	0	26
LKW	5	0	0	0	0	0	0	1	0	0	0	0	5	0	1	0	0	6	0	0	6
LZ	1	0	0	1	0	0	0	0	0	0	0	0	1	1	0	0	1	1	0	0	2
<b>KFZ</b>	<b>125</b>	<b>63</b>	<b>0</b>	<b>176</b>	<b>90</b>	<b>0</b>	<b>186</b>	<b>101</b>	<b>0</b>	<b>0</b>	<b>0</b>	<b>0</b>	<b>188</b>	<b>266</b>	<b>287</b>	<b>0</b>	<b>362</b>	<b>226</b>	<b>153</b>	<b>0</b>	<b>741</b>
SV	6	0	0	1	0	0	0	1	0	0	0	0	6	1	1	0	1	7	0	0	8
PV	112	62	0	174	85	0	184	90	0	0	0	0	174	259	274	0	358	202	147	0	707
GV	13	1	0	2	5	0	2	11	0	0	0	0	14	7	13	0	4	24	6	0	34
<b>FZ-ART</b>	<b>1-2</b>	<b>1-3</b>	<b>1-4</b>	<b>2-1</b>	<b>2-3</b>	<b>2-4</b>	<b>3-1</b>	<b>3-2</b>	<b>3-4</b>	<b>4-1</b>	<b>4-2</b>	<b>4-3</b>	<b>Zu. 1</b>	<b>Zu. 2</b>	<b>Zu. 3</b>	<b>Zu. 4</b>	<b>Ab. 1</b>	<b>Ab. 2</b>	<b>Ab. 3</b>	<b>Ab. 4</b>	<b>K-Sum</b>

## Summe Zählintervall 15:00 Uhr - 19:00 Uhr

FZ-ART	1-2	1-3	1-4	2-1	2-3	2-4	3-1	3-2	3-4	4-1	4-2	4-3	Zu. 1	Zu. 2	Zu. 3	Zu. 4	Ab. 1	Ab. 2	Ab. 3	Ab. 4	K-Sum
RAD	153	37	0	84	70	0	32	106	0	0	0	0	190	154	138	0	116	259	107	0	482
KRAD	4	10	0	6	14	0	13	3	0	0	0	0	14	20	16	0	19	7	24	0	50
PKW	152	225	0	139	131	0	77	160	0	0	0	0	377	270	237	0	216	312	356	0	884
BUS	0	0	0	0	0	0	0	0	0	0	0	0	0	0	0	0	0	0	0	0	0
LFW	2	1	0	6	3	0	5	3	0	0	0	0	3	9	8	0	11	5	4	0	20
LKW	0	1	0	0	0	0	2	0	0	0	0	0	1	0	2	0	2	0	1	0	3
LZ	1	0	0	2	0	0	0	0	0	0	0	0	1	2	0	0	2	1	0	0	3
<b>KFZ</b>	<b>159</b>	<b>237</b>	<b>0</b>	<b>153</b>	<b>148</b>	<b>0</b>	<b>97</b>	<b>166</b>	<b>0</b>	<b>0</b>	<b>0</b>	<b>0</b>	<b>396</b>	<b>301</b>	<b>263</b>	<b>0</b>	<b>250</b>	<b>325</b>	<b>385</b>	<b>0</b>	<b>960</b>
SV	1	1	0	2	0	0	2	0	0	0	0	0	2	2	2	0	1	2	1	0	6
PV	156	235	0	145	145	0	90	163	0	0	0	0	391	290	253	0	235	319	380	0	934
GV	3	2	0	8	3	0	7	3	0	0	0	0	5	11	10	0	15	6	5	0	26
<b>FZ-ART</b>	<b>1-2</b>	<b>1-3</b>	<b>1-4</b>	<b>2-1</b>	<b>2-3</b>	<b>2-4</b>	<b>3-1</b>	<b>3-2</b>	<b>3-4</b>	<b>4-1</b>	<b>4-2</b>	<b>4-3</b>	<b>Zu. 1</b>	<b>Zu. 2</b>	<b>Zu. 3</b>	<b>Zu. 4</b>	<b>Ab. 1</b>	<b>Ab. 2</b>	<b>Ab. 3</b>	<b>Ab. 4</b>	<b>K-Sum</b>

## spezifische Spitzenstunde morgens 07:30 Uhr - 08:30 Uhr

FZ-ART	1-2	1-3	1-4	2-1	2-3	2-4	3-1	3-2	3-4	4-1	4-2	4-3	Zu. 1	Zu. 2	Zu. 3	Zu. 4	Ab. 1	Ab. 2	Ab. 3	Ab. 4	K-Sum
RAD	12	4	0	166	22	0	7	13	0	0	0	0	16	188	20	0	173	25	26	0	224
KRAD	0	2	0	13	1	0	2	4	0	0	0	0	2	14	6	0	15	4	3	0	22
PKW	47	24	0	59	36	0	69	19	0	0	0	0	71	95	88	0	128	66	60	0	254
BUS	0	0	0	0	0	0	0	0	0	0	0	0	0	0	0	0	0	0	0	0	0
LFW	2	1	0	1	1	0	0	3	0	0	0	0	3	2	3	0	1	5	2	0	8
LKW	2	0	0	0	0	0	0	0	0	0	0	0	2	0	0	0	0	2	0	0	2
LZ	0	0	0	1	0	0	0	0	0	0	0	0	0	1	0	0	1	0	0	0	1
<b>KFZ</b>	<b>51</b>	<b>27</b>	<b>0</b>	<b>74</b>	<b>38</b>	<b>0</b>	<b>71</b>	<b>26</b>	<b>0</b>	<b>0</b>	<b>0</b>	<b>0</b>	<b>78</b>	<b>112</b>	<b>97</b>	<b>0</b>	<b>145</b>	<b>77</b>	<b>65</b>	<b>0</b>	<b>287</b>
SV	2	0	0	1	0	0	0	0	0	0	0	0	2	1	0	0	1	2	0	0	3
PV	47	26	0	72	37	0	71	23	0	0	0	0	73	109	94	0	143	70	63	0	276
GV	4	1	0	2	1	0	0	3	0	0	0	0	5	3	3	0	2	7	2	0	11
<b>FZ-ART</b>	<b>1-2</b>	<b>1-3</b>	<b>1-4</b>	<b>2-1</b>	<b>2-3</b>	<b>2-4</b>	<b>3-1</b>	<b>3-2</b>	<b>3-4</b>	<b>4-1</b>	<b>4-2</b>	<b>4-3</b>	<b>Zu. 1</b>	<b>Zu. 2</b>	<b>Zu. 3</b>	<b>Zu. 4</b>	<b>Ab. 1</b>	<b>Ab. 2</b>	<b>Ab. 3</b>	<b>Ab. 4</b>	<b>K-Sum</b>

## spezifische Spitzenstunde abends 17:15 Uhr - 18:15 Uhr

FZ-ART	1-2	1-3	1-4	2-1	2-3	2-4	3-1	3-2	3-4	4-1	4-2	4-3	Zu. 1	Zu. 2	Zu. 3	Zu. 4	Ab. 1	Ab. 2	Ab. 3	Ab. 4	K-Sum
RAD	36	5	0	19	16	0	10	33	0	0	0	0	41	35	43	0	29	69	21	0	119
KRAD	1	2	0	1	2	0	3	1	0	0	0	0	3	3	4	0	4	2	4	0	10
PKW	48	83	0	49	45	0	18	58	0	0	0	0	131	94	76	0	67	106	128	0	301
BUS	0	0	0	0	0	0	0	0	0	0	0	0	0	0	0	0	0	0	0	0	0
LFW	1	1	0	1	2	0	2	2	0	0	0	0	2	3	4	0	3	3	3	0	9
LKW	0	0	0	0	0	0	0	0	0	0	0	0	0	0	0	0	0	0	0	0	0
LZ	0	0	0	1	0	0	0	0	0	0	0	0	0	1	0	0	1	0	0	0	1
<b>KFZ</b>	<b>50</b>	<b>86</b>	<b>0</b>	<b>52</b>	<b>49</b>	<b>0</b>	<b>23</b> </														

# Stadt Dachau

Zählstelle: K29 Augustenfelder Straße / Obere Moosswaigestraße

Zusammenfassung Stundengruppen

Zähltag: Do., 26.04.2007

Zu-/Ablauf 1: Obere Mooswaigestr.

Zu-/Ablauf 2: Augustenfelder Str. (von/nach Stadtauswärts)

Zu-/Ablauf 3: Augustenfelder Str. (von/nach Stadteinwärts)

Spezifische Spitzenstunde morgens  
07:30 Uhr - 08:30 Uhr in KFZ

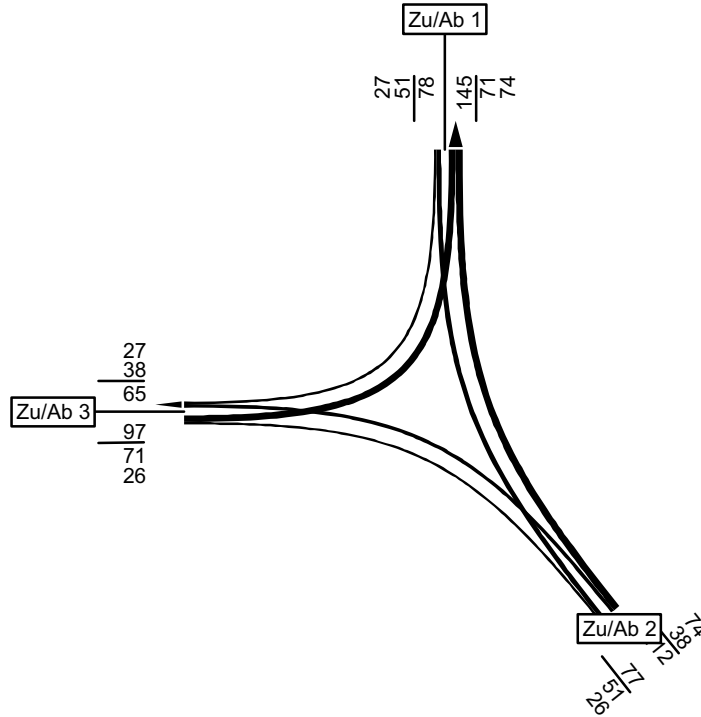

Spezifische Spitzenstunde abends  
17:15 Uhr - 18:15 Uhr in KFZ

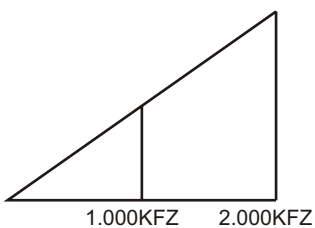
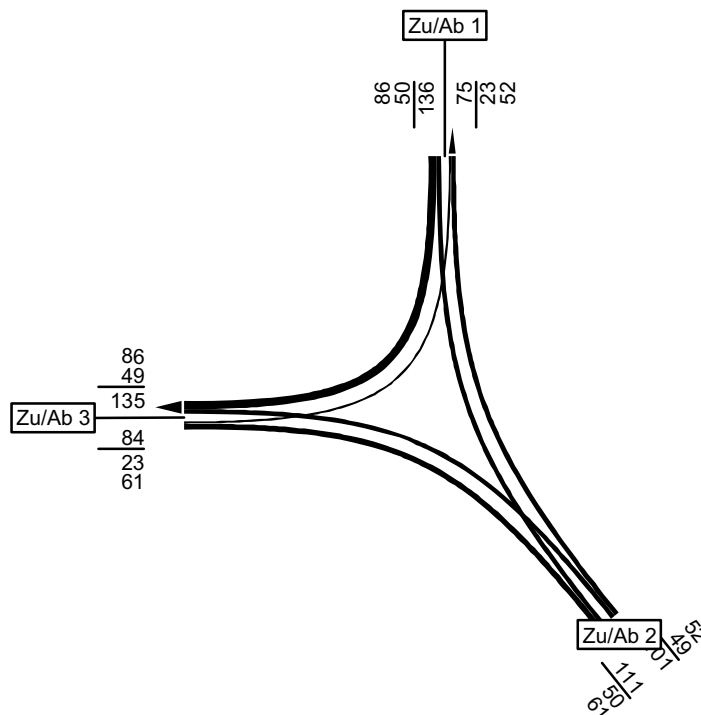



# Stadt Dachau

Zählstelle: K30 Sudetenlandstraße / Theodor-Heuss-Straße

Zusammenfassung Stundengruppen

Zähltag: Do., 26.04.2007

Zu-/Ablauf 1: Sudetenlandstr. (von/nach Stadtauswärts)

Zu-/Ablauf 2: Theodor-Heuss-Str.

Zu-/Ablauf 3: Sudetenlandstr. (von/nach Stadteinwärts)

Zu-/Ablauf 4: J.-F.-Kennedy-Platz

Spezifische Spitzenstunde morgens  
07:45 Uhr - 08:45 Uhr in KFZ

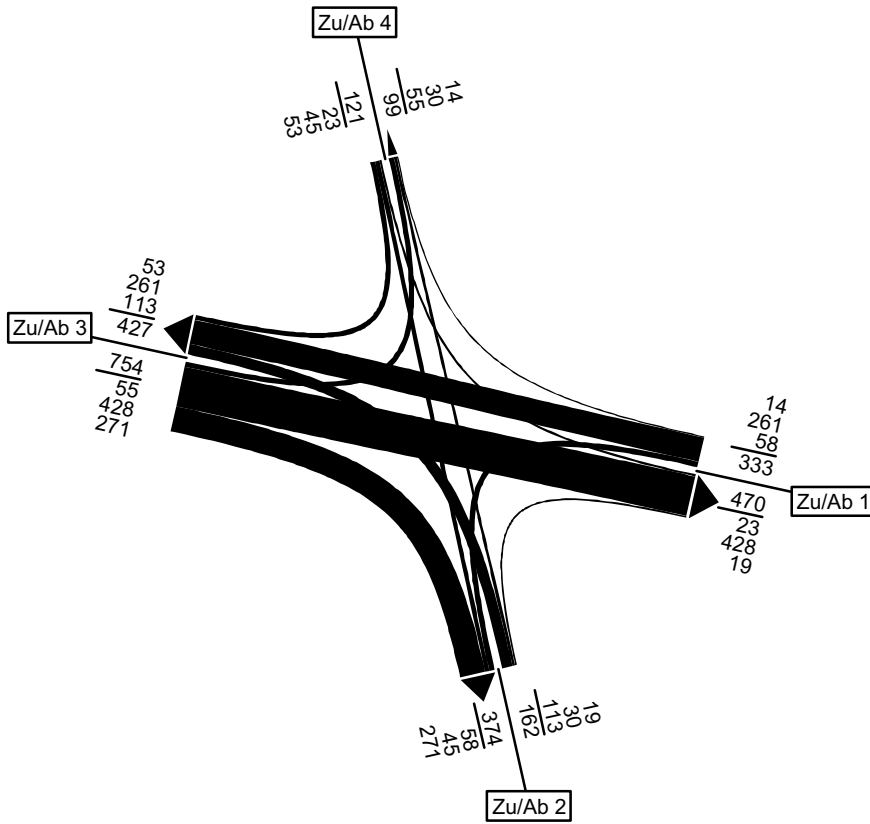

Spezifische Spitzenstunde abends  
16:15 Uhr - 17:15 Uhr in KFZ

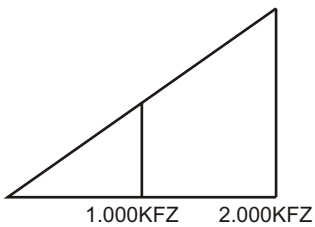
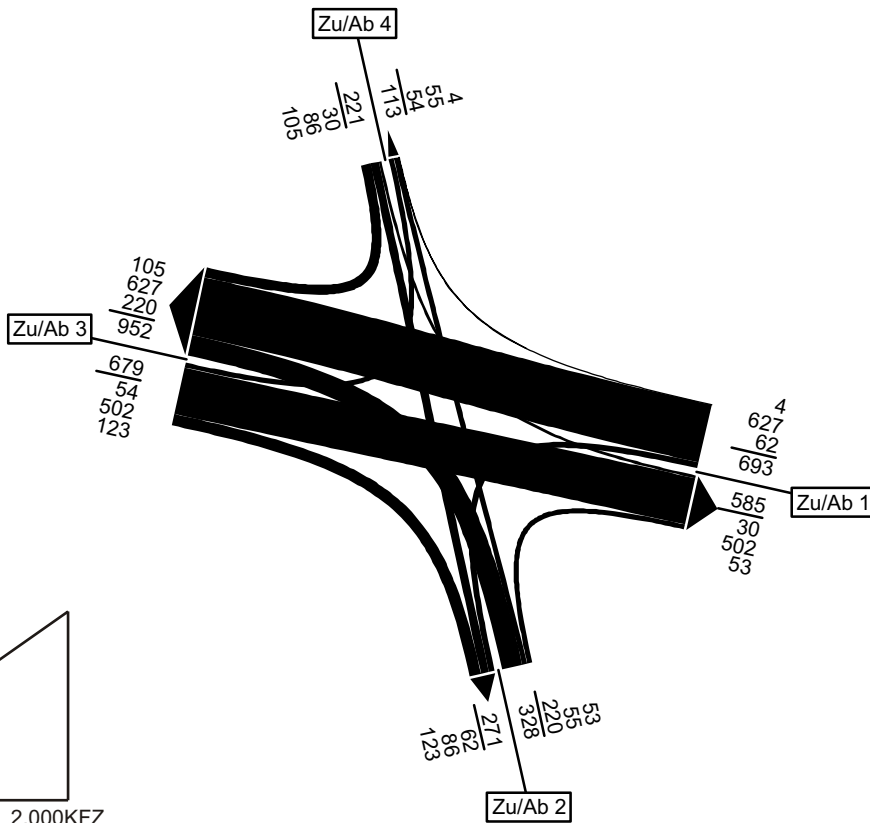



# Stadt Dachau

Zählstelle: K31 Theodor-Heuss-Straße / Wallbergstraße

Zusammenfassung Stundengruppen

Zähltag: Do., 26.04.2007

Zu-/Ablauf 1: Theodor-Heuss-Str. (von/nach Stadteinwärts)

Zu-/Ablauf 2: Theodor-Heuss-Str. (von/nach Stadtauswärts)

Zu-/Ablauf 3: Wallbergstr.

Spezifische Spitzenstunde morgens  
07:15 Uhr - 08:15 Uhr in KFZ

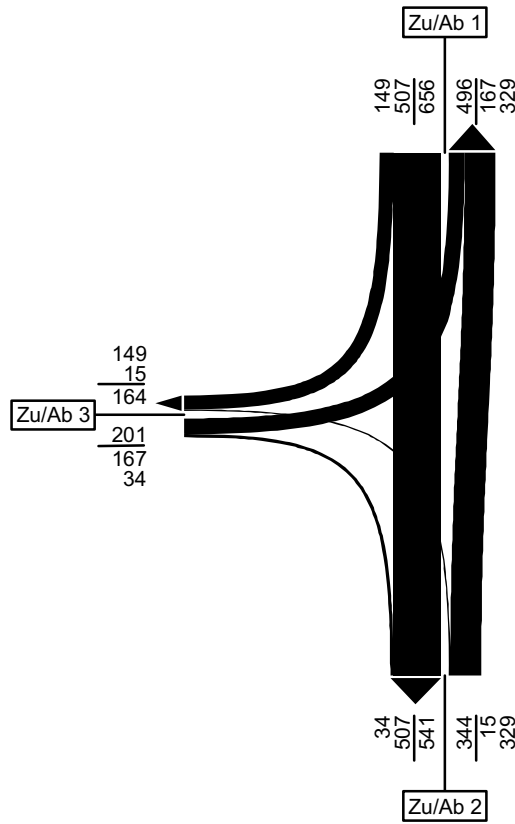

Spezifische Spitzenstunde abends  
16:30 Uhr - 17:30 Uhr in KFZ

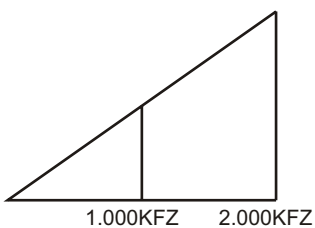
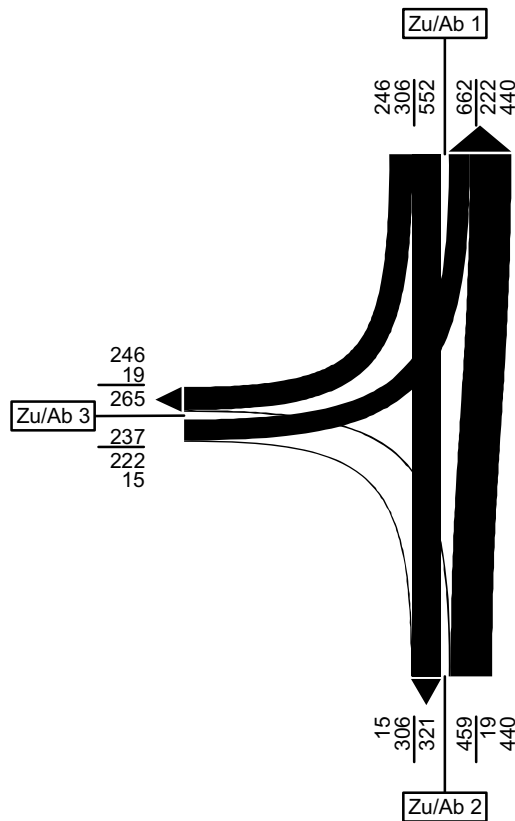







**Stadt Dachau**

Zählstelle: K33 Münchener Straße / Wallbergstraße

Zu-/Ablauf 1: Wallbergstr.  
 Zu-/Ablauf 2: Münchener Str. (von/nach Stadttauswärts)  
 Zu-/Ablauf 3: Wettersteinring  
 Zu-/Ablauf 4: Münchener Str. (von/nach Stadteinwärts)

Zusammenfassung Stundengruppen

Zähltag: Do., 26.04.2007  
 Zählzeit: 06:00 Uhr - 10:00 Uhr und 15:00 Uhr - 19:00 Uhr

**Summe Zählzeit (06:00 Uhr - 10:00 Uhr und 15:00 Uhr - 19:00 Uhr)**

FZ-ART	1-2	1-3	1-4	2-1	2-3	2-4	3-1	3-2	3-4	4-1	4-2	4-3	Zu. 1	Zu. 2	Zu. 3	Zu. 4	Ab. 1	Ab. 2	Ab. 3	Ab. 4	K-Sum
RAD	0	217	37	0	1	390	62	3	2	0	37	26	254	391	67	63	62	40	244	429	775
KRAD	3	11	42	4	2	138	8	2	12	30	72	7	56	144	22	109	42	77	20	192	331
PKW	197	293	947	208	384	4962	236	285	514	972	5325	477	1437	5554	1035	6774	1416	5807	1154	6423	14800
BUS	0	1	17	0	0	16	0	5	0	12	19	1	18	16	5	32	12	24	2	33	71
LFW	19	1	33	16	3	147	10	16	10	45	358	6	53	166	36	409	71	393	10	190	664
LKW	3	0	24	5	4	82	6	6	6	29	109	6	27	91	18	144	40	118	10	112	280
LZ	0	1	2	2	3	30	1	2	0	0	12	0	3	35	3	12	3	14	4	32	53
<b>KFZ</b>	<b>222</b>	<b>307</b>	<b>1065</b>	<b>235</b>	<b>396</b>	<b>5375</b>	<b>261</b>	<b>316</b>	<b>542</b>	<b>1088</b>	<b>5895</b>	<b>497</b>	<b>1594</b>	<b>6006</b>	<b>1119</b>	<b>7480</b>	<b>1584</b>	<b>6433</b>	<b>1200</b>	<b>6982</b>	<b>16199</b>
SV	3	2	43	7	7	128	7	13	6	41	140	7	48	142	26	188	55	156	16	177	404
PV	200	305	1006	212	386	5116	244	292	526	1014	5416	485	1511	5714	1062	6915	1470	5908	1176	6648	15202
GV	22	2	59	23	10	259	17	24	16	74	479	12	83	292	57	565	114	525	24	334	997
<b>FZ-ART</b>	<b>1-2</b>	<b>1-3</b>	<b>1-4</b>	<b>2-1</b>	<b>2-3</b>	<b>2-4</b>	<b>3-1</b>	<b>3-2</b>	<b>3-4</b>	<b>4-1</b>	<b>4-2</b>	<b>4-3</b>	<b>Zu. 1</b>	<b>Zu. 2</b>	<b>Zu. 3</b>	<b>Zu. 4</b>	<b>Ab. 1</b>	<b>Ab. 2</b>	<b>Ab. 3</b>	<b>Ab. 4</b>	<b>K-Sum</b>

**Summe Zählintervall 06:00 Uhr - 10:00 Uhr**

FZ-ART	1-2	1-3	1-4	2-1	2-3	2-4	3-1	3-2	3-4	4-1	4-2	4-3	Zu. 1	Zu. 2	Zu. 3	Zu. 4	Ab. 1	Ab. 2	Ab. 3	Ab. 4	K-Sum
RAD	0	60	9	0	1	172	23	0	1	0	11	4	69	173	24	15	23	11	65	182	281
KRAD	2	4	7	1	1	13	4	2	3	11	45	0	13	15	9	56	16	49	5	23	93
PKW	123	122	335	38	143	1343	87	106	178	383	3375	224	580	1524	371	3982	508	3604	489	1856	6457
BUS	0	0	10	0	0	10	0	5	0	6	13	1	10	10	5	20	6	18	1	20	45
LFW	13	1	15	4	2	65	9	12	3	26	229	3	29	71	24	256	39	254	6	83	382
LKW	2	0	17	1	1	49	3	2	4	16	75	3	19	51	9	94	20	79	4	70	173
LZ	0	1	1	1	1	14	1	0	0	0	5	0	2	16	1	5	2	5	2	15	24
<b>KFZ</b>	<b>140</b>	<b>128</b>	<b>385</b>	<b>45</b>	<b>148</b>	<b>1494</b>	<b>104</b>	<b>127</b>	<b>188</b>	<b>442</b>	<b>3742</b>	<b>231</b>	<b>653</b>	<b>1687</b>	<b>419</b>	<b>4415</b>	<b>591</b>	<b>4009</b>	<b>507</b>	<b>2067</b>	<b>7174</b>
SV	2	1	28	2	2	73	4	7	4	22	93	4	31	77	15	119	28	102	7	105	242
PV	125	126	352	39	144	1366	91	113	181	400	3433	225	603	1549	385	4058	530	3671	495	1899	6595
GV	15	2	33	6	4	128	13	14	7	42	309	6	50	138	34	357	61	338	12	168	579
<b>FZ-ART</b>	<b>1-2</b>	<b>1-3</b>	<b>1-4</b>	<b>2-1</b>	<b>2-3</b>	<b>2-4</b>	<b>3-1</b>	<b>3-2</b>	<b>3-4</b>	<b>4-1</b>	<b>4-2</b>	<b>4-3</b>	<b>Zu. 1</b>	<b>Zu. 2</b>	<b>Zu. 3</b>	<b>Zu. 4</b>	<b>Ab. 1</b>	<b>Ab. 2</b>	<b>Ab. 3</b>	<b>Ab. 4</b>	<b>K-Sum</b>

**Summe Zählintervall 15:00 Uhr - 19:00 Uhr**

FZ-ART	1-2	1-3	1-4	2-1	2-3	2-4	3-1	3-2	3-4	4-1	4-2	4-3	Zu. 1	Zu. 2	Zu. 3	Zu. 4	Ab. 1	Ab. 2	Ab. 3	Ab. 4	K-Sum
RAD	0	157	28	0	0	218	39	3	1	0	26	22	185	218	43	48	39	29	179	247	494
KRAD	1	7	35	3	1	125	4	0	9	19	27	7	43	129	13	53	26	28	15	169	238
PKW	74	171	612	170	241	3619	149	179	336	589	1950	253	857	4030	664	2792	908	2203	665	4567	8343
BUS	0	1	7	0	0	6	0	0	0	6	6	0	8	6	0	12	6	6	1	13	26
LFW	6	0	18	12	1	82	1	4	7	19	129	3	24	95	12	151	32	139	4	107	282
LKW	1	0	7	4	3	33	3	4	2	13	34	3	8	40	9	50	20	39	6	42	107
LZ	0	0	1	1	2	16	0	2	0	0	7	0	1	19	2	7	1	9	2	17	29
<b>KFZ</b>	<b>82</b>	<b>179</b>	<b>680</b>	<b>190</b>	<b>248</b>	<b>3881</b>	<b>157</b>	<b>189</b>	<b>354</b>	<b>646</b>	<b>2153</b>	<b>266</b>	<b>941</b>	<b>4319</b>	<b>700</b>	<b>3065</b>	<b>993</b>	<b>2424</b>	<b>693</b>	<b>4915</b>	<b>9025</b>
SV	1	1	15	5	5	55	3	6	2	19	47	3	17	65	11	69	27	54	9	72	162
PV	75	179	654	173	242	3750	153	179	345	614	1983	260	908	4165	677	2857	940	2237	681	4749	8607
GV	7	0	26	17	6	131	4	10	9	32	170	6	33	154	23	208	53	187	12	166	418
<b>FZ-ART</b>	<b>1-2</b>	<b>1-3</b>	<b>1-4</b>	<b>2-1</b>	<b>2-3</b>	<b>2-4</b>	<b>3-1</b>	<b>3-2</b>	<b>3-4</b>	<b>4-1</b>	<b>4-2</b>	<b>4-3</b>	<b>Zu. 1</b>	<b>Zu. 2</b>	<b>Zu. 3</b>	<b>Zu. 4</b>	<b>Ab. 1</b>	<b>Ab. 2</b>	<b>Ab. 3</b>	<b>Ab. 4</b>	<b>K-Sum</b>

**spezifische Spitzenstunde morgens 07:45 Uhr - 08:45 Uhr**

FZ-ART	1-2	1-3	1-4	2-1	2-3	2-4	3-1	3-2	3-4	4-1	4-2	4-3	Zu. 1	Zu. 2	Zu. 3	Zu. 4	Ab. 1	Ab. 2	Ab. 3	Ab. 4	K-Sum
RAD	0	29	5	0	1	46	10	0	0	0	6	1	34	47	10	7	10	6	31	51	98
KRAD	1	0	2	0	0	2	1	0	1	5	4	0	3	2	2	9	6	5	0	5	16
PKW	26	53	126	13	66	424	24	42	58	126	919	102	205	503	124	1147	163	987	221	608	1979
BUS	0	0	3	0	0	0	0	0	0	1	4	0	3	0	0	5	1	4	0	3	8
LFW	0	0	7	2	1	14	4	0	1	5	54	1	7	17	5	60	11	54	2	22	89
LKW	1	0	4	0	0	12	1	0	0	8	16	0	5	12	1	24	9	17	0	16	42
LZ	0	0	1	0	1	3	0	0	0	0	1	0	1	4	0	1	0	1	1	4	6
<b>KFZ</b>	<b>28</b>	<b>53</b>	<b>143</b>	<b>15</b>	<b>68</b>	<b>455</b>	<b>30</b>	<b>42</b>	<b>60</b>	<b>145</b>	<b>998</b>	<b>103</b>	<b>224</b>	<b>538</b>	<b>132</b>	<b>1246</b>	<b>190</b>	<b>1068</b>	<b>224</b>	<b>658</b>	<b>2140</b>
SV	1	0	8	0	1	15	1	0	0	9	21	0	9	16	1	30	10	22	1	23	56
PV	27	53	131	13	66	426	25	42	59	132	927	102	211	505	126	1161	170	996	221	616	2003
GV	1	0	12	2	2	29	5	0	1	13	71	1	13	33	6	85	20	72	3	42	137
<b>FZ-ART</b>	<b>1-2</b>	<b>1-3</b>	<b>1-4</b>	<b>2-1</b>	<b>2-3</b>	<b>2-4</b>	<b>3-1</b>	<b>3-2</b>	<b>3-4</b>	<b>4-1</b>	<b>4-2</b>	<b>4-3</b>	<b>Zu. 1</b>	<b>Zu. 2</b>	<b>Zu. 3</b>	<b>Zu. 4</b>	<b>Ab. 1</b>	<b>Ab. 2</b>	<b>Ab. 3</b>	<b>Ab. 4</b>	<b>K-Sum</b>

**spezifische Spitzenstunde abends 16:45 Uhr - 17:45 Uhr**

FZ-ART	1-2	1-3	1-4	2-1	2-3	2-4	3-1	3-2	3-4	4-1	4-2	4-3	Zu. 1	Zu. 2	Zu. 3	Zu. 4	Ab. 1	Ab. 2	Ab. 3	Ab. 4	K-Sum
RAD	0	42	13	0	0	44	8	2	1	0	10	5	55	44	11	15	8	12	47	58	125
KRAD	1	2	13	1	0	32	2	0	4	4	9	3	16	33	6	16	7	10	5	49	71
PKW	19	49	187	52	54	979	44	58	103	170	543	69	255	1085	205	782	266	620	172	1269	2327
BUS	0	0	1	0	0	0	0	0	0	2	0	0	1	0	0	2	2	0	0	1	3
LFW	1	0	5	2	0	19	1														

# Stadt Dachau

Zählstelle: K33 Münchener Straße / Wallbergstraße

Zusammenfassung Stundengruppen

Zähltag: Do., 26.04.2007

Zu-/Ablauf 1: Wallbergstr.

Zu-/Ablauf 2: Münchener Str. (von/nach Stadtauswärts)

Zu-/Ablauf 3: Wettersteinring

Zu-/Ablauf 4: Münchener Str. (von/nach Stadteinwärts)

Spezifische Spitzenstunde morgens  
07:45 Uhr - 08:45 Uhr in KFZ

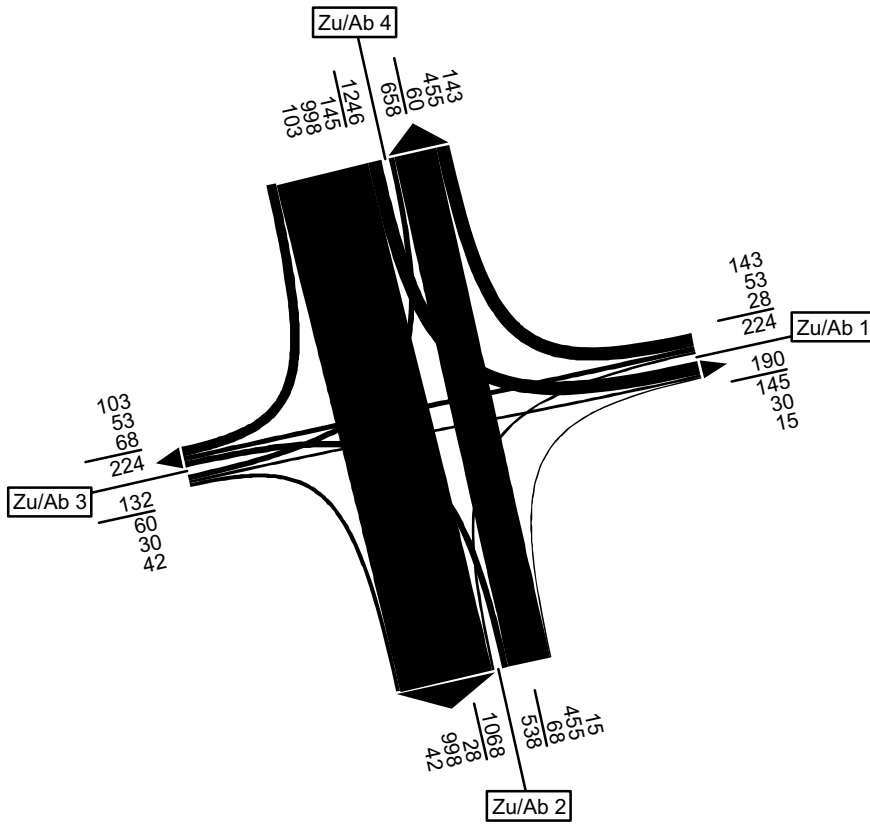

Spezifische Spitzenstunde abends  
16:45 Uhr - 17:45 Uhr in KFZ

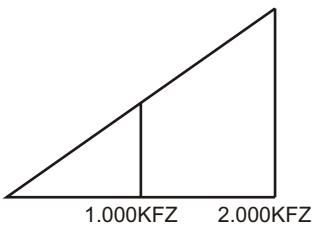
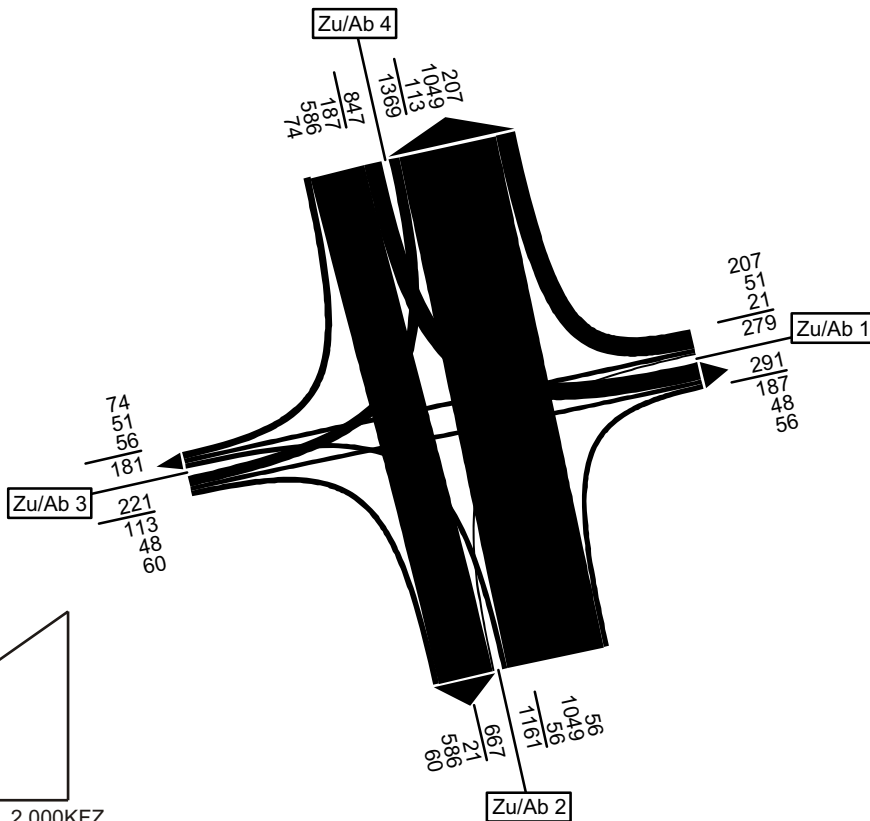

# Stadt Dachau

Zählstelle: K41 Freisinger Straße / Erich-Ollenauer-Straße

Zu-/Ablauf 1: Freisinger Str. (von/nach Stadtauswärts)

Zu-/Ablauf 2: Erich-Ollenauer-Str.

Zu-/Ablauf 3: Freisinger Str. (von/nach Stadteinwärts)

Zusammenfassung Stundengruppen

Zähltag: Do., 21.06.2007

Zählzeit: 06:00 Uhr - 10:00 Uhr und 15:00 Uhr - 19:00 Uhr

## Summe Zählzeit (06:00 Uhr - 10:00 Uhr und 15:00 Uhr - 19:00 Uhr)

FZ-ART	1-2	1-3	1-4	2-1	2-3	2-4	3-1	3-2	3-4	4-1	4-2	4-3	Zu. 1	Zu. 2	Zu. 3	Zu. 4	Ab. 1	Ab. 2	Ab. 3	Ab. 4	K-Sum
RAD	53	86	0	48	90	0	29	211	0	0	0	0	139	138	240	0	77	264	176	0	517
KRAD	43	46	0	40	33	0	48	46	0	0	0	0	89	73	94	0	88	89	79	0	256
PKW	1912	1858	0	1898	1332	0	1790	1582	0	0	0	0	3770	3230	3372	0	3688	3494	3190	0	10372
BUS	7	5	0	11	37	0	7	44	0	0	0	0	12	48	51	0	18	51	42	0	111
LFW	107	122	0	27	90	0	26	48	0	0	0	0	229	117	74	0	53	155	212	0	420
LKW	70	62	0	74	46	0	55	31	0	0	0	0	132	120	86	0	129	101	108	0	338
LZ	11	17	0	23	26	0	14	19	0	0	0	0	28	49	33	0	37	30	43	0	110
<b>KFZ</b>	<b>2150</b>	<b>2110</b>	<b>0</b>	<b>2073</b>	<b>1564</b>	<b>0</b>	<b>1940</b>	<b>1770</b>	<b>0</b>	<b>0</b>	<b>0</b>	<b>0</b>	<b>4260</b>	<b>3637</b>	<b>3710</b>	<b>0</b>	<b>4013</b>	<b>3920</b>	<b>3674</b>	<b>0</b>	<b>11607</b>
SV	88	84	0	108	109	0	76	94	0	0	0	0	172	217	170	0	184	182	193	0	559
PV	1962	1909	0	1949	1402	0	1845	1672	0	0	0	0	3871	3351	3517	0	3794	3634	3311	0	10739
GV	188	201	0	124	162	0	95	98	0	0	0	0	389	286	193	0	219	286	363	0	868
<b>FZ-ART</b>	<b>1-2</b>	<b>1-3</b>	<b>1-4</b>	<b>2-1</b>	<b>2-3</b>	<b>2-4</b>	<b>3-1</b>	<b>3-2</b>	<b>3-4</b>	<b>4-1</b>	<b>4-2</b>	<b>4-3</b>	<b>Zu. 1</b>	<b>Zu. 2</b>	<b>Zu. 3</b>	<b>Zu. 4</b>	<b>Ab. 1</b>	<b>Ab. 2</b>	<b>Ab. 3</b>	<b>Ab. 4</b>	<b>K-Sum</b>

## Summe Zählintervall 06:00 Uhr - 10:00 Uhr

FZ-ART	1-2	1-3	1-4	2-1	2-3	2-4	3-1	3-2	3-4	4-1	4-2	4-3	Zu. 1	Zu. 2	Zu. 3	Zu. 4	Ab. 1	Ab. 2	Ab. 3	Ab. 4	K-Sum
RAD	26	47	0	13	23	0	12	113	0	0	0	0	73	36	125	0	25	139	70	0	234
KRAD	34	19	0	8	7	0	10	24	0	0	0	0	53	15	34	0	18	58	26	0	102
PKW	1139	972	0	439	459	0	591	628	0	0	0	0	2111	898	1219	0	1030	1767	1431	0	4228
BUS	4	5	0	7	21	0	3	28	0	0	0	0	9	28	31	0	10	32	26	0	68
LFW	79	66	0	12	51	0	15	28	0	0	0	0	145	63	43	0	27	107	117	0	251
LKW	50	38	0	39	32	0	37	23	0	0	0	0	88	71	60	0	76	73	70	0	219
LZ	7	7	0	13	18	0	5	12	0	0	0	0	14	31	17	0	18	19	25	0	62
<b>KFZ</b>	<b>1313</b>	<b>1107</b>	<b>0</b>	<b>518</b>	<b>588</b>	<b>0</b>	<b>661</b>	<b>743</b>	<b>0</b>	<b>0</b>	<b>0</b>	<b>0</b>	<b>2420</b>	<b>1106</b>	<b>1404</b>	<b>0</b>	<b>1179</b>	<b>2056</b>	<b>1695</b>	<b>0</b>	<b>4930</b>
SV	61	50	0	59	71	0	45	63	0	0	0	0	111	130	108	0	104	124	121	0	349
PV	1177	996	0	454	487	0	604	680	0	0	0	0	2173	941	1284	0	1058	1857	1483	0	4398
GV	136	111	0	64	101	0	57	63	0	0	0	0	247	165	120	0	121	199	212	0	532
<b>FZ-ART</b>	<b>1-2</b>	<b>1-3</b>	<b>1-4</b>	<b>2-1</b>	<b>2-3</b>	<b>2-4</b>	<b>3-1</b>	<b>3-2</b>	<b>3-4</b>	<b>4-1</b>	<b>4-2</b>	<b>4-3</b>	<b>Zu. 1</b>	<b>Zu. 2</b>	<b>Zu. 3</b>	<b>Zu. 4</b>	<b>Ab. 1</b>	<b>Ab. 2</b>	<b>Ab. 3</b>	<b>Ab. 4</b>	<b>K-Sum</b>

## Summe Zählintervall 15:00 Uhr - 19:00 Uhr

FZ-ART	1-2	1-3	1-4	2-1	2-3	2-4	3-1	3-2	3-4	4-1	4-2	4-3	Zu. 1	Zu. 2	Zu. 3	Zu. 4	Ab. 1	Ab. 2	Ab. 3	Ab. 4	K-Sum
RAD	27	39	0	35	67	0	17	98	0	0	0	0	66	102	115	0	52	125	106	0	283
KRAD	9	27	0	32	26	0	38	22	0	0	0	0	36	58	60	0	70	31	53	0	154
PKW	773	886	0	1459	873	0	1199	954	0	0	0	0	1659	2332	2153	0	2658	1727	1759	0	6144
BUS	3	0	0	4	16	0	4	16	0	0	0	0	3	20	20	0	8	19	16	0	43
LFW	28	56	0	15	39	0	11	20	0	0	0	0	84	54	31	0	26	48	95	0	169
LKW	20	24	0	35	14	0	18	8	0	0	0	0	44	49	26	0	53	28	38	0	119
LZ	4	10	0	10	8	0	9	7	0	0	0	0	14	18	16	0	19	11	18	0	48
<b>KFZ</b>	<b>837</b>	<b>1003</b>	<b>0</b>	<b>1555</b>	<b>976</b>	<b>0</b>	<b>1279</b>	<b>1027</b>	<b>0</b>	<b>0</b>	<b>0</b>	<b>0</b>	<b>1840</b>	<b>2531</b>	<b>2306</b>	<b>0</b>	<b>2834</b>	<b>1864</b>	<b>1979</b>	<b>0</b>	<b>6677</b>
SV	27	34	0	49	38	0	31	31	0	0	0	0	61	87	62	0	80	58	72	0	210
PV	785	913	0	1495	915	0	1241	992	0	0	0	0	1698	2410	2233	0	2736	1777	1828	0	6341
GV	52	90	0	60	61	0	38	35	0	0	0	0	142	121	73	0	98	87	151	0	336
<b>FZ-ART</b>	<b>1-2</b>	<b>1-3</b>	<b>1-4</b>	<b>2-1</b>	<b>2-3</b>	<b>2-4</b>	<b>3-1</b>	<b>3-2</b>	<b>3-4</b>	<b>4-1</b>	<b>4-2</b>	<b>4-3</b>	<b>Zu. 1</b>	<b>Zu. 2</b>	<b>Zu. 3</b>	<b>Zu. 4</b>	<b>Ab. 1</b>	<b>Ab. 2</b>	<b>Ab. 3</b>	<b>Ab. 4</b>	<b>K-Sum</b>

## spezifische Spitzenstunde morgens 07:00 Uhr - 08:00 Uhr

FZ-ART	1-2	1-3	1-4	2-1	2-3	2-4	3-1	3-2	3-4	4-1	4-2	4-3	Zu. 1	Zu. 2	Zu. 3	Zu. 4	Ab. 1	Ab. 2	Ab. 3	Ab. 4	K-Sum
RAD	19	20	0	4	4	0	5	86	0	0	0	0	39	8	91	0	9	105	24	0	138
KRAD	22	8	0	2	4	0	3	18	0	0	0	0	30	6	21	0	5	40	12	0	57
PKW	334	351	0	133	120	0	180	161	0	0	0	0	685	253	341	0	313	495	471	0	1279
BUS	2	3	0	6	9	0	1	17	0	0	0	0	5	15	18	0	7	19	12	0	38
LFW	23	21	0	7	17	0	3	6	0	0	0	0	44	24	9	0	10	29	38	0	77
LKW	12	8	0	7	10	0	7	5	0	0	0	0	20	17	12	0	14	17	18	0	49
LZ	2	0	0	1	10	0	3	5	0	0	0	0	2	11	8	0	4	7	10	0	21
<b>KFZ</b>	<b>395</b>	<b>391</b>	<b>0</b>	<b>156</b>	<b>170</b>	<b>0</b>	<b>197</b>	<b>212</b>	<b>0</b>	<b>0</b>	<b>0</b>	<b>0</b>	<b>786</b>	<b>326</b>	<b>409</b>	<b>0</b>	<b>353</b>	<b>607</b>	<b>561</b>	<b>0</b>	<b>1521</b>
SV	16	11	0	14	29	0	11	27	0	0	0	0	27	43	38	0	25	43	40	0	108
PV	358	362	0	141	133	0	184	196	0	0	0	0	720	274	380	0	325	554	495	0	1374
GV	37	29	0	15	37	0	13	16	0	0	0	0	66	52	29	0	28	53	66	0	147
<b>FZ-ART</b>	<b>1-2</b>	<b>1-3</b>	<b>1-4</b>	<b>2-1</b>	<b>2-3</b>	<b>2-4</b>	<b>3-1</b>	<b>3-2</b>	<b>3-4</b>	<b>4-1</b>	<b>4-2</b>	<b>4-3</b>	<b>Zu. 1</b>	<b>Zu. 2</b>	<b>Zu. 3</b>	<b>Zu. 4</b>	<b>Ab. 1</b>	<b>Ab. 2</b>	<b>Ab. 3</b>	<b>Ab. 4</b>	<b>K-Sum</b>

## spezifische Spitzenstunde abends 17:00 Uhr - 18:00 Uhr

FZ-ART	1-2	1-3	1-4	2-1	2-3	2-4	3-1	3-2	3-4	4-1	4-2	4-3	Zu. 1	Zu. 2	Zu. 3	Zu. 4	Ab. 1	Ab. 2	Ab. 3	Ab. 4	K-Sum
RAD	13	15	0	3	6	0	3	32	0	0	0	0	28	9	35	0	6	45	21	0	72
KRAD	2	7	0	8	11	0	7	9	0	0	0	0	9	19	16	0	15	11	18	0	44
PKW	189	275	0	428	249	0	332	235	0	0	0	0	464	677	567	0	760	424	524	0	1708
BUS	0	0	0	0	5	0	0	2	0	0	0	0	0	5	2	0	0	2	5	0	7
LFW	8	18	0	5	4	0	2	5	0	0	0	0	26	9	7	0	7				

# Stadt Dachau

Zählstelle: K41 Freisinger Straße / Erich-Ollenhauer-Straße

Zusammenfassung Stundengruppen

Zähltag: Do., 21.06.2007

Zu-/Ablauf 1: Freisinger Str. (von/nach Stadtauswärts)

Zu-/Ablauf 2: Erich-Ollenhauer-Str.

Zu-/Ablauf 3: Freisinger Str. (von/nach Stadteinwärts)

Spezifische Spitzenstunde morgens  
07:00 Uhr - 08:00 Uhr in KFZ

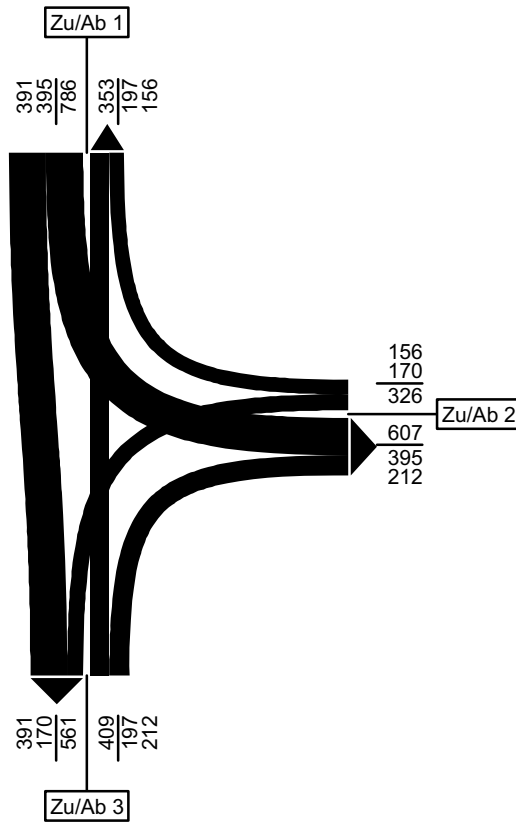

Spezifische Spitzenstunde abends  
17:00 Uhr - 18:00 Uhr in KFZ

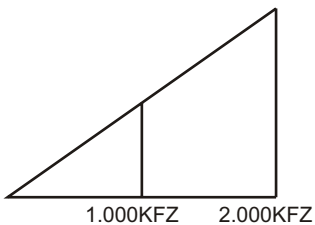
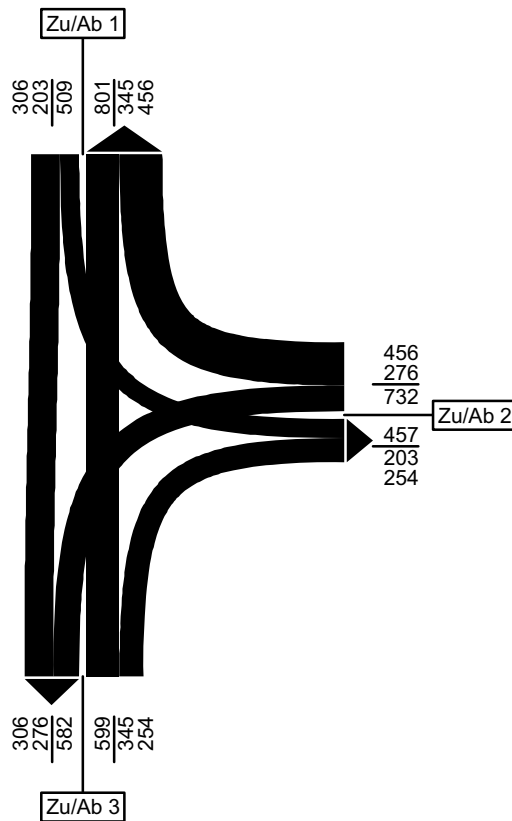

# Stadt Dachau

Zählstelle: K42 Augsburg Str. / Bürgermeister-Zauner-Ring

Zu-/Ablauf 1: Augsburg Str. (von/nach Stadtinwärts)

Zu-/Ablauf 2: Bürgermeister-Zauner-Ring

Zu-/Ablauf 3: Augsburg Str. (von/nach Stadtauswärts)

Zusammenfassung Stundengruppen

Zähltag: Do., 21.06.2007

Zählzeit: 06:00 Uhr - 10:00 Uhr und 15:00 Uhr - 19:00 Uhr

## Summe Zählzeit (06:00 Uhr - 10:00 Uhr und 15:00 Uhr - 19:00 Uhr)

FZ-ART	1-2	1-3	1-4	2-1	2-3	2-4	3-1	3-2	3-4	4-1	4-2	4-3	Zu. 1	Zu. 2	Zu. 3	Zu. 4	Ab. 1	Ab. 2	Ab. 3	Ab. 4	K-Sum
RAD	30	3	0	40	7	0	2	22	0	0	0	0	33	47	24	0	42	52	10	0	104
KRAD	31	36	0	24	37	0	44	40	0	0	0	0	67	61	84	0	68	71	73	0	212
PKW	1680	1770	0	1416	2156	0	2181	2281	0	0	0	0	3450	3572	4462	0	3597	3961	3926	0	11484
BUS	13	19	0	19	25	0	17	28	0	0	0	0	32	44	45	0	36	41	44	0	121
LFW	109	138	0	123	178	0	120	145	0	0	0	0	247	301	265	0	243	254	316	0	813
LKW	61	30	0	43	59	0	43	83	0	0	0	0	91	102	126	0	86	144	89	0	319
LZ	23	17	0	22	55	0	19	45	0	0	0	0	40	77	64	0	41	68	72	0	181
<b>KFZ</b>	<b>1917</b>	<b>2010</b>	<b>0</b>	<b>1647</b>	<b>2510</b>	<b>0</b>	<b>2424</b>	<b>2622</b>	<b>0</b>	<b>0</b>	<b>0</b>	<b>0</b>	<b>3927</b>	<b>4157</b>	<b>5046</b>	<b>0</b>	<b>4071</b>	<b>4539</b>	<b>4520</b>	<b>0</b>	<b>13130</b>
SV	97	66	0	84	139	0	79	156	0	0	0	0	163	223	235	0	163	253	205	0	621
PV	1724	1825	0	1459	2218	0	2242	2349	0	0	0	0	3549	3677	4591	0	3701	4073	4043	0	11817
GV	193	185	0	188	292	0	182	273	0	0	0	0	378	480	455	0	370	466	477	0	1313
<b>FZ-ART</b>	<b>1-2</b>	<b>1-3</b>	<b>1-4</b>	<b>2-1</b>	<b>2-3</b>	<b>2-4</b>	<b>3-1</b>	<b>3-2</b>	<b>3-4</b>	<b>4-1</b>	<b>4-2</b>	<b>4-3</b>	<b>Zu. 1</b>	<b>Zu. 2</b>	<b>Zu. 3</b>	<b>Zu. 4</b>	<b>Ab. 1</b>	<b>Ab. 2</b>	<b>Ab. 3</b>	<b>Ab. 4</b>	<b>K-Sum</b>

## Summe Zählintervall 06:00 Uhr - 10:00 Uhr

FZ-ART	1-2	1-3	1-4	2-1	2-3	2-4	3-1	3-2	3-4	4-1	4-2	4-3	Zu. 1	Zu. 2	Zu. 3	Zu. 4	Ab. 1	Ab. 2	Ab. 3	Ab. 4	K-Sum
RAD	11	3	0	29	6	0	0	5	0	0	0	0	14	35	5	0	29	16	9	0	54
KRAD	5	3	0	11	9	0	28	19	0	0	0	0	8	20	47	0	39	24	12	0	75
PKW	584	433	0	682	613	0	1489	1361	0	0	0	0	1017	1295	2850	0	2171	1945	1046	0	5162
BUS	6	10	0	14	14	0	15	15	0	0	0	0	16	28	30	0	29	21	24	0	74
LFW	66	49	0	64	83	0	85	96	0	0	0	0	115	147	181	0	149	162	132	0	443
LKW	36	19	0	34	33	0	31	52	0	0	0	0	55	67	83	0	65	88	52	0	205
LZ	12	8	0	15	26	0	12	23	0	0	0	0	20	41	35	0	27	35	34	0	96
<b>KFZ</b>	<b>709</b>	<b>522</b>	<b>0</b>	<b>820</b>	<b>778</b>	<b>0</b>	<b>1660</b>	<b>1566</b>	<b>0</b>	<b>0</b>	<b>0</b>	<b>0</b>	<b>1231</b>	<b>1598</b>	<b>3226</b>	<b>0</b>	<b>2480</b>	<b>2275</b>	<b>1300</b>	<b>0</b>	<b>6055</b>
SV	54	37	0	63	73	0	58	90	0	0	0	0	91	136	148	0	121	144	110	0	375
PV	595	446	0	707	636	0	1532	1395	0	0	0	0	1041	1343	2927	0	2239	1990	1082	0	5311
GV	114	76	0	113	142	0	128	171	0	0	0	0	190	255	299	0	241	285	218	0	744
<b>FZ-ART</b>	<b>1-2</b>	<b>1-3</b>	<b>1-4</b>	<b>2-1</b>	<b>2-3</b>	<b>2-4</b>	<b>3-1</b>	<b>3-2</b>	<b>3-4</b>	<b>4-1</b>	<b>4-2</b>	<b>4-3</b>	<b>Zu. 1</b>	<b>Zu. 2</b>	<b>Zu. 3</b>	<b>Zu. 4</b>	<b>Ab. 1</b>	<b>Ab. 2</b>	<b>Ab. 3</b>	<b>Ab. 4</b>	<b>K-Sum</b>

## Summe Zählintervall 15:00 Uhr - 19:00 Uhr

FZ-ART	1-2	1-3	1-4	2-1	2-3	2-4	3-1	3-2	3-4	4-1	4-2	4-3	Zu. 1	Zu. 2	Zu. 3	Zu. 4	Ab. 1	Ab. 2	Ab. 3	Ab. 4	K-Sum
RAD	19	0	0	11	1	0	2	17	0	0	0	0	19	12	19	0	13	36	1	0	50
KRAD	26	33	0	13	28	0	16	21	0	0	0	0	59	41	37	0	29	47	61	0	137
PKW	1096	1337	0	734	1543	0	692	920	0	0	0	0	2433	2277	1612	0	1426	2016	2880	0	6322
BUS	7	9	0	5	11	0	2	13	0	0	0	0	16	16	15	0	7	20	20	0	47
LFW	43	89	0	59	95	0	35	49	0	0	0	0	132	154	84	0	94	92	184	0	370
LKW	25	11	0	9	26	0	12	31	0	0	0	0	36	35	43	0	21	56	37	0	114
LZ	11	9	0	7	29	0	7	22	0	0	0	0	20	36	29	0	14	33	38	0	85
<b>KFZ</b>	<b>1208</b>	<b>1488</b>	<b>0</b>	<b>827</b>	<b>1732</b>	<b>0</b>	<b>764</b>	<b>1056</b>	<b>0</b>	<b>0</b>	<b>0</b>	<b>0</b>	<b>2696</b>	<b>2559</b>	<b>1820</b>	<b>0</b>	<b>1591</b>	<b>2264</b>	<b>3220</b>	<b>0</b>	<b>7075</b>
SV	43	29	0	21	66	0	21	66	0	0	0	0	72	87	87	0	42	109	95	0	246
PV	1129	1379	0	752	1582	0	710	954	0	0	0	0	2508	2334	1664	0	1462	2083	2961	0	6506
GV	79	109	0	75	150	0	54	102	0	0	0	0	188	225	156	0	129	181	259	0	569
<b>FZ-ART</b>	<b>1-2</b>	<b>1-3</b>	<b>1-4</b>	<b>2-1</b>	<b>2-3</b>	<b>2-4</b>	<b>3-1</b>	<b>3-2</b>	<b>3-4</b>	<b>4-1</b>	<b>4-2</b>	<b>4-3</b>	<b>Zu. 1</b>	<b>Zu. 2</b>	<b>Zu. 3</b>	<b>Zu. 4</b>	<b>Ab. 1</b>	<b>Ab. 2</b>	<b>Ab. 3</b>	<b>Ab. 4</b>	<b>K-Sum</b>

## spezifische Spitzenstunde morgens 07:15 Uhr - 08:15 Uhr

FZ-ART	1-2	1-3	1-4	2-1	2-3	2-4	3-1	3-2	3-4	4-1	4-2	4-3	Zu. 1	Zu. 2	Zu. 3	Zu. 4	Ab. 1	Ab. 2	Ab. 3	Ab. 4	K-Sum
RAD	4	1	0	22	5	0	0	0	0	0	0	0	5	27	0	0	22	4	6	0	32
KRAD	1	1	0	4	1	0	6	8	0	0	0	0	2	5	14	0	10	9	2	0	21
PKW	196	111	0	181	203	0	464	454	0	0	0	0	307	384	918	0	645	650	314	0	1609
BUS	3	2	0	8	4	0	6	5	0	0	0	0	5	12	11	0	14	8	6	0	28
LFW	19	16	0	16	26	0	19	24	0	0	0	0	35	42	43	0	35	43	42	0	120
LKW	9	6	0	8	12	0	6	15	0	0	0	0	15	20	21	0	14	24	18	0	56
LZ	3	2	0	2	10	0	5	4	0	0	0	0	5	12	9	0	7	7	12	0	26
<b>KFZ</b>	<b>231</b>	<b>138</b>	<b>0</b>	<b>219</b>	<b>256</b>	<b>0</b>	<b>506</b>	<b>510</b>	<b>0</b>	<b>0</b>	<b>0</b>	<b>0</b>	<b>369</b>	<b>475</b>	<b>1016</b>	<b>0</b>	<b>725</b>	<b>741</b>	<b>394</b>	<b>0</b>	<b>1860</b>
SV	15	10	0	18	26	0	17	24	0	0	0	0	25	44	41	0	35	39	36	0	110
PV	200	114	0	193	208	0	476	467	0	0	0	0	314	401	943	0	669	667	322	0	1658
GV	31	24	0	26	48	0	30	43	0	0	0	0	55	74	73	0	56	74	72	0	202
<b>FZ-ART</b>	<b>1-2</b>	<b>1-3</b>	<b>1-4</b>	<b>2-1</b>	<b>2-3</b>	<b>2-4</b>	<b>3-1</b>	<b>3-2</b>	<b>3-4</b>	<b>4-1</b>	<b>4-2</b>	<b>4-3</b>	<b>Zu. 1</b>	<b>Zu. 2</b>	<b>Zu. 3</b>	<b>Zu. 4</b>	<b>Ab. 1</b>	<b>Ab. 2</b>	<b>Ab. 3</b>	<b>Ab. 4</b>	<b>K-Sum</b>

## spezifische Spitzenstunde abends 16:30 Uhr - 17:30 Uhr

FZ-ART	1-2	1-3	1-4	2-1	2-3	2-4	3-1	3-2	3-4	4-1	4-2	4-3	Zu. 1	Zu. 2	Zu. 3	Zu. 4	Ab. 1	Ab. 2	Ab. 3	Ab. 4	K-Sum
RAD	8	0	0	2	0	0	0	7	0	0	0	0	8	2	7	0	2	15	0	0	17
KRAD	7	3	0	7	8	0	4	6	0	0	0	0	10	15	10	0	11	13	11	0	35
PKW	331	284	0	184	421	0	182	251	0	0	0	0	615	605	433	0	366	582	705	0	1663
BUS	4	2	0	0	4	0	1	4	0	0	0	0	6	4	5	0	1	8	6	0	15
LFW	13	26	0	16	38	0	8	11	0	0	0	0	39	54	19	0	24	24			

# Stadt Dachau

Zählstelle: K42 Augsburgere Straße / Bürgermeister-Zauner-Ring

Zusammenfassung Stundengruppen

Zähltag: Do., 21.06.2007

Zu-/Ablauf 1: Augsburgere Str. (von/nach Stadteinwärts)

Zu-/Ablauf 2: Bürgermeister-Zauner-Ring

Zu-/Ablauf 3: Augsburgere Str. (von/nach Stadtauswärts)

Spezifische Spitzenstunde morgens  
07:15 Uhr - 08:15 Uhr in KFZ

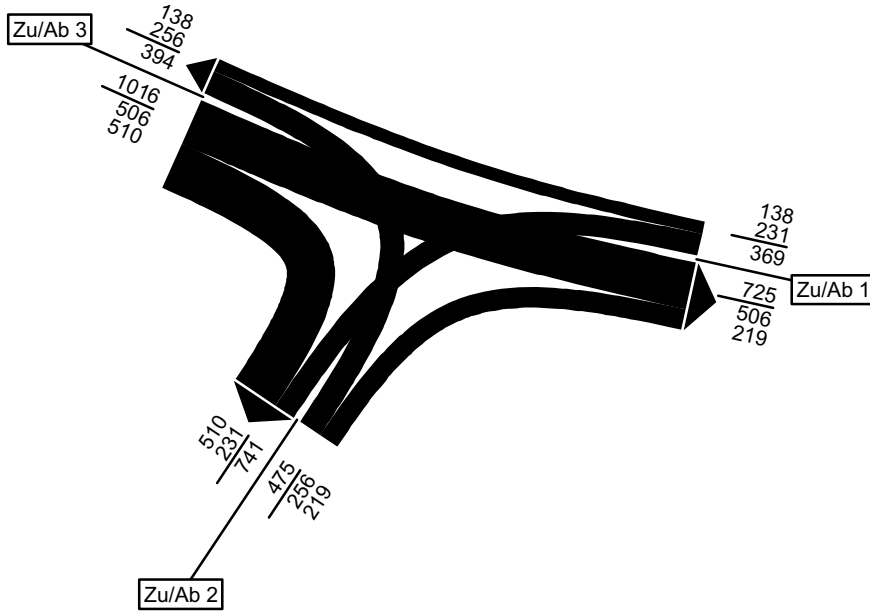

Spezifische Spitzenstunde abends  
16:30 Uhr - 17:30 Uhr in KFZ

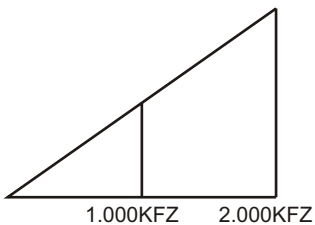
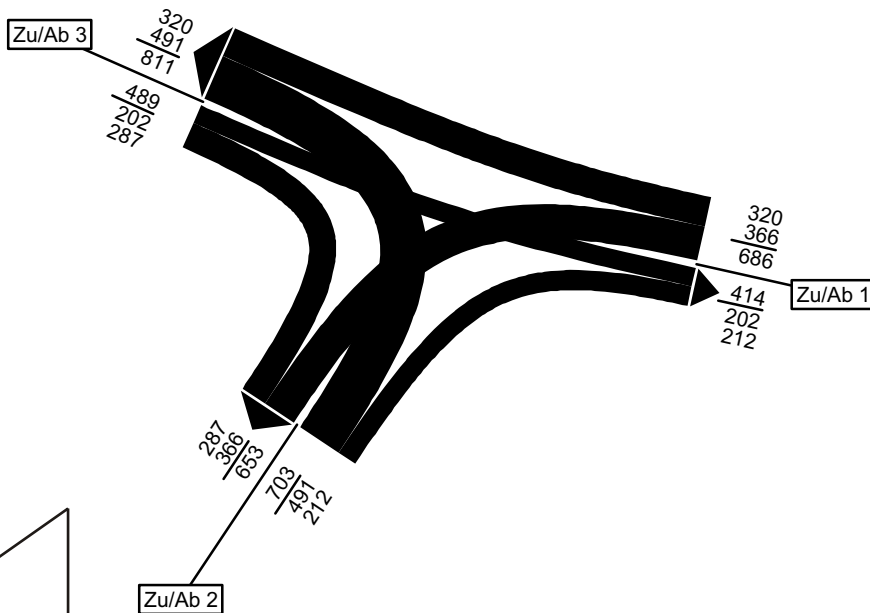

# Stadt Dachau

Zählstelle: K43 Theodor-Heuss-Straße / Schleißheimer Straße

Zu-/Ablauf 1: Theodor-Heuss-Str. (von/nach Norden)  
 Zu-/Ablauf 2: Schleißheimer Str. (von/nach Stadtauswärts)  
 Zu-/Ablauf 3: Theodor-Heuss-Str. (von/nach Süden)  
 Zu-/Ablauf 4: Schleißheimer Str. (von/nach Stadteinwärts)

Zusammenfassung Stundengruppen

Zähltag: Do., 26.10.2006  
 Zählzeit: 06:00 Uhr - 10:00 Uhr und 15:00 Uhr - 19:00 Uhr

## Summe Zählzeit (06:00 Uhr - 10:00 Uhr und 15:00 Uhr - 19:00 Uhr)

FZ-ART	1-2	1-3	1-4	2-1	2-3	2-4	3-1	3-2	3-4	4-1	4-2	4-3	Zu. 1	Zu. 2	Zu. 3	Zu. 4	Ab. 1	Ab. 2	Ab. 3	Ab. 4	K-Sum
RAD	31	122	40	1	43	58	91	17	1	2	163	22	193	102	109	187	94	211	187	99	591
KRAD	19	33	21	9	26	35	39	36	15	17	47	9	73	70	90	73	65	102	68	71	306
PKW	623	1923	769	503	1357	2130	1757	1355	629	716	2163	632	3315	3990	3741	3511	2976	4141	3912	3528	14557
BUS	16	2	0	3	0	28	5	8	1	3	46	3	18	31	14	52	11	70	5	29	115
LFW	57	90	45	19	66	143	61	112	51	18	136	34	192	228	224	188	98	305	190	239	832
LKW	46	60	6	30	60	46	71	71	20	7	40	10	112	136	162	57	108	157	130	72	467
LZ	12	21	1	13	21	13	6	20	2	2	9	2	34	47	28	13	21	41	44	16	122
<b>KFZ</b>	<b>773</b>	<b>2129</b>	<b>842</b>	<b>577</b>	<b>1530</b>	<b>2395</b>	<b>1939</b>	<b>1602</b>	<b>718</b>	<b>763</b>	<b>2441</b>	<b>690</b>	<b>3744</b>	<b>4502</b>	<b>4259</b>	<b>3894</b>	<b>3279</b>	<b>4816</b>	<b>4349</b>	<b>3955</b>	<b>16399</b>
SV	74	83	7	46	81	87	82	99	23	12	95	15	164	214	204	122	140	268	179	117	704
PV	658	1958	790	515	1383	2193	1801	1399	645	736	2256	644	3406	4091	3845	3636	3052	4313	3985	3628	14978
GV	115	171	52	62	147	202	138	203	73	27	185	46	338	411	414	258	227	503	364	327	1421
<b>FZ-ART</b>	<b>1-2</b>	<b>1-3</b>	<b>1-4</b>	<b>2-1</b>	<b>2-3</b>	<b>2-4</b>	<b>3-1</b>	<b>3-2</b>	<b>3-4</b>	<b>4-1</b>	<b>4-2</b>	<b>4-3</b>	<b>Zu. 1</b>	<b>Zu. 2</b>	<b>Zu. 3</b>	<b>Zu. 4</b>	<b>Ab. 1</b>	<b>Ab. 2</b>	<b>Ab. 3</b>	<b>Ab. 4</b>	<b>K-Sum</b>

## Summe Zählintervall 06:00 Uhr - 10:00 Uhr

FZ-ART	1-2	1-3	1-4	2-1	2-3	2-4	3-1	3-2	3-4	4-1	4-2	4-3	Zu. 1	Zu. 2	Zu. 3	Zu. 4	Ab. 1	Ab. 2	Ab. 3	Ab. 4	K-Sum
RAD	11	35	25	0	3	19	35	11	1	1	47	8	71	22	47	56	36	69	46	45	196
KRAD	11	16	6	4	8	5	6	14	1	3	19	5	33	17	21	27	13	44	29	12	98
PKW	311	1000	271	146	482	668	583	533	194	228	949	328	1582	1296	1310	1505	957	1793	1810	1133	5693
BUS	11	2	0	3	0	15	3	5	1	2	26	3	13	18	9	31	8	42	5	16	71
LFW	35	58	29	10	39	69	17	67	24	11	64	20	122	118	108	95	38	166	117	122	443
LKW	24	41	3	14	33	27	24	44	10	3	24	9	68	74	78	36	41	92	83	40	256
LZ	6	14	1	12	9	7	5	12	1	2	5	1	21	28	18	8	19	23	24	9	75
<b>KFZ</b>	<b>398</b>	<b>1131</b>	<b>310</b>	<b>189</b>	<b>571</b>	<b>791</b>	<b>638</b>	<b>675</b>	<b>231</b>	<b>249</b>	<b>1087</b>	<b>366</b>	<b>1839</b>	<b>1551</b>	<b>1544</b>	<b>1702</b>	<b>1076</b>	<b>2160</b>	<b>2068</b>	<b>1332</b>	<b>6636</b>
SV	41	57	4	29	42	49	32	61	12	7	55	13	102	120	105	75	68	157	112	65	402
PV	333	1018	277	153	490	688	592	552	196	233	994	336	1628	1331	1340	1563	978	1879	1844	1161	5862
GV	65	113	33	36	81	103	46	123	35	16	93	30	211	220	204	139	98	281	224	171	774
<b>FZ-ART</b>	<b>1-2</b>	<b>1-3</b>	<b>1-4</b>	<b>2-1</b>	<b>2-3</b>	<b>2-4</b>	<b>3-1</b>	<b>3-2</b>	<b>3-4</b>	<b>4-1</b>	<b>4-2</b>	<b>4-3</b>	<b>Zu. 1</b>	<b>Zu. 2</b>	<b>Zu. 3</b>	<b>Zu. 4</b>	<b>Ab. 1</b>	<b>Ab. 2</b>	<b>Ab. 3</b>	<b>Ab. 4</b>	<b>K-Sum</b>

## Summe Zählintervall 15:00 Uhr - 19:00 Uhr

FZ-ART	1-2	1-3	1-4	2-1	2-3	2-4	3-1	3-2	3-4	4-1	4-2	4-3	Zu. 1	Zu. 2	Zu. 3	Zu. 4	Ab. 1	Ab. 2	Ab. 3	Ab. 4	K-Sum
RAD	20	87	15	1	40	39	56	6	0	1	116	14	122	80	62	131	58	142	141	54	395
KRAD	8	17	15	5	18	30	33	22	14	14	28	4	40	53	69	46	52	58	39	59	208
PKW	312	923	498	357	875	1462	1174	822	435	488	1214	304	1733	2694	2431	2006	2019	2348	2102	2395	8864
BUS	5	0	0	0	13	2	3	0	1	20	0	0	5	13	5	21	3	28	0	13	44
LFW	22	32	16	9	27	74	44	45	27	7	72	14	70	110	116	93	60	139	73	117	389
LKW	22	19	3	16	27	19	47	27	10	4	16	1	44	62	84	21	67	65	47	32	211
LZ	6	7	0	1	12	6	1	8	1	0	4	1	13	19	10	5	2	18	20	7	47
<b>KFZ</b>	<b>375</b>	<b>998</b>	<b>532</b>	<b>388</b>	<b>959</b>	<b>1604</b>	<b>1301</b>	<b>927</b>	<b>487</b>	<b>514</b>	<b>1354</b>	<b>324</b>	<b>1905</b>	<b>2951</b>	<b>2715</b>	<b>2192</b>	<b>2203</b>	<b>2656</b>	<b>2281</b>	<b>2623</b>	<b>9763</b>
SV	33	26	3	17	39	38	50	38	11	5	40	2	62	94	99	47	72	111	67	52	302
PV	325	940	513	362	893	1505	1209	847	449	503	1262	308	1778	2760	2505	2073	2074	2434	2141	2467	9116
GV	50	58	19	26	66	99	92	80	38	11	92	16	127	191	210	119	129	222	140	156	647
<b>FZ-ART</b>	<b>1-2</b>	<b>1-3</b>	<b>1-4</b>	<b>2-1</b>	<b>2-3</b>	<b>2-4</b>	<b>3-1</b>	<b>3-2</b>	<b>3-4</b>	<b>4-1</b>	<b>4-2</b>	<b>4-3</b>	<b>Zu. 1</b>	<b>Zu. 2</b>	<b>Zu. 3</b>	<b>Zu. 4</b>	<b>Ab. 1</b>	<b>Ab. 2</b>	<b>Ab. 3</b>	<b>Ab. 4</b>	<b>K-Sum</b>

## spezifische Spitzenstunde morgens 07:15 Uhr - 08:15 Uhr

FZ-ART	1-2	1-3	1-4	2-1	2-3	2-4	3-1	3-2	3-4	4-1	4-2	4-3	Zu. 1	Zu. 2	Zu. 3	Zu. 4	Ab. 1	Ab. 2	Ab. 3	Ab. 4	K-Sum
RAD	5	14	15	0	2	8	13	2	0	0	13	4	34	10	15	17	13	20	20	23	76
KRAD	5	3	1	0	6	3	2	5	1	0	3	2	9	9	8	5	2	13	11	5	31
PKW	89	340	82	43	146	200	191	159	66	49	263	142	511	389	416	454	283	511	628	348	1770
BUS	2	1	0	0	0	6	3	0	0	1	10	3	3	6	3	14	4	12	4	6	26
LFW	10	22	5	0	14	23	8	21	7	4	27	7	37	37	36	38	12	58	43	35	148
LKW	7	13	2	2	7	7	15	11	2	1	8	2	22	16	28	11	18	26	22	11	77
LZ	3	6	0	2	2	4	3	4	1	1	1	0	9	8	8	2	6	8	8	5	27
<b>KFZ</b>	<b>116</b>	<b>385</b>	<b>90</b>	<b>47</b>	<b>175</b>	<b>243</b>	<b>222</b>	<b>200</b>	<b>77</b>	<b>56</b>	<b>312</b>	<b>156</b>	<b>591</b>	<b>465</b>	<b>499</b>	<b>524</b>	<b>325</b>	<b>628</b>	<b>716</b>	<b>410</b>	<b>2079</b>
SV	12	20	2	4	9	17	21	15	3	3	19	5	34	30	39	27	28	46	34	22	130
PV	96	344	83	43	152	209	196	164	67	50	276	147	523	404	427	473	289	536	643	359	1827
GV	20	41	7	4	23	34	26	36	10	6	36	9	68	61	72	51	36	92	73	51	252
<b>FZ-ART</b>	<b>1-2</b>	<b>1-3</b>	<b>1-4</b>	<b>2-1</b>	<b>2-3</b>	<b>2-4</b>	<b>3-1</b>	<b>3-2</b>	<b>3-4</b>	<b>4-1</b>	<b>4-2</b>	<b>4-3</b>	<b>Zu. 1</b>	<b>Zu. 2</b>	<b>Zu. 3</b>	<b>Zu. 4</b>	<b>Ab. 1</b>	<b>Ab. 2</b>	<b>Ab. 3</b>	<b>Ab. 4</b>	<b>K-Sum</b>

## spezifische Spitzenstunde abends 16:45 Uhr - 17:45 Uhr

FZ-ART	1-2	1-3	1-4	2-1	2-3	2-4	3-1	3-2	3-4	4-1	4-2	4-3	Zu. 1	Zu. 2	Zu. 3	Zu. 4	Ab. 1	Ab. 2	Ab. 3	Ab. 4	K-Sum
RAD	6	25	5	0	19	16	8	2	0	1	30	1	36	35	10	32	9	38	45	21	113
KRAD	2	7	8	3	7	9	9	5	2	8	7	1	17	19	16	16	20	14	15	19	68
PKW	69	266	164	132	273	404	336	241	100	154	333	86	499	809	677	573	622	643	625	668	2558



# Stadt Dachau

Zählstelle: K43 Theodor-Heuss-Straße / Schleißheimer Straße

Zusammenfassung Stundengruppen

Zähltag: Do., 26.10.2006

Zu-/Ablauf 1: Theodor-Heuss-Str. (von/nach Norden)  
 Zu-/Ablauf 2: Schleißheimer Str. (von/nach Stadtauswärts)  
 Zu-/Ablauf 3: Theodor-Heuss-Str. (von/nach Süden)  
 Zu-/Ablauf 4: Schleißheimer Str. (von/nach Stadteinwärts)

Spezifische Spitzenstunde morgens  
 07:15 Uhr - 08:15 Uhr in KFZ

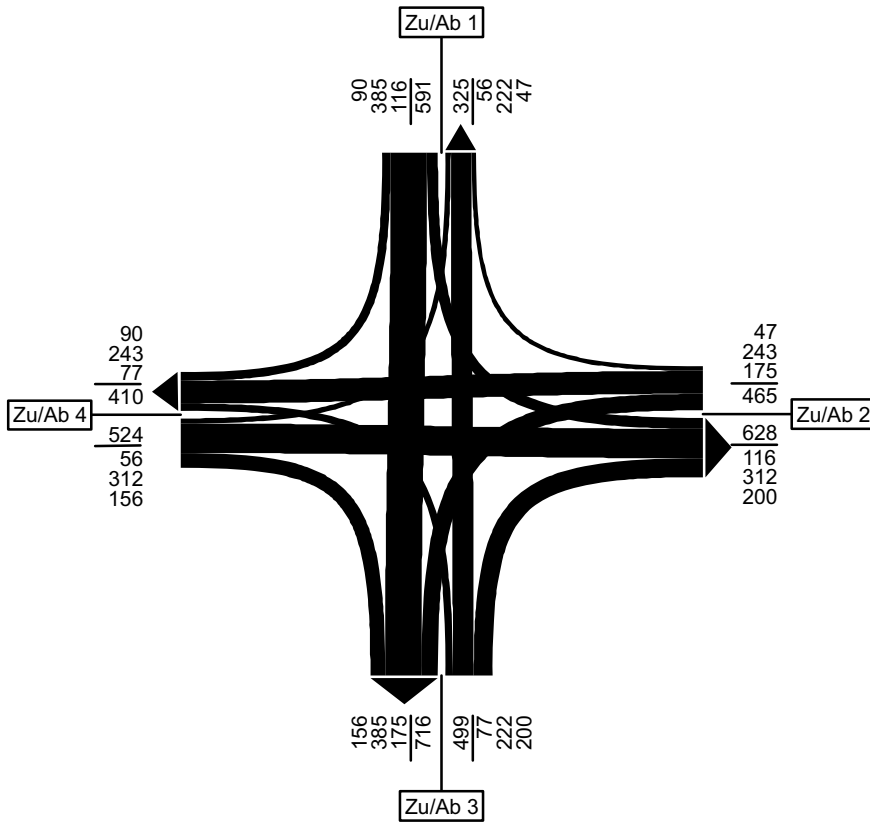

Spezifische Spitzenstunde abends  
 16:45 Uhr - 17:45 Uhr in KFZ

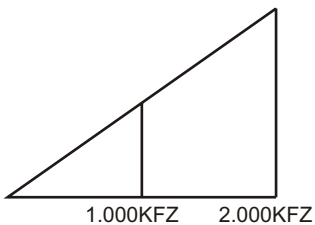
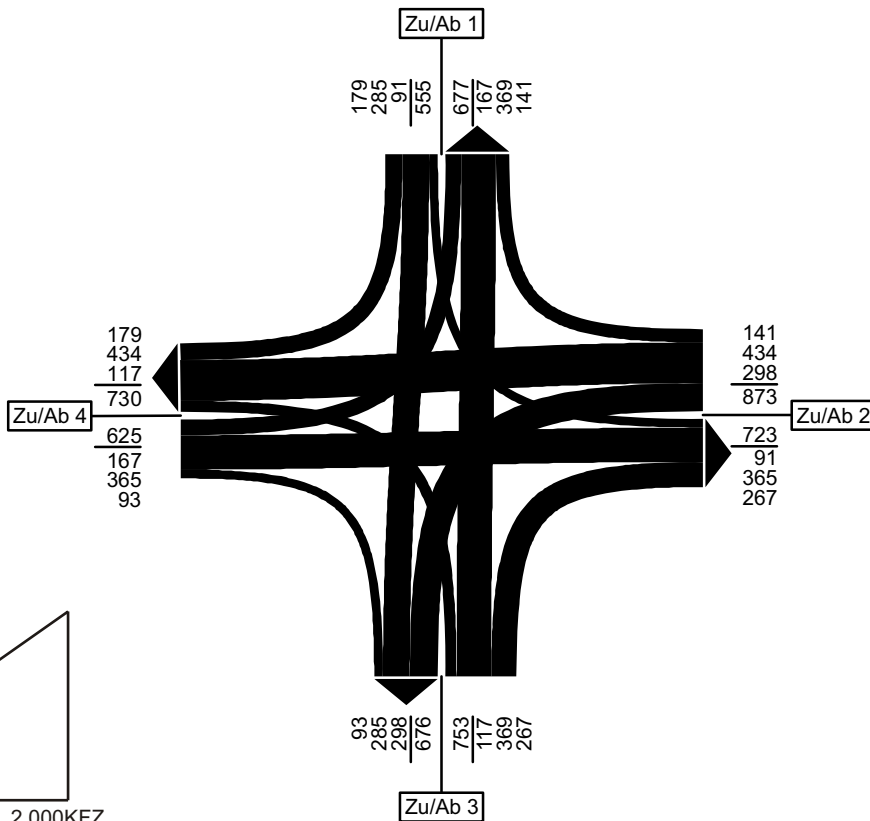



# Stadt Dachau

Zählstelle: K44 Schleißheimer Straße / Alte-Römer-Straße

Zusammenfassung Stundengruppen

Zähltag: Do., 26.10.2006

Zu-/Ablauf 1: Schleißheimer Str. (von/nach Stadtauswärts)

Zu-/Ablauf 2: Bajuwarenstr.

Zu-/Ablauf 3: Schleißheimer Str. (von/nach Stadteinwärts)

Zu-/Ablauf 4: Alte-Römer-Str.

Spezifische Spitzenstunde morgens  
07:15 Uhr - 08:15 Uhr in KFZ

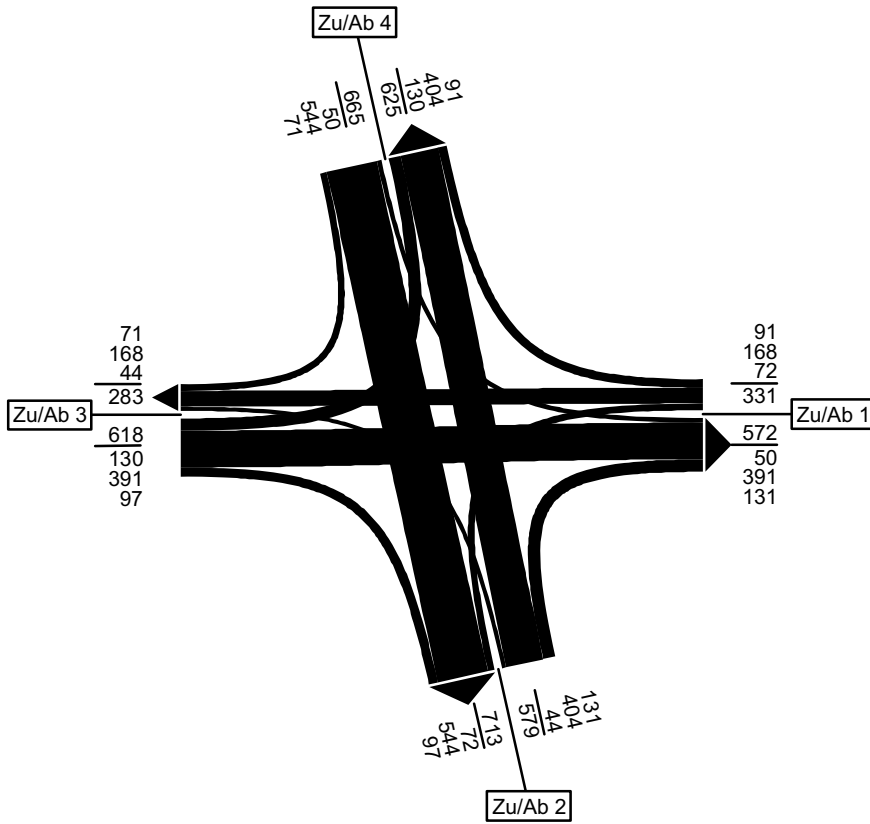

Spezifische Spitzenstunde abends  
16:15 Uhr - 17:15 Uhr in KFZ

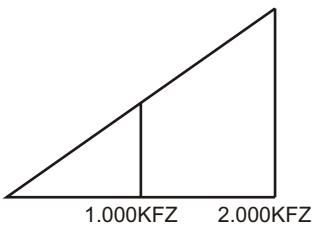
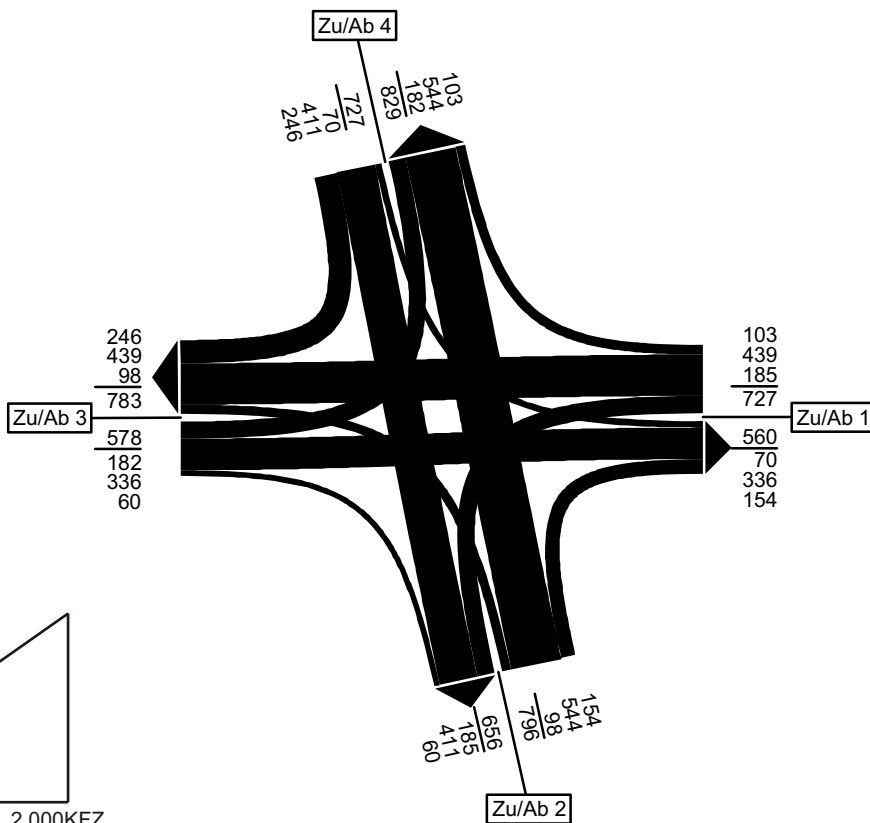



# Stadt Dachau

Zählstelle: K45 Ludwig-Thoma-Straße / Konrad-Adenauer-Straße

Zusammenfassung Stundengruppen

Zähltag: Do., 21.06.2007

Zu-/Ablauf 1: Konrad-Adenauer-Str. (von/nach Stadtauswärts)

Zu-/Ablauf 2: Ludwig-Thoma-Str. (von/nach Festwiese)

Zu-/Ablauf 3: Konrad-Adenauer-Str. (von/nach Altstadt)

Zu-/Ablauf 4: Ludwig-Thoma-Str. (von/nach Stadtauswärts)

Spezifische Spitzenstunde morgens  
07:15 Uhr - 08:15 Uhr in KFZ

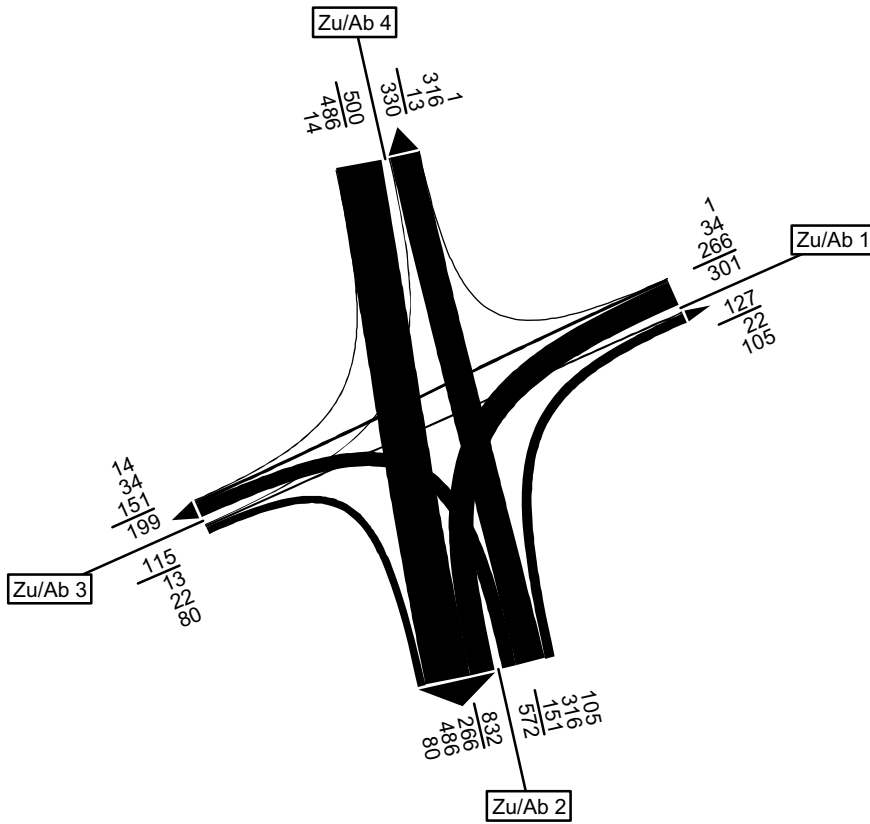

Spezifische Spitzenstunde abends  
15:45 Uhr - 16:45 Uhr in KFZ

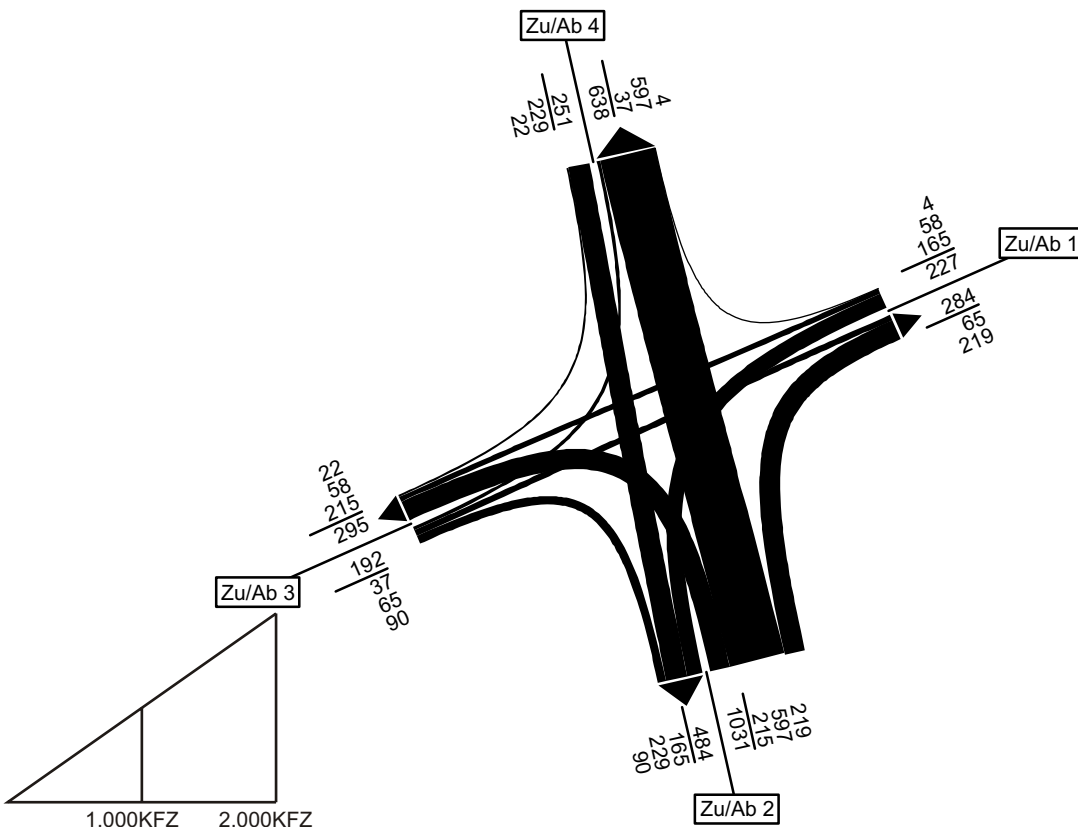

**Stadt Dachau**

Zählstelle: K46 Erich-Ollenhauer-Straße / Friedenstraße

Zusammenfassung Stundengruppen

Zu-/Ablauf 1: Sudetenlandstr.

Zu-/Ablauf 2: Friedenstr.

Zu-/Ablauf 3: Erich-Ollenhauer-Str.

Zähltag: Do., 21.06.2007

Zählzeit: 06:00 Uhr - 10:00 Uhr und 15:00 Uhr - 19:00 Uhr

**Summe Zähzeit (06:00 Uhr - 10:00 Uhr und 15:00 Uhr - 19:00 Uhr)**

Table with 24 columns (1-2, 1-3, 1-4, 2-1, 2-3, 2-4, 3-1, 3-2, 3-4, 4-1, 4-2, 4-3, Zu. 1, Zu. 2, Zu. 3, Zu. 4, Ab. 1, Ab. 2, Ab. 3, Ab. 4, K-Sum) and rows for FZ-ART, RAD, KRAD, PKW, BUS, LFW, LKW, LZ, KFZ, SV, PV, GV, and FZ-ART summary.

**Summe Zählintervall 06:00 Uhr - 10:00 Uhr**

Table with 24 columns (1-2, 1-3, 1-4, 2-1, 2-3, 2-4, 3-1, 3-2, 3-4, 4-1, 4-2, 4-3, Zu. 1, Zu. 2, Zu. 3, Zu. 4, Ab. 1, Ab. 2, Ab. 3, Ab. 4, K-Sum) and rows for FZ-ART, RAD, KRAD, PKW, BUS, LFW, LKW, LZ, KFZ, SV, PV, GV, and FZ-ART summary.

**Summe Zählintervall 15:00 Uhr - 19:00 Uhr**

Table with 24 columns (1-2, 1-3, 1-4, 2-1, 2-3, 2-4, 3-1, 3-2, 3-4, 4-1, 4-2, 4-3, Zu. 1, Zu. 2, Zu. 3, Zu. 4, Ab. 1, Ab. 2, Ab. 3, Ab. 4, K-Sum) and rows for FZ-ART, RAD, KRAD, PKW, BUS, LFW, LKW, LZ, KFZ, SV, PV, GV, and FZ-ART summary.

**spezifische Spitzenstunde morgens 07:00 Uhr - 08:00 Uhr**

Table with 24 columns (1-2, 1-3, 1-4, 2-1, 2-3, 2-4, 3-1, 3-2, 3-4, 4-1, 4-2, 4-3, Zu. 1, Zu. 2, Zu. 3, Zu. 4, Ab. 1, Ab. 2, Ab. 3, Ab. 4, K-Sum) and rows for FZ-ART, RAD, KRAD, PKW, BUS, LFW, LKW, LZ, KFZ, SV, PV, GV, and FZ-ART summary.

**spezifische Spitzenstunde abends 17:00 Uhr - 18:00 Uhr**

Table with 24 columns (1-2, 1-3, 1-4, 2-1, 2-3, 2-4, 3-1, 3-2, 3-4, 4-1, 4-2, 4-3, Zu. 1, Zu. 2, Zu. 3, Zu. 4, Ab. 1, Ab. 2, Ab. 3, Ab. 4, K-Sum) and rows for FZ-ART, RAD, KRAD, PKW, BUS, LFW, LKW, LZ, KFZ, SV, PV, GV, and FZ-ART summary.

**Erläuterungen:**

RAD = Fahrrad

KRAD = Kraftrad

PKW = Personenkraftwagen

BUS = Linien-/ Reisebus (mehr als 9 Insassen)

LFW = Lieferwagen

LKW = Lastkraftwagen (> 2.8t)

LZ = Lastzug / Sonderfahrzeuge

KFZ = Kraftfahrzeuge (KRAD+PKW+BUS+LFW+LKW+LZ)

SV = Schwerverkehr (BUS+LKW+LZ)

PV = Personenverkehr (KRAD+PKW+BUS)

GV = Güterverkehr (LFW+LKW+LZ)

# Stadt Dachau

Zählstelle: K46 Erich-Ollenhauer-Straße / Friedenstraße

Zusammenfassung Stundengruppen

Zähltag: Do., 21.06.2007

Zu-/Ablauf 1: Sudetenlandstr.

Zu-/Ablauf 2: Friedenstr.

Zu-/Ablauf 3: Erich-Ollenhauer-Str.

Spezifische Spitzenstunde morgens  
07:00 Uhr - 08:00 Uhr in KFZ

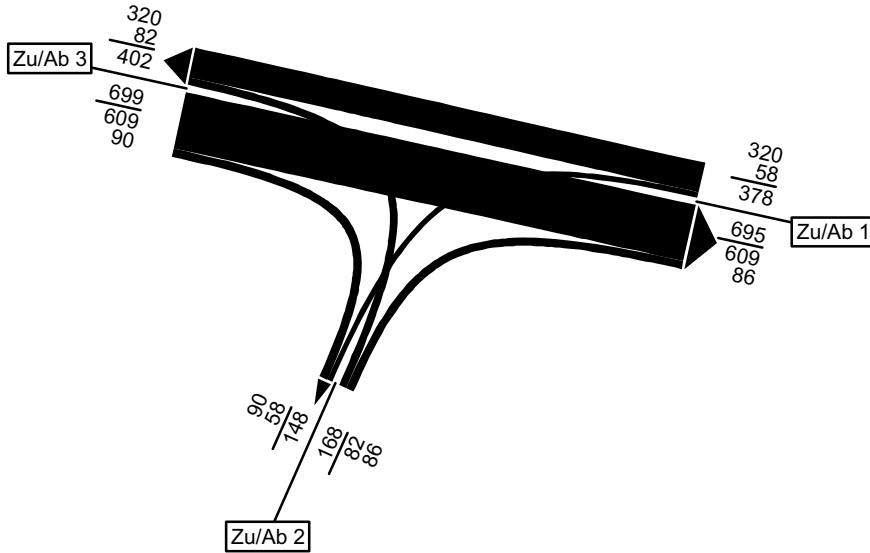

Spezifische Spitzenstunde abends  
17:00 Uhr - 18:00 Uhr in KFZ

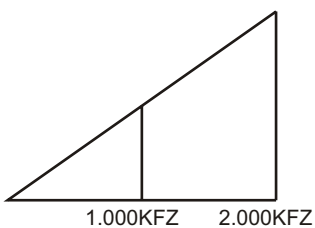
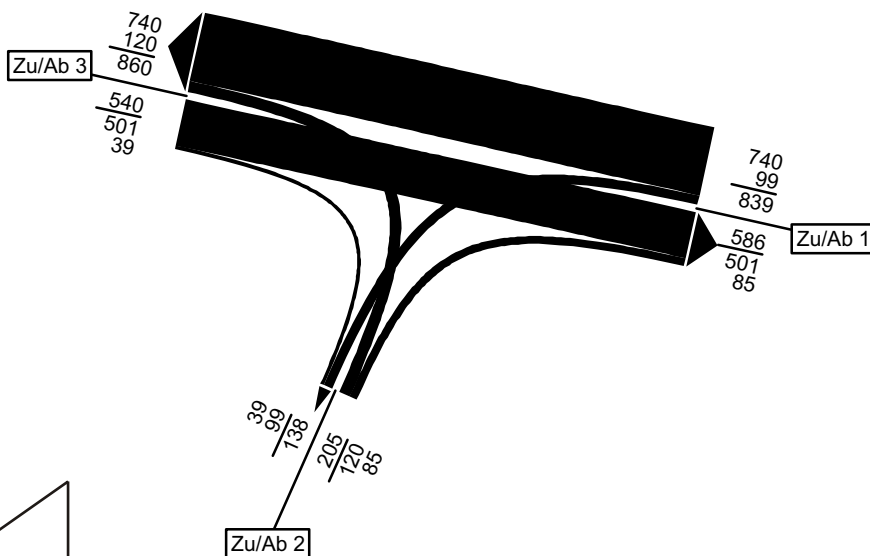





# Stadt Dachau

Zählstelle: K47 Brucker Straße / Ludwig-Dill-Straße

Zusammenfassung Stundengruppen

Zähltag: Do., 21.06.2007

Zu-/Ablauf 1: Brucker Str. (von/nach Stadteinwärts)

Zu-/Ablauf 2: Ludwig-Dill-Str.

Zu-/Ablauf 3: Brucker Str. (von/nach Stadtauswärts)

Spezifische Spitzenstunde morgens  
07:15 Uhr - 08:15 Uhr in KFZ

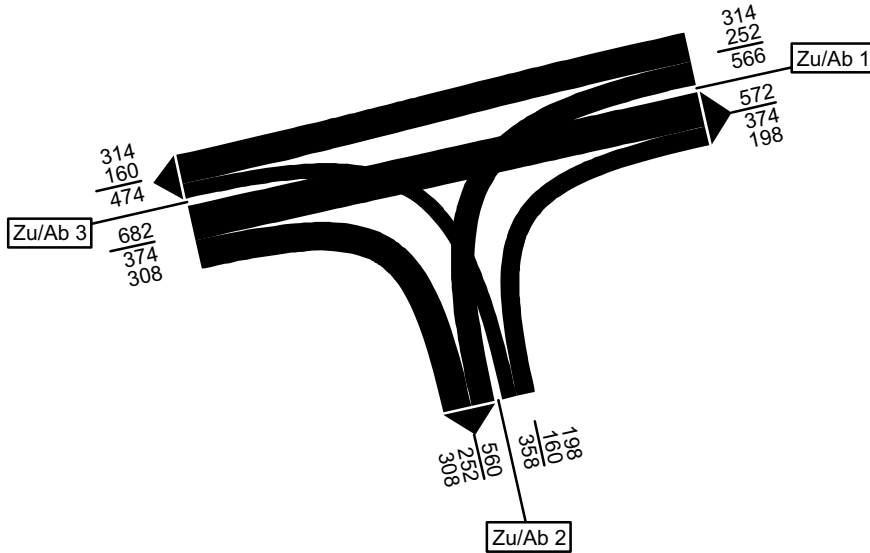

Spezifische Spitzenstunde abends  
17:00 Uhr - 18:00 Uhr in KFZ

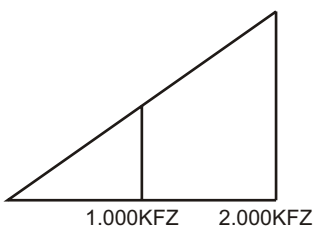
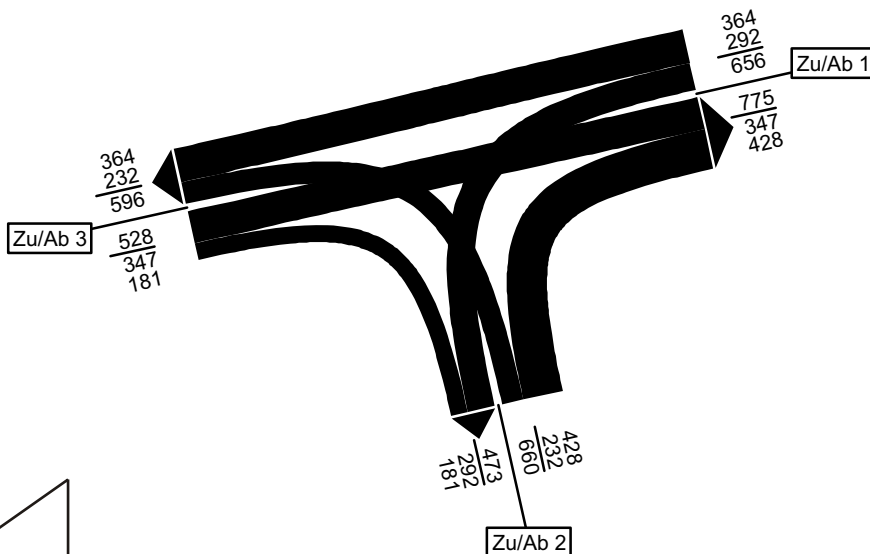



# Stadt Dachau

Zählstelle: K48 Freisinger Straße / Konrad-Adenauer-Straße

Zusammenfassung Stundengruppen

Zähltag: Do., 21.06.2007

Zu-/Ablauf 1: Etzenhausener Str.  
 Zu-/Ablauf 2: Freisinger Str. (von/nach Stadtauswärts)  
 Zu-/Ablauf 3: Konrad-Adenauer-Str.  
 Zu-/Ablauf 4: Mittermayerstr.

Spezifische Spitzenstunde morgens  
 07:15 Uhr - 08:15 Uhr in KFZ

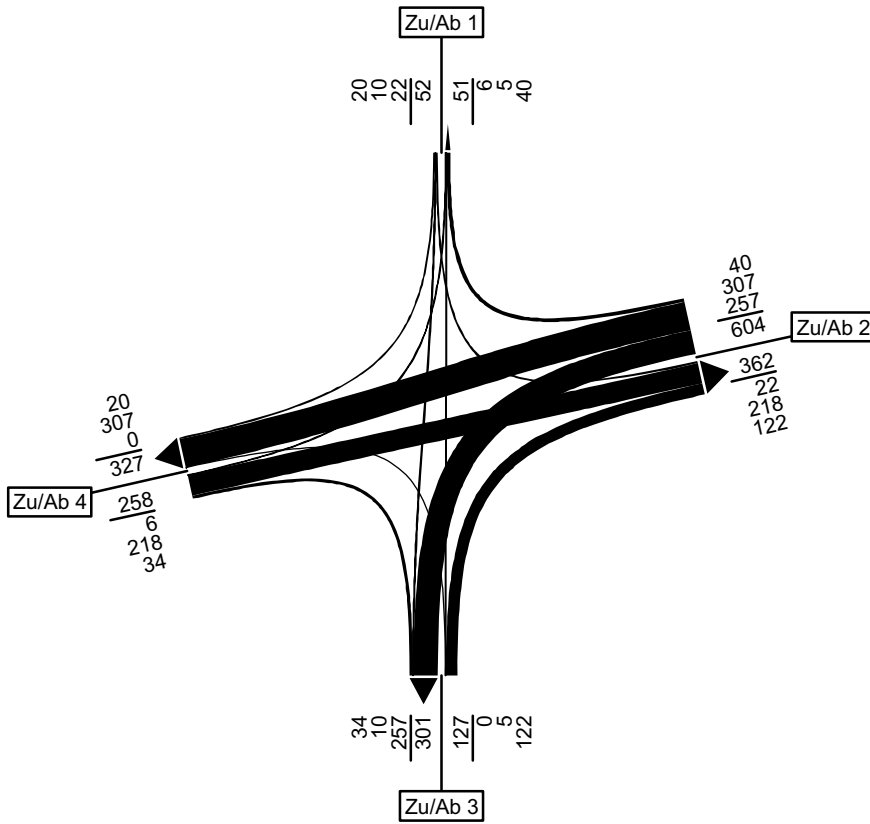

Spezifische Spitzenstunde abends  
 17:00 Uhr - 18:00 Uhr in KFZ

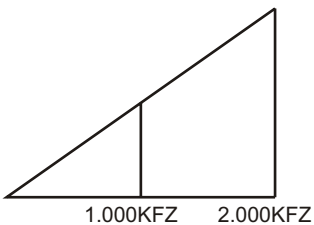
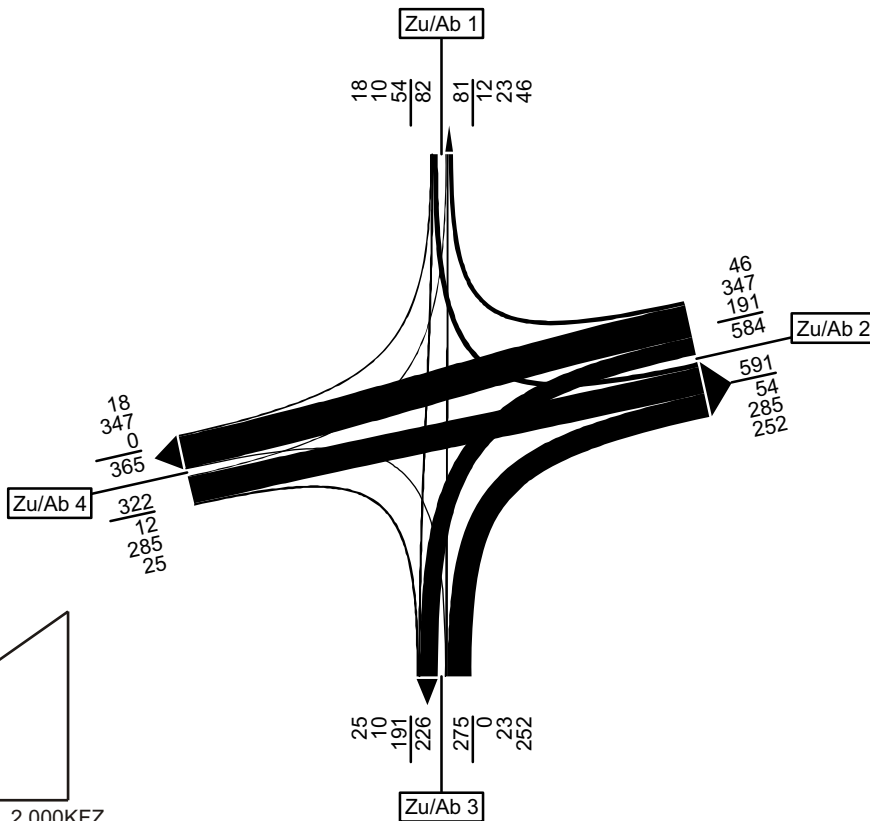



**GROSSE KREISSTADT DACHAU**

**Verkehrserhebungen 2007**

Querschnittsbelastungen in KFZ/24h  
(vorläufige Hochrechnung auf Basis  
nicht gesicherter Faktoren)

Verkehrserhebungen durchgeführt im II. Quartal 2007

Stand: Juli 2007



Richard-Strauss-Str. 32  
8 2 1 5 2 P l a n e g g      I N G E V O S T  
Dipl.-Ing. Chr. Fahnberg