



**GROSSE KREISSTADT  
DACHAU**

**Verkehrserhebungen**

**2007/2008**

- Ergebnisse -  
Ergänzungen 2008



Stand: Mai 2008

Richard-Strauss-Str. 32  
82152 Planegg

**I N G E V O S T**  
Dipl.-Ing. Christian Fahnberg

Stadt Dachau

Verkehrszählungen 2007 / 2008

Zählzeit: 06:00 Uhr - 10:00 Uhr und 15:00 Uhr - 19:00 Uhr

Knotenpunkt	Zähltag					
	Do. 26.10.06	Di. 19.04.07	Di. 24.04.07	Do. 26.04.07	Do. 21.06.07	Do. 08.05.08
K1 Augsburg Straße / Weblinger Weg		X				
K2 Freisinger Straße / Weblinger Weg		X				
K3 Augsburg Straße / Dr.-Hiller-Straße		X				
K4 Augsburg Straße / Mittermayerstraße		X				
K5 Ludwig-Thoma-Straße / Mittermayerstraße		X				
K6 Brucker Straße / Abzweig Einsbach		X				
K8 Ludwig-Thoma-Straße / Ostenstraße		X				
K9 Ludwig-Thoma-Straße / Martin-Huber-Straße		X				
K10 Ludwig-Thoma-Straße / Karlsberg			X			
K11 Augsburg Straße / Karlsberg			X			
K12 Gröbenrieder Straße / Himmelreichweg			X			
K13 Gröbenrieder Straße / Eduard-Ziegler-Straße			X			
K14 Gröbenrieder Straße / Emmeringer Straße			X			
K15 Langwieder Straße / Emmeringer Straße			X			
K16 Münchener Straße / Anton-Hechtl-Straße			X			
K17 Münchener Straße / Goethestraße			X			
K18 Münchener Straße / Bahnhofstraße			X			
K19 Münchener Straße / Gröbenrieder Straße			X			
K20 Münchener Straße / Schleißheimer Straße			X			
K21 Schleißheimer Straße / Frühlingstraße				X		
K22 Schleißheimer Straße / Pollnstraße				X		
K23 Schleißheimer Straße / Würmstraße	X					
K24 Schleißheimer Straße / Kopernikusstraße	X					
K25 Alte Römerstraße / Sudetenlandstraße				X		
K26 Alte Römerstraße / Rudolf-Diesel-Straße				X		
K27 Alte Römerstraße / Pater-Roth-Straße				X		
K28 ST2339 / Alte Römerstraße				X		X
K29 Augustenfelder Straße / Obere Mooschwaigstraße				X		
K30 Sudetenlandstraße / Theodor-Heuss-Straße				X		
K31 Theodor-Heuss-Straße / Wallbergstraße				X		
K32 Wallberstraße / Augustenfelder Straße				X		
K33 Münchener Straße / Wallbergstraße				X		
K41 Freisinger Straße / Erich-Ollenhauer-Straße					X	
K42 Augsburg Straße / Bürgermeister-Zauner-Ring					X	
K43 Theodor-Heuss-Straße / Schleißheimer Straße	X					
K44 Schleißheimer Straße / Alte-Römer-Straße	X					
K45 Ludwig-Thoma-Straße / Konrad-Adenauer-Straße					X	
K46 Erich-Ollenhauer-Straße / Friedenstraße					X	
K47 Brucker Straße / Ludwig-Dill-Straße					X	
K48 Freisinger Straße / Konrad-Adenauer-Straße					X	
K51 ST2330 / Prittlbacher Straße						X
K52 Alte Römerstraße / Hans-Böckler-Straße						X
K53 Fraunhoferstraße / Kopernikusstraße						X
K54 Sudetenlandstraße / Würmstraße						X
K55 Erich-Ollenhauer-Straße / Ostenstraße						X
K56 Schleißheimer Straße / Friedenstraße						X
K57 Schillerstraße / Gröbenrieder Straße						X
K58 Schillerstraße / Uhdestraße						X

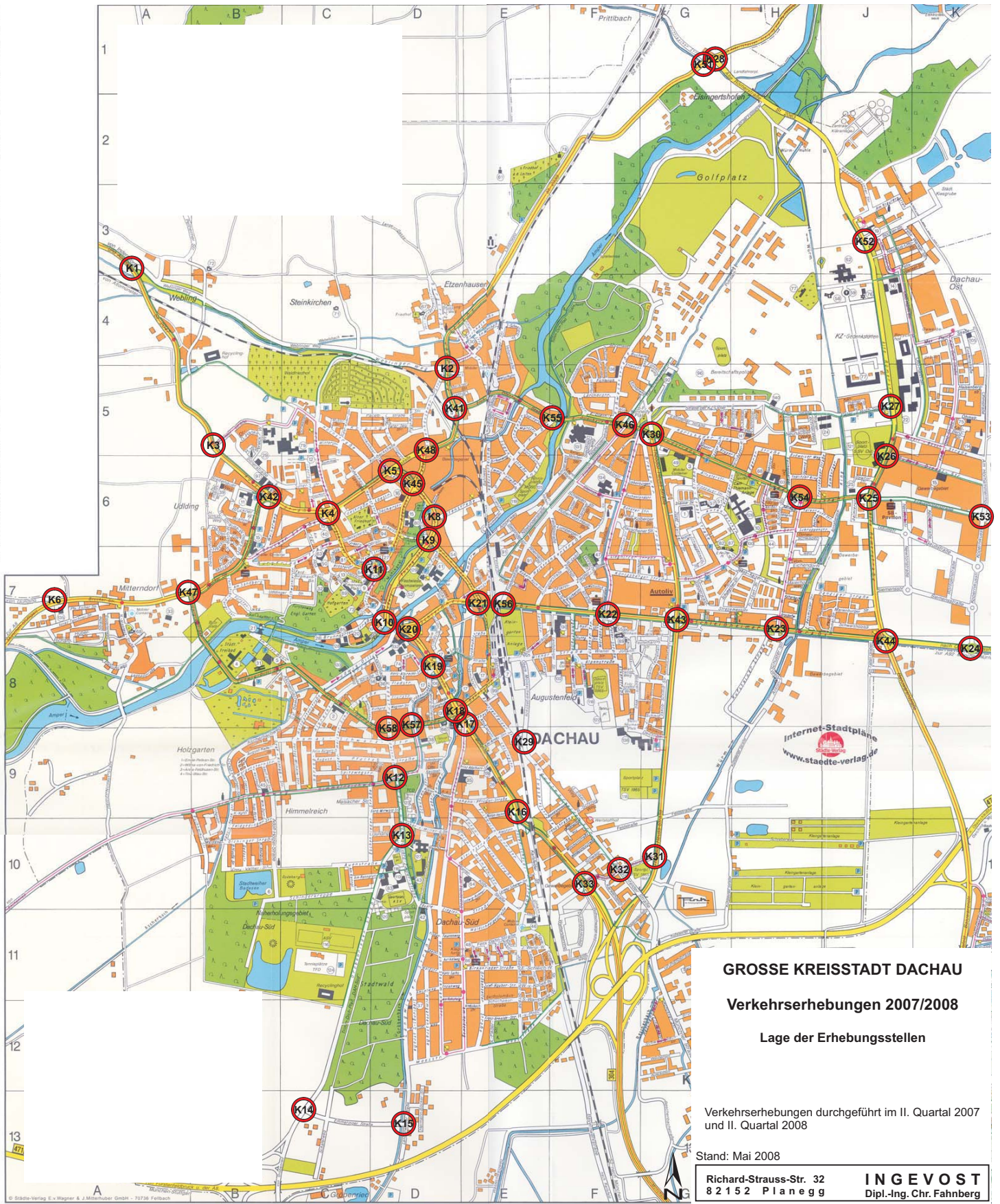

**GROSSE KREISSTADT DACHAU**

**Verkehrserhebungen 2007/2008**

**Lage der Erhebungsstellen**

Verkehrserhebungen durchgeführt im II. Quartal 2007 und II. Quartal 2008

Stand: Mai 2008

Richard-Strauss-Str. 32  
8 2 1 5 2 P l a n e g g

**INGEVOST**  
Dipl.-Ing. Chr. Fahnberg

**Stadt Dachau**

Zählstelle: K28 ST2339 / Alte Römerstraße

Zu-/Ablauf 1: ST2339 (von/nach Freising)

Zu-/Ablauf 2: Alte Römerstr.

Zu-/Ablauf 3: ST2339 (von/nach Etzenhausen)

Zusammenfassung Stundengruppen

Zähltag: Do., 08.05.2008

Zählzeit: 06:00 Uhr - 10:00 Uhr und 15:00 Uhr - 19:00 Uhr

**Summe Zähizeit (06:00 Uhr - 10:00 Uhr und 15:00 Uhr - 19:00 Uhr)**

FZ-ART	1-2	1-3	1-4	2-1	2-3	2-4	3-1	3-2	3-4	4-1	4-2	4-3	Zu. 1	Zu. 2	Zu. 3	Zu. 4	Ab. 1	Ab. 2	Ab. 3	Ab. 4	K-Sum
RAD	13	45	0	19	22	0	28	31	0	0	0	0	58	41	59	0	47	44	67	0	158
KRAD	108	76	0	119	62	0	38	63	0	0	0	0	184	181	101	0	157	171	138	0	466
PKW	3135	1972	0	2837	1003	0	1341	1543	0	0	0	0	5107	3840	2884	0	4178	4678	2975	0	11831
BUS	12	6	0	6	3	0	4	3	0	0	0	0	18	9	7	0	10	15	9	0	34
LFW	186	110	0	140	58	0	72	125	0	0	0	0	296	198	197	0	212	311	168	0	691
LKW	74	52	0	78	19	0	47	39	0	0	0	0	126	97	86	0	125	113	71	0	309
LZ	45	40	0	51	13	0	26	24	0	0	0	0	85	64	50	0	77	69	53	0	199
<b>KFZ</b>	<b>3560</b>	<b>2256</b>	<b>0</b>	<b>3231</b>	<b>1158</b>	<b>0</b>	<b>1528</b>	<b>1797</b>	<b>0</b>	<b>0</b>	<b>0</b>	<b>0</b>	<b>5816</b>	<b>4389</b>	<b>3325</b>	<b>0</b>	<b>4759</b>	<b>5357</b>	<b>3414</b>	<b>0</b>	<b>13530</b>
SV	131	98	0	135	35	0	77	66	0	0	0	0	229	170	143	0	212	197	133	0	542
PV	3255	2054	0	2962	1068	0	1383	1609	0	0	0	0	5309	4030	2992	0	4345	4864	3122	0	12331
GV	305	202	0	269	90	0	145	188	0	0	0	0	507	359	333	0	414	493	292	0	1199
<b>FZ-ART</b>	<b>1-2</b>	<b>1-3</b>	<b>1-4</b>	<b>2-1</b>	<b>2-3</b>	<b>2-4</b>	<b>3-1</b>	<b>3-2</b>	<b>3-4</b>	<b>4-1</b>	<b>4-2</b>	<b>4-3</b>	<b>Zu. 1</b>	<b>Zu. 2</b>	<b>Zu. 3</b>	<b>Zu. 4</b>	<b>Ab. 1</b>	<b>Ab. 2</b>	<b>Ab. 3</b>	<b>Ab. 4</b>	<b>K-Sum</b>

**Summe Zählintervall 06:00 Uhr - 10:00 Uhr**

FZ-ART	1-2	1-3	1-4	2-1	2-3	2-4	3-1	3-2	3-4	4-1	4-2	4-3	Zu. 1	Zu. 2	Zu. 3	Zu. 4	Ab. 1	Ab. 2	Ab. 3	Ab. 4	K-Sum
RAD	2	39	0	4	3	0	19	24	0	0	0	0	41	7	43	0	23	26	42	0	91
KRAD	59	18	0	15	3	0	7	43	0	0	0	0	77	18	50	0	22	102	21	0	145
PKW	1907	910	0	695	182	0	481	1147	0	0	0	0	2817	877	1628	0	1176	3054	1092	0	5322
BUS	7	6	0	5	2	0	2	2	0	0	0	0	13	7	4	0	7	9	8	0	24
LFW	126	59	0	44	23	0	30	84	0	0	0	0	185	67	114	0	74	210	82	0	366
LKW	42	27	0	31	7	0	21	25	0	0	0	0	69	38	46	0	52	67	34	0	153
LZ	23	22	0	21	8	0	8	14	0	0	0	0	45	29	22	0	29	37	30	0	96
<b>KFZ</b>	<b>2164</b>	<b>1042</b>	<b>0</b>	<b>811</b>	<b>225</b>	<b>0</b>	<b>549</b>	<b>1315</b>	<b>0</b>	<b>0</b>	<b>0</b>	<b>0</b>	<b>3206</b>	<b>1036</b>	<b>1864</b>	<b>0</b>	<b>1360</b>	<b>3479</b>	<b>1267</b>	<b>0</b>	<b>6106</b>
SV	72	55	0	57	17	0	31	41	0	0	0	0	127	74	72	0	88	113	72	0	273
PV	1973	934	0	715	187	0	490	1192	0	0	0	0	2907	902	1682	0	1205	3165	1121	0	5491
GV	191	108	0	96	38	0	59	123	0	0	0	0	299	134	182	0	155	314	146	0	615
<b>FZ-ART</b>	<b>1-2</b>	<b>1-3</b>	<b>1-4</b>	<b>2-1</b>	<b>2-3</b>	<b>2-4</b>	<b>3-1</b>	<b>3-2</b>	<b>3-4</b>	<b>4-1</b>	<b>4-2</b>	<b>4-3</b>	<b>Zu. 1</b>	<b>Zu. 2</b>	<b>Zu. 3</b>	<b>Zu. 4</b>	<b>Ab. 1</b>	<b>Ab. 2</b>	<b>Ab. 3</b>	<b>Ab. 4</b>	<b>K-Sum</b>

**Summe Zählintervall 15:00 Uhr - 19:00 Uhr**

FZ-ART	1-2	1-3	1-4	2-1	2-3	2-4	3-1	3-2	3-4	4-1	4-2	4-3	Zu. 1	Zu. 2	Zu. 3	Zu. 4	Ab. 1	Ab. 2	Ab. 3	Ab. 4	K-Sum
RAD	11	6	0	15	19	0	9	7	0	0	0	0	17	34	16	0	24	18	25	0	67
KRAD	49	58	0	104	59	0	31	20	0	0	0	0	107	163	51	0	135	69	117	0	321
PKW	1228	1062	0	2142	821	0	860	396	0	0	0	0	2290	2963	1256	0	3002	1624	1883	0	6509
BUS	5	0	0	1	1	0	2	1	0	0	0	0	5	2	3	0	3	6	1	0	10
LFW	60	51	0	96	35	0	42	41	0	0	0	0	111	131	83	0	138	101	86	0	325
LKW	32	25	0	47	12	0	26	14	0	0	0	0	57	59	40	0	73	46	37	0	156
LZ	22	18	0	30	5	0	18	10	0	0	0	0	40	35	28	0	48	32	23	0	103
<b>KFZ</b>	<b>1396</b>	<b>1214</b>	<b>0</b>	<b>2420</b>	<b>933</b>	<b>0</b>	<b>979</b>	<b>482</b>	<b>0</b>	<b>0</b>	<b>0</b>	<b>0</b>	<b>2610</b>	<b>3353</b>	<b>1461</b>	<b>0</b>	<b>3399</b>	<b>1878</b>	<b>2147</b>	<b>0</b>	<b>7424</b>
SV	59	43	0	78	18	0	46	25	0	0	0	0	102	96	71	0	124	84	61	0	269
PV	1282	1120	0	2247	881	0	893	417	0	0	0	0	2402	3128	1310	0	3140	1699	2001	0	6840
GV	114	94	0	173	52	0	86	65	0	0	0	0	208	225	151	0	259	179	146	0	584
<b>FZ-ART</b>	<b>1-2</b>	<b>1-3</b>	<b>1-4</b>	<b>2-1</b>	<b>2-3</b>	<b>2-4</b>	<b>3-1</b>	<b>3-2</b>	<b>3-4</b>	<b>4-1</b>	<b>4-2</b>	<b>4-3</b>	<b>Zu. 1</b>	<b>Zu. 2</b>	<b>Zu. 3</b>	<b>Zu. 4</b>	<b>Ab. 1</b>	<b>Ab. 2</b>	<b>Ab. 3</b>	<b>Ab. 4</b>	<b>K-Sum</b>

**spezifische Spitzenstunde morgens 07:15 Uhr - 08:15 Uhr**

FZ-ART	1-2	1-3	1-4	2-1	2-3	2-4	3-1	3-2	3-4	4-1	4-2	4-3	Zu. 1	Zu. 2	Zu. 3	Zu. 4	Ab. 1	Ab. 2	Ab. 3	Ab. 4	K-Sum
RAD	0	23	0	1	0	0	15	7	0	0	0	0	23	1	22	0	16	7	23	0	46
KRAD	15	5	0	1	0	0	2	12	0	0	0	0	20	1	14	0	3	27	5	0	35
PKW	603	333	0	177	31	0	142	434	0	0	0	0	936	208	576	0	319	1037	364	0	1720
BUS	2	3	0	3	0	0	2	0	0	0	0	0	5	3	2	0	5	2	3	0	10
LFW	38	17	0	7	4	0	6	27	0	0	0	0	55	11	33	0	13	65	21	0	99
LKW	3	11	0	12	2	0	4	6	0	0	0	0	14	14	10	0	16	9	13	0	38
LZ	5	6	0	8	2	0	0	2	0	0	0	0	11	10	2	0	8	7	8	0	23
<b>KFZ</b>	<b>666</b>	<b>375</b>	<b>0</b>	<b>208</b>	<b>39</b>	<b>0</b>	<b>156</b>	<b>481</b>	<b>0</b>	<b>0</b>	<b>0</b>	<b>0</b>	<b>1041</b>	<b>247</b>	<b>637</b>	<b>0</b>	<b>364</b>	<b>1147</b>	<b>414</b>	<b>0</b>	<b>1925</b>
SV	10	20	0	23	4	0	6	8	0	0	0	0	30	27	14	0	29	18	24	0	71
PV	620	341	0	181	31	0	146	446	0	0	0	0	961	212	592	0	327	1066	372	0	1765
GV	46	34	0	27	8	0	10	35	0	0	0	0	80	35	45	0	37	81	42	0	160
<b>FZ-ART</b>	<b>1-2</b>	<b>1-3</b>	<b>1-4</b>	<b>2-1</b>	<b>2-3</b>	<b>2-4</b>	<b>3-1</b>	<b>3-2</b>	<b>3-4</b>	<b>4-1</b>	<b>4-2</b>	<b>4-3</b>	<b>Zu. 1</b>	<b>Zu. 2</b>	<b>Zu. 3</b>	<b>Zu. 4</b>	<b>Ab. 1</b>	<b>Ab. 2</b>	<b>Ab. 3</b>	<b>Ab. 4</b>	<b>K-Sum</b>

**spezifische Spitzenstunde abends 17:00 Uhr - 18:00 Uhr**

FZ-ART	1-2	1-3	1-4	2-1	2-3	2-4	3-1	3-2	3-4	4-1	4-2	4-3	Zu. 1	Zu. 2	Zu. 3	Zu. 4	Ab. 1	Ab. 2	Ab. 3	Ab. 4	K-Sum
RAD	1	0	0	3	7	0	3	0	0	0	0	0	1	10	3	0	6	1	7	0	14
KRAD	18	9	0	30	11	0	12	2	0	0	0	0	27	41	14	0	42	20	20	0	82
PKW	339	342	0	645	208	0	245	97	0	0	0	0	681	853	342	0	890	436	550	0	1876
BUS	1	0	0	0	0	0	0	1	0	0	0	0	1	0	1	0	0	2	0	0	2
LFW	11	23	0	34	9	0	10	8	0	0	0	0	34	43	18	0	44	19	32	0	

# Stadt Dachau

Zählstelle: K28 ST2339 / Alte Römerstraße

Zusammenfassung Stundengruppen

Zähltag: Do., 08.05.2008

Zählzeit: 06:00 Uhr - 10:00 Uhr und 15:00 Uhr - 19:00 Uhr

Zu-/Ablauf 1: ST2339 (von/nach Freising)

Zu-/Ablauf 2: Alte Römerstr.

Zu-/Ablauf 3: St2339 (von/nach Etzenhausen)

Spezifische Spitzenstunde morgens  
07:15 Uhr - 08:15 Uhr in KFZ

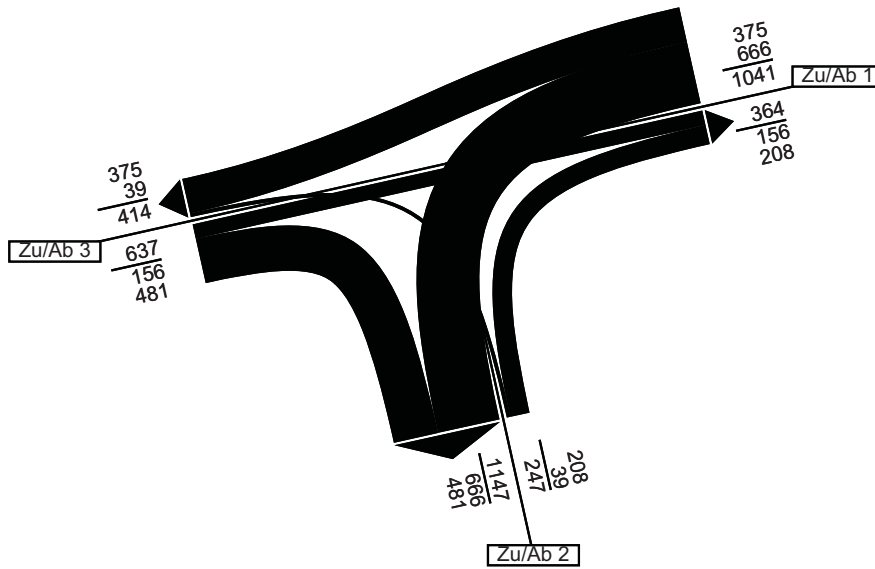

Spezifische Spitzenstunde abends  
17:00 Uhr - 18:00 Uhr in KFZ

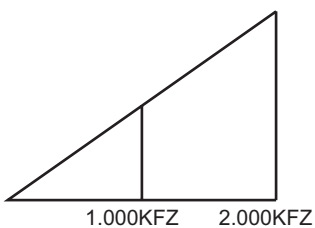
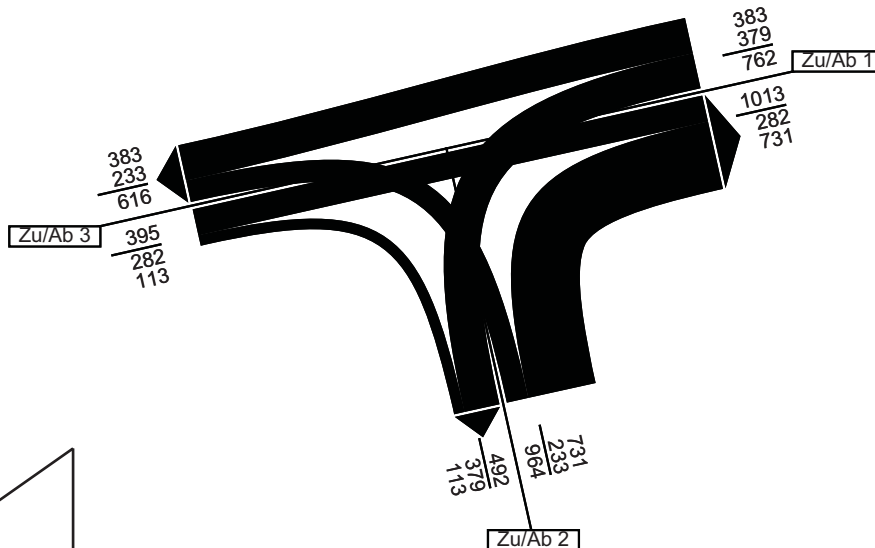

**Stadt Dachau**

Zählstelle: K51 ST2339 / Prittbacher Straße

Zu-/Ablauf 1: ST2339 (von/nach Freising)

Zu-/Ablauf 2: ST2339 (von/nach Etzenhausen)

Zu-/Ablauf 3: Prittbacher Straße

Zusammenfassung Stundengruppen

Zähltag: Do., 08.05.2008

Zählzeit: 06:00 Uhr - 10:00 Uhr und 15:00 Uhr - 19:00 Uhr

**Summe Zählzeit (06:00 Uhr - 10:00 Uhr und 15:00 Uhr - 19:00 Uhr)**

FZ-ART	1-2	1-3	1-4	2-1	2-3	2-4	3-1	3-2	3-4	4-1	4-2	4-3	Zu. 1	Zu. 2	Zu. 3	Zu. 4	Ab. 1	Ab. 2	Ab. 3	Ab. 4	K-Sum
RAD	63	4	0	44	37	0	15	104	0	0	0	0	67	81	119	0	59	167	41	0	267
KRAD	88	50	0	57	15	0	44	19	0	0	0	0	138	72	63	0	101	107	65	0	273
PKW	2215	760	0	1790	208	0	1094	304	0	0	0	0	2975	1998	1398	0	2884	2519	968	0	6371
BUS	7	2	0	6	3	0	1	0	0	0	0	0	9	9	1	0	7	7	5	0	19
LFW	127	41	0	149	6	0	48	12	0	0	0	0	168	155	60	0	197	139	47	0	383
LKW	62	9	0	79	2	0	7	4	0	0	0	0	71	81	11	0	86	66	11	0	163
LZ	46	7	0	43	1	0	7	2	0	0	0	0	53	44	9	0	50	48	8	0	106
<b>KFZ</b>	<b>2545</b>	<b>869</b>	<b>0</b>	<b>2124</b>	<b>235</b>	<b>0</b>	<b>1201</b>	<b>341</b>	<b>0</b>	<b>0</b>	<b>0</b>	<b>0</b>	<b>3414</b>	<b>2359</b>	<b>1542</b>	<b>0</b>	<b>3325</b>	<b>2886</b>	<b>1104</b>	<b>0</b>	<b>7315</b>
SV	115	18	0	128	6	0	15	6	0	0	0	0	133	134	21	0	143	121	24	0	288
PV	2310	812	0	1853	226	0	1139	323	0	0	0	0	3122	2079	1462	0	2992	2633	1038	0	6663
GV	235	57	0	271	9	0	62	18	0	0	0	0	292	280	80	0	333	253	66	0	652
<b>FZ-ART</b>	<b>1-2</b>	<b>1-3</b>	<b>1-4</b>	<b>2-1</b>	<b>2-3</b>	<b>2-4</b>	<b>3-1</b>	<b>3-2</b>	<b>3-4</b>	<b>4-1</b>	<b>4-2</b>	<b>4-3</b>	<b>Zu. 1</b>	<b>Zu. 2</b>	<b>Zu. 3</b>	<b>Zu. 4</b>	<b>Ab. 1</b>	<b>Ab. 2</b>	<b>Ab. 3</b>	<b>Ab. 4</b>	<b>K-Sum</b>

**Summe Zählintervall 06:00 Uhr - 10:00 Uhr**

FZ-ART	1-2	1-3	1-4	2-1	2-3	2-4	3-1	3-2	3-4	4-1	4-2	4-3	Zu. 1	Zu. 2	Zu. 3	Zu. 4	Ab. 1	Ab. 2	Ab. 3	Ab. 4	K-Sum
RAD	41	1	0	31	12	0	12	59	0	0	0	0	42	43	71	0	43	100	13	0	156
KRAD	18	3	0	17	1	0	33	12	0	0	0	0	21	18	45	0	50	30	4	0	84
PKW	958	134	0	833	38	0	795	200	0	0	0	0	1092	871	995	0	1628	1158	172	0	2958
BUS	6	2	0	3	1	0	1	0	0	0	0	0	8	4	1	0	4	6	3	0	13
LFW	70	12	0	77	3	0	37	7	0	0	0	0	82	80	44	0	114	77	15	0	206
LKW	29	5	0	43	0	0	3	3	0	0	0	0	34	43	6	0	46	32	5	0	83
LZ	27	3	0	18	1	0	4	1	0	0	0	0	30	19	5	0	22	28	4	0	54
<b>KFZ</b>	<b>1108</b>	<b>159</b>	<b>0</b>	<b>991</b>	<b>44</b>	<b>0</b>	<b>873</b>	<b>223</b>	<b>0</b>	<b>0</b>	<b>0</b>	<b>0</b>	<b>1267</b>	<b>1035</b>	<b>1096</b>	<b>0</b>	<b>1864</b>	<b>1331</b>	<b>203</b>	<b>0</b>	<b>3398</b>
SV	62	10	0	64	2	0	8	4	0	0	0	0	72	66	12	0	72	66	12	0	150
PV	982	139	0	853	40	0	829	212	0	0	0	0	1121	893	1041	0	1682	1194	179	0	3055
GV	126	20	0	138	4	0	44	11	0	0	0	0	146	142	55	0	182	137	24	0	343
<b>FZ-ART</b>	<b>1-2</b>	<b>1-3</b>	<b>1-4</b>	<b>2-1</b>	<b>2-3</b>	<b>2-4</b>	<b>3-1</b>	<b>3-2</b>	<b>3-4</b>	<b>4-1</b>	<b>4-2</b>	<b>4-3</b>	<b>Zu. 1</b>	<b>Zu. 2</b>	<b>Zu. 3</b>	<b>Zu. 4</b>	<b>Ab. 1</b>	<b>Ab. 2</b>	<b>Ab. 3</b>	<b>Ab. 4</b>	<b>K-Sum</b>

**Summe Zählintervall 15:00 Uhr - 19:00 Uhr**

FZ-ART	1-2	1-3	1-4	2-1	2-3	2-4	3-1	3-2	3-4	4-1	4-2	4-3	Zu. 1	Zu. 2	Zu. 3	Zu. 4	Ab. 1	Ab. 2	Ab. 3	Ab. 4	K-Sum
RAD	22	3	0	13	25	0	3	45	0	0	0	0	25	38	48	0	16	67	28	0	111
KRAD	70	47	0	40	14	0	11	7	0	0	0	0	117	54	18	0	51	77	61	0	189
PKW	1257	626	0	957	170	0	299	104	0	0	0	0	1883	1127	403	0	1256	1361	796	0	3413
BUS	1	0	0	3	2	0	0	0	0	0	0	0	1	5	0	0	3	1	2	0	6
LFW	57	29	0	72	3	0	11	5	0	0	0	0	86	75	16	0	83	62	32	0	177
LKW	33	4	0	36	2	0	4	1	0	0	0	0	37	38	5	0	40	34	6	0	80
LZ	19	4	0	25	0	0	3	1	0	0	0	0	23	25	4	0	28	20	4	0	52
<b>KFZ</b>	<b>1437</b>	<b>710</b>	<b>0</b>	<b>1133</b>	<b>191</b>	<b>0</b>	<b>328</b>	<b>118</b>	<b>0</b>	<b>0</b>	<b>0</b>	<b>0</b>	<b>2147</b>	<b>1324</b>	<b>446</b>	<b>0</b>	<b>1461</b>	<b>1555</b>	<b>901</b>	<b>0</b>	<b>3917</b>
SV	53	8	0	64	4	0	7	2	0	0	0	0	61	68	9	0	71	55	12	0	138
PV	1328	673	0	1000	186	0	310	111	0	0	0	0	2001	1186	421	0	1310	1439	859	0	3608
GV	109	37	0	133	5	0	18	7	0	0	0	0	146	138	25	0	151	116	42	0	309
<b>FZ-ART</b>	<b>1-2</b>	<b>1-3</b>	<b>1-4</b>	<b>2-1</b>	<b>2-3</b>	<b>2-4</b>	<b>3-1</b>	<b>3-2</b>	<b>3-4</b>	<b>4-1</b>	<b>4-2</b>	<b>4-3</b>	<b>Zu. 1</b>	<b>Zu. 2</b>	<b>Zu. 3</b>	<b>Zu. 4</b>	<b>Ab. 1</b>	<b>Ab. 2</b>	<b>Ab. 3</b>	<b>Ab. 4</b>	<b>K-Sum</b>

**spezifische Spitzenstunde morgens 07:15 Uhr - 08:15 Uhr**

FZ-ART	1-2	1-3	1-4	2-1	2-3	2-4	3-1	3-2	3-4	4-1	4-2	4-3	Zu. 1	Zu. 2	Zu. 3	Zu. 4	Ab. 1	Ab. 2	Ab. 3	Ab. 4	K-Sum
RAD	22	1	0	20	3	0	2	38	0	0	0	0	23	23	40	0	22	60	4	0	86
KRAD	5	0	0	3	0	0	11	3	0	0	0	0	5	3	14	0	14	8	0	0	22
PKW	341	23	0	299	9	0	277	74	0	0	0	0	364	308	351	0	576	415	32	0	1023
BUS	3	0	0	2	0	0	0	0	0	0	0	0	3	2	0	0	2	3	0	0	5
LFW	18	3	0	26	0	0	7	2	0	0	0	0	21	26	9	0	33	20	3	0	56
LKW	11	2	0	8	0	0	2	3	0	0	0	0	13	8	5	0	10	14	2	0	26
LZ	7	1	0	2	1	0	0	0	0	0	0	0	8	3	0	0	2	7	2	0	11
<b>KFZ</b>	<b>385</b>	<b>29</b>	<b>0</b>	<b>340</b>	<b>10</b>	<b>0</b>	<b>297</b>	<b>82</b>	<b>0</b>	<b>0</b>	<b>0</b>	<b>0</b>	<b>414</b>	<b>350</b>	<b>379</b>	<b>0</b>	<b>637</b>	<b>467</b>	<b>39</b>	<b>0</b>	<b>1143</b>
SV	21	3	0	12	1	0	2	3	0	0	0	0	24	13	5	0	14	24	4	0	42
PV	349	23	0	304	9	0	288	77	0	0	0	0	372	313	365	0	592	426	32	0	1050
GV	36	6	0	36	1	0	9	5	0	0	0	0	42	37	14	0	45	41	7	0	93
<b>FZ-ART</b>	<b>1-2</b>	<b>1-3</b>	<b>1-4</b>	<b>2-1</b>	<b>2-3</b>	<b>2-4</b>	<b>3-1</b>	<b>3-2</b>	<b>3-4</b>	<b>4-1</b>	<b>4-2</b>	<b>4-3</b>	<b>Zu. 1</b>	<b>Zu. 2</b>	<b>Zu. 3</b>	<b>Zu. 4</b>	<b>Ab. 1</b>	<b>Ab. 2</b>	<b>Ab. 3</b>	<b>Ab. 4</b>	<b>K-Sum</b>

**spezifische Spitzenstunde abends 17:45 Uhr - 18:45 Uhr**

FZ-ART	1-2	1-3	1-4	2-1	2-3	2-4	3-1	3-2	3-4	4-1	4-2	4-3	Zu. 1	Zu. 2	Zu. 3	Zu. 4	Ab. 1	Ab. 2	Ab. 3	Ab. 4	K-Sum
RAD	4	3	0	3	7	0	2	16	0	0	0	0	7	10	18	0	5	20	10	0	35
KRAD	22	17	0	7	8	0	1	1	0	0	0	0	39	15	2	0	8	23	25	0	56
PKW	406	160	0	308	66	0	86	19	0	0	0	0	566	374	105	0	394	425	226	0	1045
BUS	0	0	0	1	1	0	0	0	0	0	0	0	0	2	0	0	1	0	1	0	2
LFW	15	5	0	9	1	0	1	1	0	0	0	0	20	10	2	0	10	16	6	0	32
LKW	6	0	0	5	1	0	0	0	0	0	0	0	6	6	0	0	5	6	1	0	12
LZ	8	0	0	4	0	0	0	0</													

# Stadt Dachau

Zählstelle: K51 ST2339 / Prittbacher Straße

Zusammenfassung Stundengruppen

Zähltag: Do., 08.05.2008

Zählzeit: 06:00 Uhr - 10:00 Uhr und 15:00 Uhr - 19:00 Uhr

Zu-/Ablauf 1: ST2339 (von/nach Freising)

Zu-/Ablauf 2: ST2339 (von/nach Etzenhausen)

Zu-/Ablauf 3: Prittbacher Straße

Spezifische Spitzenstunde morgens  
07:15 Uhr - 08:15 Uhr in KFZ

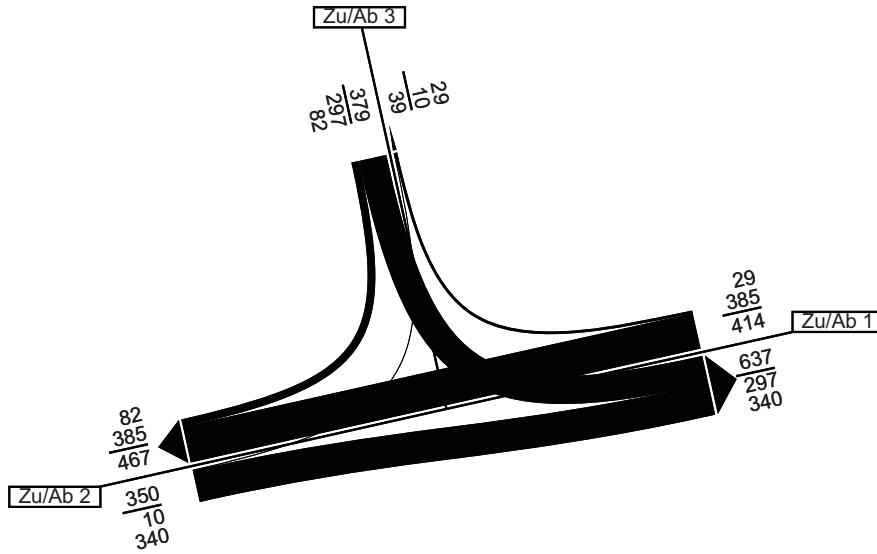

Spezifische Spitzenstunde abends  
17:45 Uhr - 18:45 Uhr in KFZ

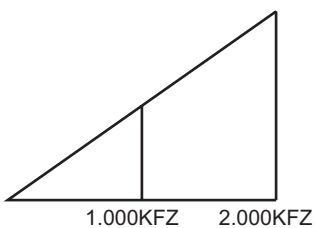
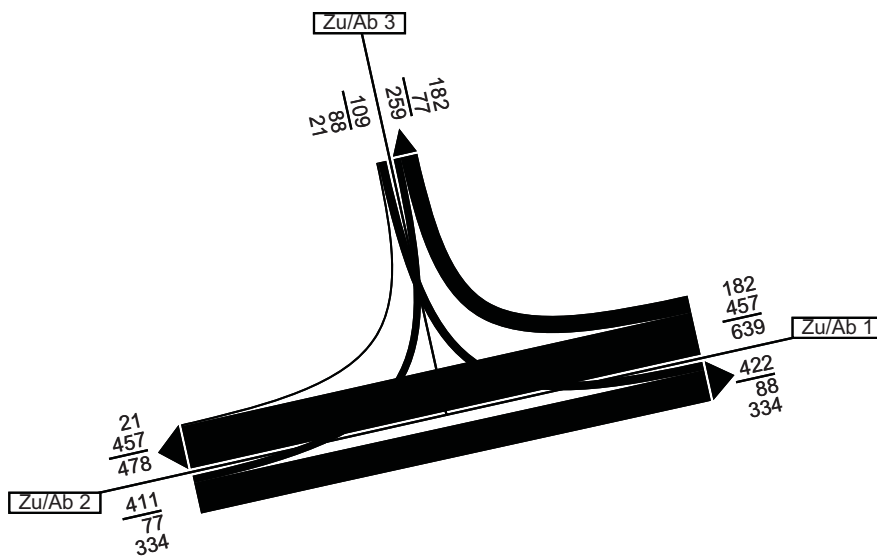

**Stadt Dachau**

Zählstelle: K52 ST2063 Alte Römerstraße / Hans-Böckler-Straße

Zu-/Ablauf 1: Hans-Böckler-Str.  
 Zu-/Ablauf 2: Alte Römerstraße (von/nach Stadteinwärts)  
 Zu-/Ablauf 3: Alte Römerstraße (von/nach Stadtauswärts)

Zusammenfassung Stundengruppen

Zähltag: Do., 08.05.2008  
 Zählzeit: 06:00 Uhr - 10:00 Uhr und 15:00 Uhr - 19:00 Uhr

**Summe Zählzeit (06:00 Uhr - 10:00 Uhr und 15:00 Uhr - 19:00 Uhr)**

FZ-ART	1-2	1-3	1-4	2-1	2-3	2-4	3-1	3-2	3-4	4-1	4-2	4-3	Zu. 1	Zu. 2	Zu. 3	Zu. 4	Ab. 1	Ab. 2	Ab. 3	Ab. 4	K-Sum
RAD	2	6	0	10	41	0	6	67	0	0	0	0	8	51	73	0	16	69	47	0	132
KRAD	2	32	0	6	148	0	31	144	0	0	0	0	34	154	175	0	37	146	180	0	363
PKW	179	572	0	179	3341	0	700	4087	0	0	0	0	751	3520	4787	0	879	4266	3913	0	9058
BUS	1	2	0	1	8	0	5	11	0	0	0	0	3	9	16	0	6	12	10	0	28
LFW	28	46	0	22	168	0	77	214	0	0	0	0	74	190	291	0	99	242	214	0	555
LKW	11	16	0	12	83	0	26	70	0	0	0	0	27	95	96	0	38	81	99	0	218
LZ	4	8	0	9	47	0	27	75	0	0	0	0	12	56	102	0	36	79	55	0	170
<b>KFZ</b>	<b>225</b>	<b>676</b>	<b>0</b>	<b>229</b>	<b>3795</b>	<b>0</b>	<b>866</b>	<b>4601</b>	<b>0</b>	<b>0</b>	<b>0</b>	<b>0</b>	<b>901</b>	<b>4024</b>	<b>5467</b>	<b>0</b>	<b>1095</b>	<b>4826</b>	<b>4471</b>	<b>0</b>	<b>10392</b>
SV	16	26	0	22	138	0	58	156	0	0	0	0	42	160	214	0	80	172	164	0	416
PV	182	606	0	186	3497	0	736	4242	0	0	0	0	788	3683	4978	0	922	4424	4103	0	9449
GV	43	70	0	43	298	0	130	359	0	0	0	0	113	341	489	0	173	402	368	0	943
<b>FZ-ART</b>	<b>1-2</b>	<b>1-3</b>	<b>1-4</b>	<b>2-1</b>	<b>2-3</b>	<b>2-4</b>	<b>3-1</b>	<b>3-2</b>	<b>3-4</b>	<b>4-1</b>	<b>4-2</b>	<b>4-3</b>	<b>Zu. 1</b>	<b>Zu. 2</b>	<b>Zu. 3</b>	<b>Zu. 4</b>	<b>Ab. 1</b>	<b>Ab. 2</b>	<b>Ab. 3</b>	<b>Ab. 4</b>	<b>K-Sum</b>

**Summe Zählintervall 06:00 Uhr - 10:00 Uhr**

FZ-ART	1-2	1-3	1-4	2-1	2-3	2-4	3-1	3-2	3-4	4-1	4-2	4-3	Zu. 1	Zu. 2	Zu. 3	Zu. 4	Ab. 1	Ab. 2	Ab. 3	Ab. 4	K-Sum
RAD	0	0	0	6	10	0	4	37	0	0	0	0	0	16	41	0	10	37	10	0	57
KRAD	0	0	0	5	18	0	18	88	0	0	0	0	0	23	106	0	23	88	18	0	129
PKW	35	60	0	125	823	0	531	2509	0	0	0	0	95	948	3040	0	656	2544	883	0	4083
BUS	0	2	0	0	4	0	3	5	0	0	0	0	2	4	8	0	3	5	6	0	14
LFW	15	14	0	15	60	0	47	148	0	0	0	0	29	75	195	0	62	163	74	0	299
LKW	6	5	0	6	39	0	14	48	0	0	0	0	11	45	62	0	20	54	44	0	118
LZ	3	3	0	8	19	0	10	38	0	0	0	0	6	27	48	0	18	41	22	0	81
<b>KFZ</b>	<b>59</b>	<b>84</b>	<b>0</b>	<b>159</b>	<b>963</b>	<b>0</b>	<b>623</b>	<b>2836</b>	<b>0</b>	<b>0</b>	<b>0</b>	<b>0</b>	<b>143</b>	<b>1122</b>	<b>3459</b>	<b>0</b>	<b>782</b>	<b>2895</b>	<b>1047</b>	<b>0</b>	<b>4724</b>
SV	9	10	0	14	62	0	27	91	0	0	0	0	19	76	118	0	41	100	72	0	213
PV	35	62	0	130	845	0	552	2602	0	0	0	0	97	975	3154	0	682	2637	907	0	4226
GV	24	22	0	29	118	0	71	234	0	0	0	0	46	147	305	0	100	258	140	0	498
<b>FZ-ART</b>	<b>1-2</b>	<b>1-3</b>	<b>1-4</b>	<b>2-1</b>	<b>2-3</b>	<b>2-4</b>	<b>3-1</b>	<b>3-2</b>	<b>3-4</b>	<b>4-1</b>	<b>4-2</b>	<b>4-3</b>	<b>Zu. 1</b>	<b>Zu. 2</b>	<b>Zu. 3</b>	<b>Zu. 4</b>	<b>Ab. 1</b>	<b>Ab. 2</b>	<b>Ab. 3</b>	<b>Ab. 4</b>	<b>K-Sum</b>

**Summe Zählintervall 15:00 Uhr - 19:00 Uhr**

FZ-ART	1-2	1-3	1-4	2-1	2-3	2-4	3-1	3-2	3-4	4-1	4-2	4-3	Zu. 1	Zu. 2	Zu. 3	Zu. 4	Ab. 1	Ab. 2	Ab. 3	Ab. 4	K-Sum
RAD	2	6	0	4	31	0	2	30	0	0	0	0	8	35	32	0	6	32	37	0	75
KRAD	2	32	0	1	130	0	13	56	0	0	0	0	34	131	69	0	14	58	162	0	234
PKW	144	512	0	54	2518	0	169	1578	0	0	0	0	656	2572	1747	0	223	1722	3030	0	4975
BUS	1	0	0	1	4	0	2	6	0	0	0	0	1	5	8	0	3	7	4	0	14
LFW	13	32	0	7	108	0	30	66	0	0	0	0	45	115	96	0	37	79	140	0	256
LKW	5	11	0	6	44	0	12	22	0	0	0	0	16	50	34	0	18	27	55	0	100
LZ	1	5	0	1	28	0	17	37	0	0	0	0	6	29	54	0	18	38	33	0	89
<b>KFZ</b>	<b>166</b>	<b>592</b>	<b>0</b>	<b>70</b>	<b>2832</b>	<b>0</b>	<b>243</b>	<b>1765</b>	<b>0</b>	<b>0</b>	<b>0</b>	<b>0</b>	<b>758</b>	<b>2902</b>	<b>2008</b>	<b>0</b>	<b>313</b>	<b>1931</b>	<b>3424</b>	<b>0</b>	<b>5668</b>
SV	7	16	0	8	76	0	31	65	0	0	0	0	23	84	96	0	39	72	92	0	203
PV	147	544	0	56	2652	0	184	1640	0	0	0	0	691	2708	1824	0	240	1787	3196	0	5223
GV	19	48	0	14	180	0	59	125	0	0	0	0	67	194	184	0	73	144	228	0	445
<b>FZ-ART</b>	<b>1-2</b>	<b>1-3</b>	<b>1-4</b>	<b>2-1</b>	<b>2-3</b>	<b>2-4</b>	<b>3-1</b>	<b>3-2</b>	<b>3-4</b>	<b>4-1</b>	<b>4-2</b>	<b>4-3</b>	<b>Zu. 1</b>	<b>Zu. 2</b>	<b>Zu. 3</b>	<b>Zu. 4</b>	<b>Ab. 1</b>	<b>Ab. 2</b>	<b>Ab. 3</b>	<b>Ab. 4</b>	<b>K-Sum</b>

**spezifische Spitzenstunde morgens 07:15 Uhr - 08:15 Uhr**

FZ-ART	1-2	1-3	1-4	2-1	2-3	2-4	3-1	3-2	3-4	4-1	4-2	4-3	Zu. 1	Zu. 2	Zu. 3	Zu. 4	Ab. 1	Ab. 2	Ab. 3	Ab. 4	K-Sum
RAD	0	0	0	3	2	0	1	12	0	0	0	0	0	5	13	0	4	12	2	0	18
KRAD	0	0	0	2	1	0	5	29	0	0	0	0	0	3	34	0	7	29	1	0	37
PKW	15	10	0	49	205	0	215	836	0	0	0	0	25	254	1051	0	264	851	215	0	1330
BUS	0	0	0	0	2	0	1	1	0	0	0	0	0	2	2	0	1	1	2	0	4
LFW	3	5	0	6	12	0	13	46	0	0	0	0	8	18	59	0	19	49	17	0	85
LKW	1	3	0	1	16	0	1	9	0	0	0	0	4	17	10	0	2	10	19	0	31
LZ	0	1	0	2	3	0	1	12	0	0	0	0	1	5	13	0	3	12	4	0	19
<b>KFZ</b>	<b>19</b>	<b>19</b>	<b>0</b>	<b>60</b>	<b>239</b>	<b>0</b>	<b>236</b>	<b>933</b>	<b>0</b>	<b>0</b>	<b>0</b>	<b>0</b>	<b>38</b>	<b>299</b>	<b>1169</b>	<b>0</b>	<b>296</b>	<b>952</b>	<b>258</b>	<b>0</b>	<b>1506</b>
SV	1	4	0	3	21	0	3	22	0	0	0	0	5	24	25	0	6	23	25	0	54
PV	15	10	0	51	208	0	221	866	0	0	0	0	25	259	1087	0	272	881	218	0	1371
GV	4	9	0	9	31	0	15	67	0	0	0	0	13	40	82	0	24	71	40	0	135
<b>FZ-ART</b>	<b>1-2</b>	<b>1-3</b>	<b>1-4</b>	<b>2-1</b>	<b>2-3</b>	<b>2-4</b>	<b>3-1</b>	<b>3-2</b>	<b>3-4</b>	<b>4-1</b>	<b>4-2</b>	<b>4-3</b>	<b>Zu. 1</b>	<b>Zu. 2</b>	<b>Zu. 3</b>	<b>Zu. 4</b>	<b>Ab. 1</b>	<b>Ab. 2</b>	<b>Ab. 3</b>	<b>Ab. 4</b>	<b>K-Sum</b>

**spezifische Spitzenstunde abends 16:45 Uhr - 17:45 Uhr**

FZ-ART	1-2	1-3	1-4	2-1	2-3	2-4	3-1	3-2	3-4	4-1	4-2	4-3	Zu. 1	Zu. 2	Zu. 3	Zu. 4	Ab. 1	Ab. 2	Ab. 3	Ab. 4	K-Sum
RAD	1	3	0	1	9	0	2	7	0	0	0	0	4	10	9	0	3	8	12	0	23
KRAD	1	6	0	0	33	0	1	14	0	0	0	0	7	33	15	0	1	15	39	0	55
PKW	41	206	0	13	688	0	51	465	0	0	0	0	247	701	516	0	64	506	894	0	1464
BUS	0	0	0	0	0	0	0	2	0	0	0	0	0	0	2	0	0	2	0	0	2
LFW	2	13	0	1	31	0	8	19	0	0	0	0	15	32	27	0	9	21	44	0	74
LKW	1	3	0	2	15	0	4	5	0	0	0	0	4	17	9	0	6	6	18	0	30
LZ	0	1	0																		



# Stadt Dachau

Zählstelle: K52 ST2063 Alte Römerstraße / Hans-Böckler-Straße

Zusammenfassung Stundengruppen

Zähltag: Do., 08.05.2008

Zählzeit: 06:00 Uhr - 10:00 Uhr und 15:00 Uhr - 19:00 Uhr

Zu-/Ablauf 1: Hans-Böckler-Str.

Zu-/Ablauf 2: Alte Römerstraße (von/nach Stadteinwärts)

Zu-/Ablauf 3: Alte Römerstraße (von/nach Stadtauswärts)

Spezifische Spitzenstunde morgens  
07:15 Uhr - 08:15 Uhr in KFZ

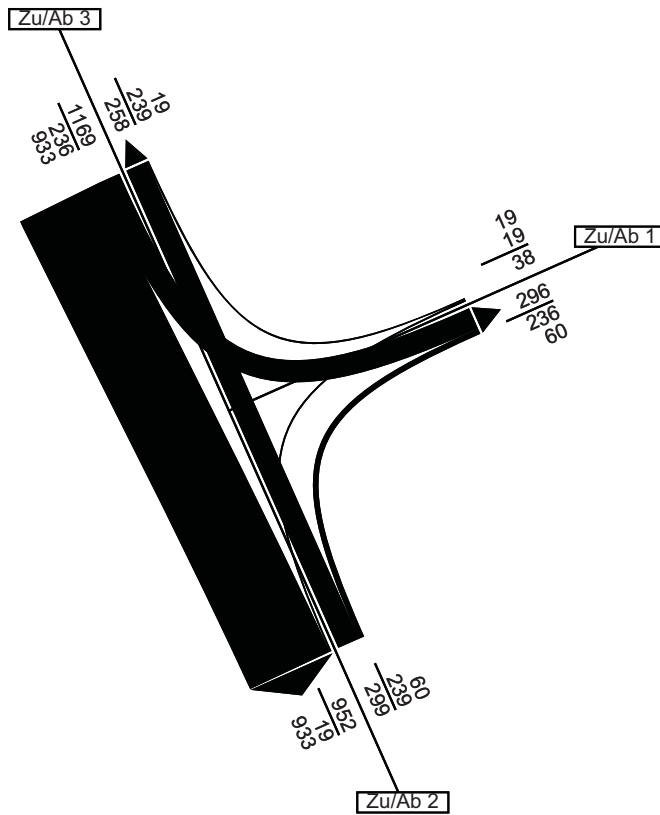

Spezifische Spitzenstunde abends  
16:45 Uhr - 17:45 Uhr in KFZ

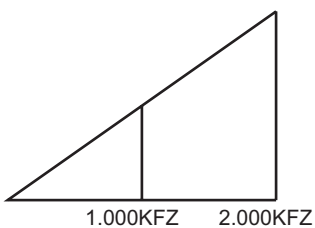
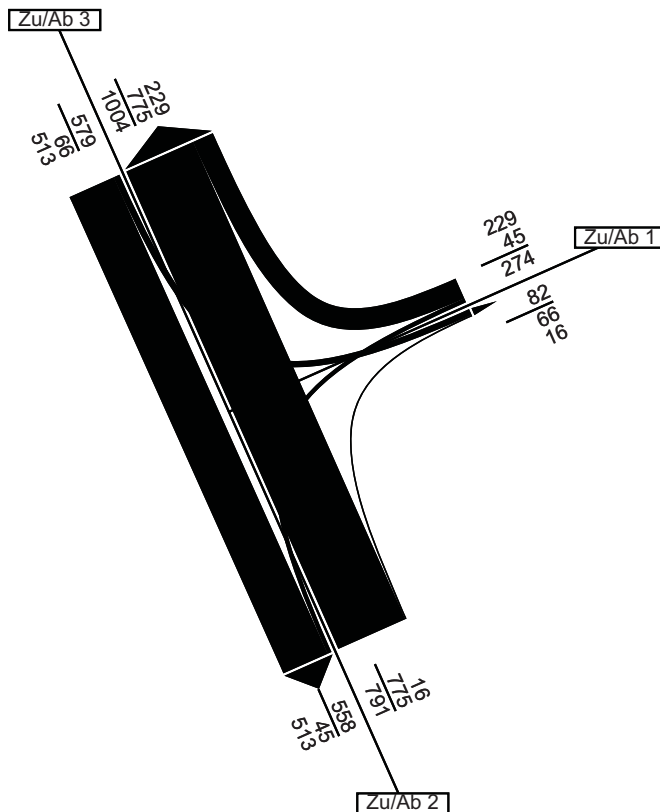

# Stadt Dachau

Zählstelle: K53 Fraunhoferstraße / Kopernikusstraße

Zu-/Ablauf 1: Kopernikusstr. (von/nach Norden)

Zu-/Ablauf 2: Privatzufahrt

Zu-/Ablauf 3: Kopernikusstr. (von/nach Süden)

Zu-/Ablauf 4: Fraunhoferstr.

Zusammenfassung Stundengruppen

Zähltag: Do., 08.05.2008

Zählzeit: 06:00 Uhr - 10:00 Uhr und 15:00 Uhr - 19:00 Uhr

## Summe Zählzeit (06:00 Uhr - 10:00 Uhr und 15:00 Uhr - 19:00 Uhr)

FZ-ART	1-2	1-3	1-4	2-1	2-3	2-4	3-1	3-2	3-4	4-1	4-2	4-3	Zu. 1	Zu. 2	Zu. 3	Zu. 4	Ab. 1	Ab. 2	Ab. 3	Ab. 4	K-Sum
RAD	0	15	7	0	0	0	29	0	53	32	0	48	22	0	82	80	61	0	63	60	184
KRAD	0	49	11	0	0	0	63	0	36	24	0	26	60	0	99	50	87	0	75	47	209
PKW	0	1214	465	0	0	0	1419	0	1189	443	0	900	1679	0	2608	1343	1862	0	2114	1654	5630
BUS	0	1	0	0	0	0	3	0	23	4	0	24	1	0	26	26	7	0	25	23	55
LFW	0	105	31	0	0	0	100	0	67	45	0	34	136	0	167	79	145	0	139	98	382
LKW	0	66	9	0	0	0	75	0	24	11	0	21	75	0	99	32	86	0	87	33	206
LZ	0	45	4	0	0	0	47	0	8	20	0	5	49	0	55	25	67	0	50	12	129
KFZ	0	1480	520	0	0	0	1707	0	1347	547	0	1010	2000	0	3054	1557	2254	0	2490	1867	6611
SV	0	112	13	0	0	0	125	0	55	35	0	50	125	0	180	85	160	0	162	68	390
PV	0	1264	476	0	0	0	1485	0	1248	471	0	950	1740	0	2733	1421	1956	0	2214	1724	5894
GV	0	216	44	0	0	0	222	0	99	76	0	60	260	0	321	136	298	0	276	143	717
<b>FZ-ART</b>	<b>1-2</b>	<b>1-3</b>	<b>1-4</b>	<b>2-1</b>	<b>2-3</b>	<b>2-4</b>	<b>3-1</b>	<b>3-2</b>	<b>3-4</b>	<b>4-1</b>	<b>4-2</b>	<b>4-3</b>	<b>Zu. 1</b>	<b>Zu. 2</b>	<b>Zu. 3</b>	<b>Zu. 4</b>	<b>Ab. 1</b>	<b>Ab. 2</b>	<b>Ab. 3</b>	<b>Ab. 4</b>	<b>K-Sum</b>

## Summe Zählintervall 06:00 Uhr - 10:00 Uhr

FZ-ART	1-2	1-3	1-4	2-1	2-3	2-4	3-1	3-2	3-4	4-1	4-2	4-3	Zu. 1	Zu. 2	Zu. 3	Zu. 4	Ab. 1	Ab. 2	Ab. 3	Ab. 4	K-Sum
RAD	0	2	0	0	0	0	10	0	11	11	0	7	2	0	21	18	21	0	9	11	41
KRAD	0	13	3	0	0	0	14	0	8	7	0	10	16	0	22	17	21	0	23	11	55
PKW	0	466	143	0	0	0	523	0	239	120	0	416	609	0	762	536	643	0	882	382	1907
BUS	0	0	0	0	0	0	1	0	11	1	0	11	0	0	12	12	2	0	11	11	24
LFW	0	44	15	0	0	0	35	0	29	23	0	24	59	0	64	47	58	0	68	44	170
LKW	0	33	7	0	0	0	33	0	14	5	0	12	40	0	47	17	38	0	45	21	104
LZ	0	24	2	0	0	0	21	0	3	9	0	3	26	0	24	12	30	0	27	5	62
KFZ	0	580	170	0	0	0	627	0	304	165	0	476	750	0	931	641	792	0	1056	474	2322
SV	0	57	9	0	0	0	55	0	28	15	0	26	66	0	83	41	70	0	83	37	190
PV	0	479	146	0	0	0	538	0	258	128	0	437	625	0	796	565	666	0	916	404	1986
GV	0	101	24	0	0	0	89	0	46	37	0	39	125	0	135	76	126	0	140	70	336
<b>FZ-ART</b>	<b>1-2</b>	<b>1-3</b>	<b>1-4</b>	<b>2-1</b>	<b>2-3</b>	<b>2-4</b>	<b>3-1</b>	<b>3-2</b>	<b>3-4</b>	<b>4-1</b>	<b>4-2</b>	<b>4-3</b>	<b>Zu. 1</b>	<b>Zu. 2</b>	<b>Zu. 3</b>	<b>Zu. 4</b>	<b>Ab. 1</b>	<b>Ab. 2</b>	<b>Ab. 3</b>	<b>Ab. 4</b>	<b>K-Sum</b>

## Summe Zählintervall 15:00 Uhr - 19:00 Uhr

FZ-ART	1-2	1-3	1-4	2-1	2-3	2-4	3-1	3-2	3-4	4-1	4-2	4-3	Zu. 1	Zu. 2	Zu. 3	Zu. 4	Ab. 1	Ab. 2	Ab. 3	Ab. 4	K-Sum
RAD	0	13	7	0	0	0	19	0	42	21	0	41	20	0	61	62	40	0	54	49	143
KRAD	0	36	8	0	0	0	49	0	28	17	0	16	44	0	77	33	66	0	52	36	154
PKW	0	748	322	0	0	0	896	0	950	323	0	484	1070	0	1846	807	1219	0	1232	1272	3723
BUS	0	1	0	0	0	0	2	0	12	3	0	13	1	0	14	16	5	0	14	12	31
LFW	0	61	16	0	0	0	65	0	38	22	0	10	77	0	103	32	87	0	71	54	212
LKW	0	33	2	0	0	0	42	0	10	6	0	9	35	0	52	15	48	0	42	12	102
LZ	0	21	2	0	0	0	26	0	5	11	0	2	23	0	31	13	37	0	23	7	67
KFZ	0	900	350	0	0	0	1080	0	1043	382	0	534	1250	0	2123	916	1462	0	1434	1393	4289
SV	0	55	4	0	0	0	70	0	27	20	0	24	59	0	97	44	90	0	79	31	200
PV	0	785	330	0	0	0	947	0	990	343	0	513	1115	0	1937	856	1290	0	1298	1320	3908
GV	0	115	20	0	0	0	133	0	53	39	0	21	135	0	186	60	172	0	136	73	381
<b>FZ-ART</b>	<b>1-2</b>	<b>1-3</b>	<b>1-4</b>	<b>2-1</b>	<b>2-3</b>	<b>2-4</b>	<b>3-1</b>	<b>3-2</b>	<b>3-4</b>	<b>4-1</b>	<b>4-2</b>	<b>4-3</b>	<b>Zu. 1</b>	<b>Zu. 2</b>	<b>Zu. 3</b>	<b>Zu. 4</b>	<b>Ab. 1</b>	<b>Ab. 2</b>	<b>Ab. 3</b>	<b>Ab. 4</b>	<b>K-Sum</b>

## spezifische Spitzenstunde morgens 09:00 Uhr - 10:00 Uhr

FZ-ART	1-2	1-3	1-4	2-1	2-3	2-4	3-1	3-2	3-4	4-1	4-2	4-3	Zu. 1	Zu. 2	Zu. 3	Zu. 4	Ab. 1	Ab. 2	Ab. 3	Ab. 4	K-Sum
RAD	0	0	0	0	0	0	3	0	6	5	0	2	0	0	9	7	8	0	2	6	16
KRAD	0	5	1	0	0	0	2	0	2	4	0	3	6	0	4	7	6	0	8	3	17
PKW	0	102	56	0	0	0	144	0	140	53	0	106	158	0	284	159	197	0	208	196	601
BUS	0	0	0	0	0	0	1	0	2	1	0	2	0	0	3	3	2	0	2	2	6
LFW	0	16	7	0	0	0	18	0	6	6	0	5	23	0	24	11	24	0	21	13	58
LKW	0	11	2	0	0	0	13	0	4	2	0	4	13	0	17	6	15	0	15	6	36
LZ	0	8	0	0	0	0	7	0	1	2	0	0	8	0	8	2	9	0	8	1	18
KFZ	0	142	66	0	0	0	185	0	155	68	0	120	208	0	340	188	253	0	262	221	736
SV	0	19	2	0	0	0	21	0	7	5	0	6	21	0	28	11	26	0	25	9	60
PV	0	107	57	0	0	0	147	0	144	58	0	111	164	0	291	169	205	0	218	201	624
GV	0	35	9	0	0	0	38	0	11	10	0	9	44	0	49	19	48	0	44	20	112
<b>FZ-ART</b>	<b>1-2</b>	<b>1-3</b>	<b>1-4</b>	<b>2-1</b>	<b>2-3</b>	<b>2-4</b>	<b>3-1</b>	<b>3-2</b>	<b>3-4</b>	<b>4-1</b>	<b>4-2</b>	<b>4-3</b>	<b>Zu. 1</b>	<b>Zu. 2</b>	<b>Zu. 3</b>	<b>Zu. 4</b>	<b>Ab. 1</b>	<b>Ab. 2</b>	<b>Ab. 3</b>	<b>Ab. 4</b>	<b>K-Sum</b>

## spezifische Spitzenstunde abends 16:15 Uhr - 17:15 Uhr

FZ-ART	1-2	1-3	1-4	2-1	2-3	2-4	3-1	3-2	3-4	4-1	4-2	4-3	Zu. 1	Zu. 2	Zu. 3	Zu. 4	Ab. 1	Ab. 2	Ab. 3	Ab. 4	K-Sum
RAD	0	2	0	0	0	0	5	0	18	3	0	13	2	0	23	16	8	0	15	18	41
KRAD	0	13	2	0	0	0	8	0	10	6	0	3	15	0	18	9	14	0	16	12	42
PKW	0	248	108	0	0	0	221	0	261	85	0	150	356	0	482	235	306	0	398	369	1073
BUS	0	0	0	0	0	0	0	0	3	0	0	2	0	0	3	2	0	0	2	3	5
LFW	0	16	4	0	0	0	24	0	11	5	0	2	20	0	35	7	29	0	18	15	62
LKW	0	9	0	0	0	0	8	0	3	2	0	3	9	0	11	5	10	0	12	3	25
LZ	0	10	0	0	0	0	7	0	1	4	0	1	10	0	8	5	11	0	11	1	23
KFZ	0	296	114	0	0	0	268	0	289	102											

# Stadt Dachau

Zählstelle: K53 Fraunhoferstraße / Kopernikusstraße

Zusammenfassung Stundengruppen

Zähltag: Do., 08.05.2008

Zählzeit: 06:00 Uhr - 10:00 Uhr und 15:00 Uhr - 19:00 Uhr

Zu-/Ablauf 1: Kopernikusstr. (von/nach Norden)

Zu-/Ablauf 2: Privatzufahrt

Zu-/Ablauf 3: Kopernikusstr. (von/nach Süden)

Zu-/Ablauf 4: Fraunhoferstr.

Spezifische Spitzenstunde morgens  
09:00 Uhr - 10:00 Uhr in KFZ

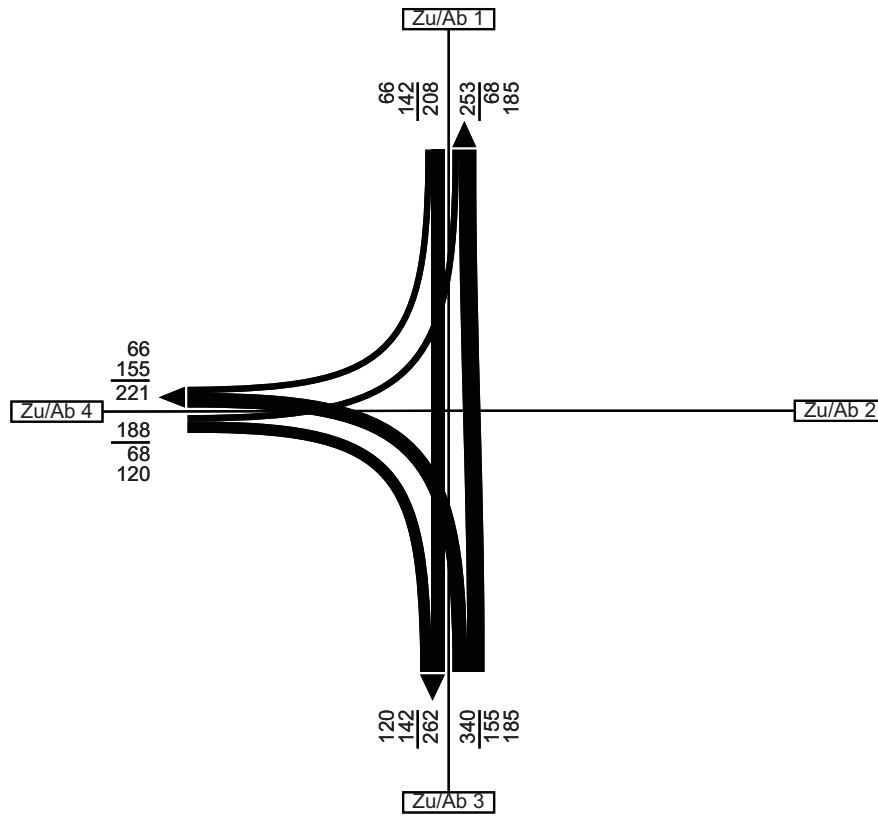

Spezifische Spitzenstunde abends  
16:15 Uhr - 17:15 Uhr in KFZ

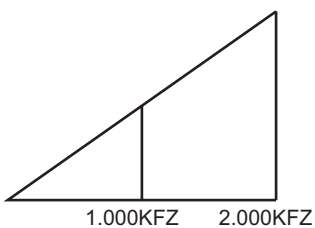
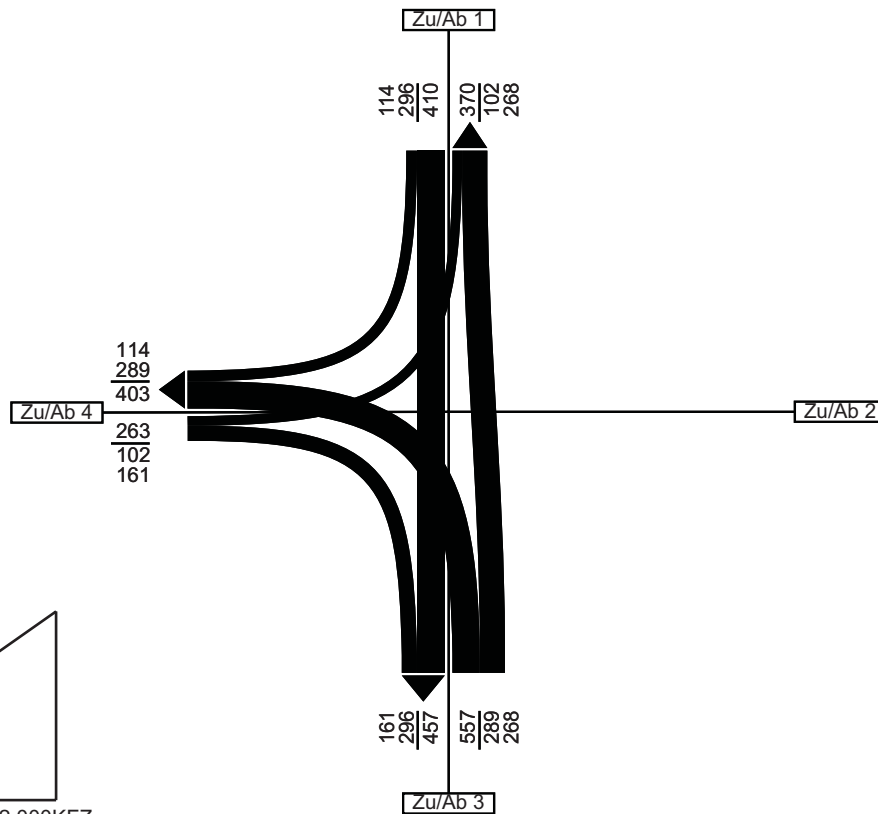

# Stadt Dachau

Zählstelle: K54 Sudetenlandstraße / Würmstraße

Zu-/Ablauf 1: Sudetenlandstr. (von/nach Osten)

Zu-/Ablauf 2: Würmstr.

Zu-/Ablauf 3: Sudetenlandstr. (von/nach Westen)

Zusammenfassung Stundengruppen

Zähltag: Do., 08.05.2008

Zählzeit: 06:00 Uhr - 10:00 Uhr und 15:00 Uhr - 19:00 Uhr

## Summe Zählzeit (06:00 Uhr - 10:00 Uhr und 15:00 Uhr - 19:00 Uhr)

FZ-ART	1-2	1-3	1-4	2-1	2-3	2-4	3-1	3-2	3-4	4-1	4-2	4-3	Zu. 1	Zu. 2	Zu. 3	Zu. 4	Ab. 1	Ab. 2	Ab. 3	Ab. 4	K-Sum
RAD	18	247	0	29	15	0	188	39	0	0	0	0	265	44	227	0	217	57	262	0	536
KRAD	28	96	0	30	9	0	70	11	0	0	0	0	124	39	81	0	100	39	105	0	244
PKW	789	3069	0	752	226	0	3353	369	0	0	0	0	3858	978	3722	0	4105	1158	3295	0	8558
BUS	31	2	0	23	25	0	3	25	0	0	0	0	33	48	28	0	26	56	27	0	109
LFW	42	167	0	44	13	0	154	22	0	0	0	0	209	57	176	0	198	64	180	0	442
LKW	13	72	0	6	0	0	23	2	0	0	0	0	85	6	25	0	29	15	72	0	116
LZ	9	10	0	5	0	0	46	0	0	0	0	0	19	5	46	0	51	9	10	0	70
<b>KFZ</b>	<b>912</b>	<b>3416</b>	<b>0</b>	<b>860</b>	<b>273</b>	<b>0</b>	<b>3649</b>	<b>429</b>	<b>0</b>	<b>0</b>	<b>0</b>	<b>0</b>	<b>4328</b>	<b>1133</b>	<b>4078</b>	<b>0</b>	<b>4509</b>	<b>1341</b>	<b>3689</b>	<b>0</b>	<b>9539</b>
SV	53	84	0	34	25	0	72	27	0	0	0	0	137	59	99	0	106	80	109	0	295
PV	848	3167	0	805	260	0	3426	405	0	0	0	0	4015	1065	3831	0	4231	1253	3427	0	8911
GV	64	249	0	55	13	0	223	24	0	0	0	0	313	68	247	0	278	88	262	0	628
<b>FZ-ART</b>	<b>1-2</b>	<b>1-3</b>	<b>1-4</b>	<b>2-1</b>	<b>2-3</b>	<b>2-4</b>	<b>3-1</b>	<b>3-2</b>	<b>3-4</b>	<b>4-1</b>	<b>4-2</b>	<b>4-3</b>	<b>Zu. 1</b>	<b>Zu. 2</b>	<b>Zu. 3</b>	<b>Zu. 4</b>	<b>Ab. 1</b>	<b>Ab. 2</b>	<b>Ab. 3</b>	<b>Ab. 4</b>	<b>K-Sum</b>

## Summe Zählintervall 06:00 Uhr - 10:00 Uhr

FZ-ART	1-2	1-3	1-4	2-1	2-3	2-4	3-1	3-2	3-4	4-1	4-2	4-3	Zu. 1	Zu. 2	Zu. 3	Zu. 4	Ab. 1	Ab. 2	Ab. 3	Ab. 4	K-Sum
RAD	8	49	0	16	12	0	78	13	0	0	0	0	57	28	91	0	94	21	61	0	176
KRAD	9	19	0	8	4	0	27	5	0	0	0	0	28	12	32	0	35	14	23	0	72
PKW	291	801	0	384	100	0	1637	168	0	0	0	0	1092	484	1805	0	2021	459	901	0	3381
BUS	16	1	0	11	13	0	2	13	0	0	0	0	17	24	15	0	13	29	14	0	56
LFW	20	84	0	20	5	0	98	9	0	0	0	0	104	25	107	0	118	29	89	0	236
LKW	10	38	0	2	0	0	11	2	0	0	0	0	48	2	13	0	13	12	38	0	63
LZ	4	6	0	1	0	0	26	0	0	0	0	0	10	1	26	0	27	4	6	0	37
<b>KFZ</b>	<b>350</b>	<b>949</b>	<b>0</b>	<b>426</b>	<b>122</b>	<b>0</b>	<b>1801</b>	<b>197</b>	<b>0</b>	<b>0</b>	<b>0</b>	<b>0</b>	<b>1299</b>	<b>548</b>	<b>1998</b>	<b>0</b>	<b>2227</b>	<b>547</b>	<b>1071</b>	<b>0</b>	<b>3845</b>
SV	30	45	0	14	13	0	39	15	0	0	0	0	75	27	54	0	53	45	58	0	156
PV	316	821	0	403	117	0	1666	186	0	0	0	0	1137	520	1852	0	2069	502	938	0	3509
GV	34	128	0	23	5	0	135	11	0	0	0	0	162	28	146	0	158	45	133	0	336
<b>FZ-ART</b>	<b>1-2</b>	<b>1-3</b>	<b>1-4</b>	<b>2-1</b>	<b>2-3</b>	<b>2-4</b>	<b>3-1</b>	<b>3-2</b>	<b>3-4</b>	<b>4-1</b>	<b>4-2</b>	<b>4-3</b>	<b>Zu. 1</b>	<b>Zu. 2</b>	<b>Zu. 3</b>	<b>Zu. 4</b>	<b>Ab. 1</b>	<b>Ab. 2</b>	<b>Ab. 3</b>	<b>Ab. 4</b>	<b>K-Sum</b>

## Summe Zählintervall 15:00 Uhr - 19:00 Uhr

FZ-ART	1-2	1-3	1-4	2-1	2-3	2-4	3-1	3-2	3-4	4-1	4-2	4-3	Zu. 1	Zu. 2	Zu. 3	Zu. 4	Ab. 1	Ab. 2	Ab. 3	Ab. 4	K-Sum
RAD	10	198	0	13	3	0	110	26	0	0	0	0	208	16	136	0	123	36	201	0	360
KRAD	19	77	0	22	5	0	43	6	0	0	0	0	96	27	49	0	65	25	82	0	172
PKW	498	2268	0	368	126	0	1716	201	0	0	0	0	2766	494	1917	0	2084	699	2394	0	5177
BUS	15	1	0	12	12	0	1	12	0	0	0	0	16	24	13	0	13	27	13	0	53
LFW	22	83	0	24	8	0	56	13	0	0	0	0	105	32	69	0	80	35	91	0	206
LKW	3	34	0	4	0	0	12	0	0	0	0	0	37	4	12	0	16	3	34	0	53
LZ	5	4	0	4	0	0	20	0	0	0	0	0	9	4	20	0	24	5	4	0	33
<b>KFZ</b>	<b>562</b>	<b>2467</b>	<b>0</b>	<b>434</b>	<b>151</b>	<b>0</b>	<b>1848</b>	<b>232</b>	<b>0</b>	<b>0</b>	<b>0</b>	<b>0</b>	<b>3029</b>	<b>585</b>	<b>2080</b>	<b>0</b>	<b>2282</b>	<b>794</b>	<b>2618</b>	<b>0</b>	<b>5694</b>
SV	23	39	0	20	12	0	33	12	0	0	0	0	62	32	45	0	53	35	51	0	139
PV	532	2346	0	402	143	0	1760	219	0	0	0	0	2878	545	1979	0	2162	751	2489	0	5402
GV	30	121	0	32	8	0	88	13	0	0	0	0	151	40	101	0	120	43	129	0	292
<b>FZ-ART</b>	<b>1-2</b>	<b>1-3</b>	<b>1-4</b>	<b>2-1</b>	<b>2-3</b>	<b>2-4</b>	<b>3-1</b>	<b>3-2</b>	<b>3-4</b>	<b>4-1</b>	<b>4-2</b>	<b>4-3</b>	<b>Zu. 1</b>	<b>Zu. 2</b>	<b>Zu. 3</b>	<b>Zu. 4</b>	<b>Ab. 1</b>	<b>Ab. 2</b>	<b>Ab. 3</b>	<b>Ab. 4</b>	<b>K-Sum</b>

## spezifische Spitzenstunde morgens 09:00 Uhr - 10:00 Uhr

FZ-ART	1-2	1-3	1-4	2-1	2-3	2-4	3-1	3-2	3-4	4-1	4-2	4-3	Zu. 1	Zu. 2	Zu. 3	Zu. 4	Ab. 1	Ab. 2	Ab. 3	Ab. 4	K-Sum
RAD	1	17	0	6	2	0	33	6	0	0	0	0	18	8	39	0	39	7	19	0	65
KRAD	0	8	0	1	0	0	4	0	0	0	0	0	8	1	4	0	5	0	8	0	13
PKW	75	322	0	105	45	0	464	47	0	0	0	0	397	150	511	0	569	122	367	0	1058
BUS	3	1	0	3	3	0	0	3	0	0	0	0	4	6	3	0	3	6	4	0	13
LFW	3	23	0	5	1	0	25	3	0	0	0	0	26	6	28	0	30	6	24	0	60
LKW	1	12	0	0	0	0	4	0	0	0	0	0	13	0	4	0	4	1	12	0	17
LZ	1	2	0	0	0	0	10	0	0	0	0	0	3	0	10	0	10	1	2	0	13
<b>KFZ</b>	<b>83</b>	<b>368</b>	<b>0</b>	<b>114</b>	<b>49</b>	<b>0</b>	<b>507</b>	<b>53</b>	<b>0</b>	<b>0</b>	<b>0</b>	<b>0</b>	<b>451</b>	<b>163</b>	<b>560</b>	<b>0</b>	<b>621</b>	<b>136</b>	<b>417</b>	<b>0</b>	<b>1174</b>
SV	5	15	0	3	3	0	14	3	0	0	0	0	20	6	17	0	17	8	18	0	43
PV	78	331	0	109	48	0	468	50	0	0	0	0	409	157	518	0	577	128	379	0	1084
GV	5	37	0	5	1	0	39	3	0	0	0	0	42	6	42	0	44	8	38	0	90
<b>FZ-ART</b>	<b>1-2</b>	<b>1-3</b>	<b>1-4</b>	<b>2-1</b>	<b>2-3</b>	<b>2-4</b>	<b>3-1</b>	<b>3-2</b>	<b>3-4</b>	<b>4-1</b>	<b>4-2</b>	<b>4-3</b>	<b>Zu. 1</b>	<b>Zu. 2</b>	<b>Zu. 3</b>	<b>Zu. 4</b>	<b>Ab. 1</b>	<b>Ab. 2</b>	<b>Ab. 3</b>	<b>Ab. 4</b>	<b>K-Sum</b>

## spezifische Spitzenstunde abends 16:30 Uhr - 17:30 Uhr

FZ-ART	1-2	1-3	1-4	2-1	2-3	2-4	3-1	3-2	3-4	4-1	4-2	4-3	Zu. 1	Zu. 2	Zu. 3	Zu. 4	Ab. 1	Ab. 2	Ab. 3	Ab. 4	K-Sum
RAD	2	63	0	5	0	0	20	4	0	0	0	0	65	5	24	0	25	6	63	0	94
KRAD	7	17	0	4	3	0	6	1	0	0	0	0	24	7	7	0	10	8	20	0	38
PKW	170	670	0	109	32	0	476	52	0	0	0	0	840	141	528	0	585	222	702	0	1509
BUS	4	0	0	2	3	0	0	3	0	0	0	0	4	5	3	0	2	7	3	0	12
LFW	9	29	0	4	2	0	10	1	0	0	0	0	38	6	11	0	14	10	31	0	55
LKW	0	5	0	1	0	0	1	0	0	0	0	0	5	1							

# Stadt Dachau

Zählstelle: K54 Sudetenlandstraße / Würmstraße

Zusammenfassung Stundengruppen

Zähltag: Do., 08.05.2008

Zählzeit: 06:00 Uhr - 10:00 Uhr und 15:00 Uhr - 19:00 Uhr

Zu-/Ablauf 1: Sudetenlandstr. (von/nach Osten)

Zu-/Ablauf 2: Würmstr.

Zu-/Ablauf 3: Sudetenlandstr. (von/nach Westen)

Spezifische Spitzenstunde morgens  
09:00 Uhr - 10:00 Uhr in KFZ

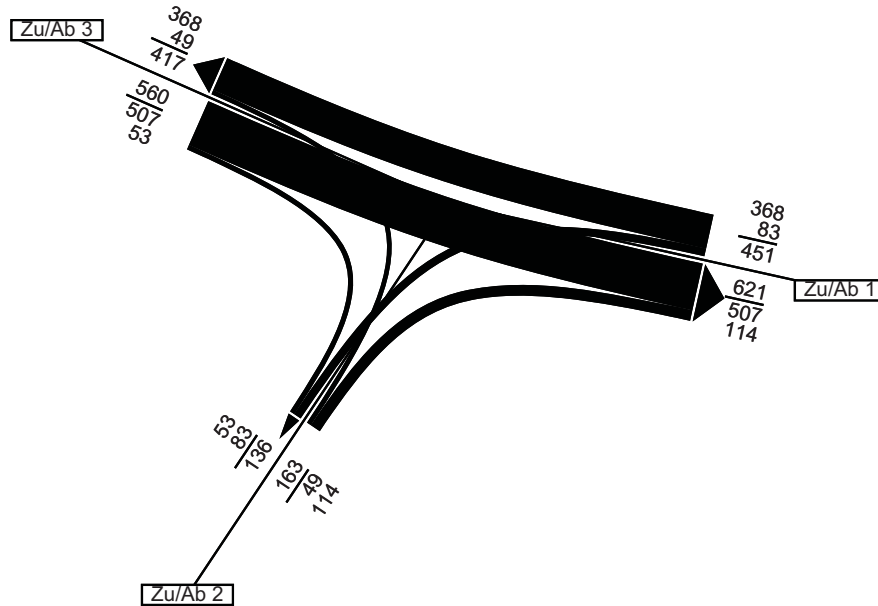

Spezifische Spitzenstunde abends  
16:30 Uhr - 17:30 Uhr in KFZ

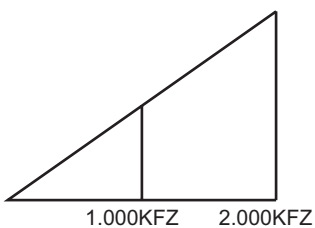
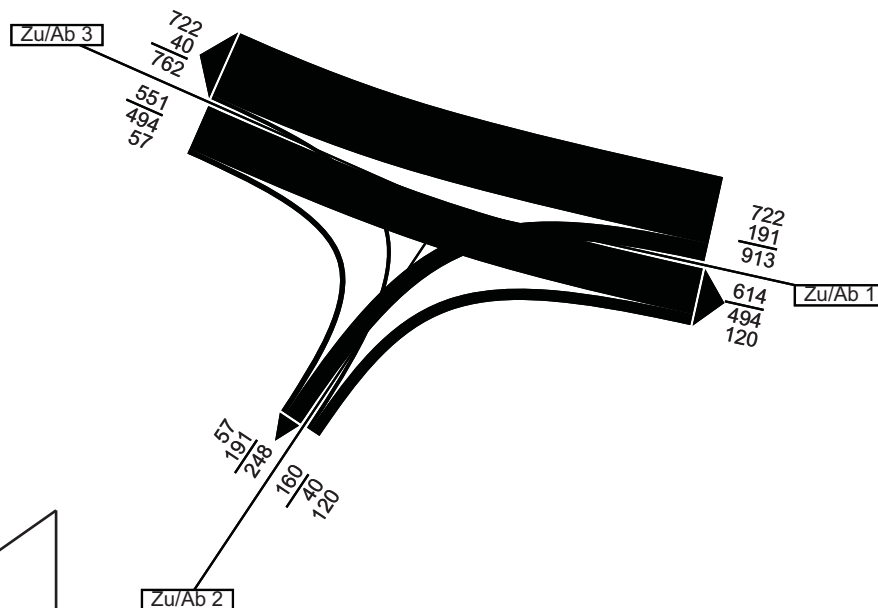

# Stadt Dachau

Zählstelle: K55 Erich-Ollenhauer-Straße / Ostenstraße

Zu-/Ablauf 1: Erich-Ollenhauer-Str. (von/nach Osten)

Zu-/Ablauf 2: Ostenstr.

Zu-/Ablauf 3: Erich-Ollenhauer-Str. (von/nach Westen)

Zusammenfassung Stundengruppen

Zähltag: Do., 08.05.2008

Zählzeit: 06:00 Uhr - 10:00 Uhr und 15:00 Uhr - 19:00 Uhr

## Summe Zählzeit (06:00 Uhr - 10:00 Uhr und 15:00 Uhr - 19:00 Uhr)

FZ-ART	1-2	1-3	1-4	2-1	2-3	2-4	3-1	3-2	3-4	4-1	4-2	4-3	Zu. 1	Zu. 2	Zu. 3	Zu. 4	Ab. 1	Ab. 2	Ab. 3	Ab. 4	K-Sum
RAD	70	317	0	80	6	0	498	5	0	0	0	0	387	86	503	0	578	75	323	0	976
KRAD	9	119	0	16	4	0	118	6	0	0	0	0	128	20	124	0	134	15	123	0	272
PKW	396	3246	0	483	69	0	3234	133	0	0	0	0	3642	552	3367	0	3717	529	3315	0	7561
BUS	0	59	0	2	1	0	72	0	0	0	0	0	59	3	72	0	74	0	60	0	134
LFW	24	191	0	37	5	0	203	6	0	0	0	0	215	42	209	0	240	30	196	0	466
LKW	3	125	0	2	3	0	91	1	0	0	0	0	128	5	92	0	93	4	128	0	225
LZ	1	72	0	2	0	0	59	0	0	0	0	0	73	2	59	0	61	1	72	0	134
<b>KFZ</b>	<b>433</b>	<b>3812</b>	<b>0</b>	<b>542</b>	<b>82</b>	<b>0</b>	<b>3777</b>	<b>146</b>	<b>0</b>	<b>0</b>	<b>0</b>	<b>0</b>	<b>4245</b>	<b>624</b>	<b>3923</b>	<b>0</b>	<b>4319</b>	<b>579</b>	<b>3894</b>	<b>0</b>	<b>8792</b>
SV	4	256	0	6	4	0	222	1	0	0	0	0	260	10	223	0	228	5	260	0	493
PV	405	3424	0	501	74	0	3424	139	0	0	0	0	3829	575	3563	0	3925	544	3498	0	7967
GV	28	388	0	41	8	0	353	7	0	0	0	0	416	49	360	0	394	35	396	0	825
<b>FZ-ART</b>	<b>1-2</b>	<b>1-3</b>	<b>1-4</b>	<b>2-1</b>	<b>2-3</b>	<b>2-4</b>	<b>3-1</b>	<b>3-2</b>	<b>3-4</b>	<b>4-1</b>	<b>4-2</b>	<b>4-3</b>	<b>Zu. 1</b>	<b>Zu. 2</b>	<b>Zu. 3</b>	<b>Zu. 4</b>	<b>Ab. 1</b>	<b>Ab. 2</b>	<b>Ab. 3</b>	<b>Ab. 4</b>	<b>K-Sum</b>

## Summe Zählintervall 06:00 Uhr - 10:00 Uhr

FZ-ART	1-2	1-3	1-4	2-1	2-3	2-4	3-1	3-2	3-4	4-1	4-2	4-3	Zu. 1	Zu. 2	Zu. 3	Zu. 4	Ab. 1	Ab. 2	Ab. 3	Ab. 4	K-Sum
RAD	14	77	0	40	0	0	322	2	0	0	0	0	91	40	324	0	362	16	77	0	455
KRAD	3	21	0	5	0	0	63	2	0	0	0	0	24	5	65	0	68	5	21	0	94
PKW	125	967	0	222	20	0	1806	68	0	0	0	0	1092	242	1874	0	2028	193	987	0	3208
BUS	0	33	0	1	0	0	47	0	0	0	0	0	33	1	47	0	48	0	33	0	81
LFW	19	88	0	21	1	0	139	2	0	0	0	0	107	22	141	0	160	21	89	0	270
LKW	2	60	0	1	2	0	68	1	0	0	0	0	62	3	69	0	69	3	62	0	134
LZ	0	25	0	0	0	0	32	0	0	0	0	0	25	0	32	0	32	0	25	0	57
<b>KFZ</b>	<b>149</b>	<b>1194</b>	<b>0</b>	<b>250</b>	<b>23</b>	<b>0</b>	<b>2155</b>	<b>73</b>	<b>0</b>	<b>0</b>	<b>0</b>	<b>0</b>	<b>1343</b>	<b>273</b>	<b>2228</b>	<b>0</b>	<b>2405</b>	<b>222</b>	<b>1217</b>	<b>0</b>	<b>3844</b>
SV	2	118	0	2	2	0	147	1	0	0	0	0	120	4	148	0	149	3	120	0	272
PV	128	1021	0	228	20	0	1916	70	0	0	0	0	1149	248	1986	0	2144	198	1041	0	3383
GV	21	173	0	22	3	0	239	3	0	0	0	0	194	25	242	0	261	24	176	0	461
<b>FZ-ART</b>	<b>1-2</b>	<b>1-3</b>	<b>1-4</b>	<b>2-1</b>	<b>2-3</b>	<b>2-4</b>	<b>3-1</b>	<b>3-2</b>	<b>3-4</b>	<b>4-1</b>	<b>4-2</b>	<b>4-3</b>	<b>Zu. 1</b>	<b>Zu. 2</b>	<b>Zu. 3</b>	<b>Zu. 4</b>	<b>Ab. 1</b>	<b>Ab. 2</b>	<b>Ab. 3</b>	<b>Ab. 4</b>	<b>K-Sum</b>

## Summe Zählintervall 15:00 Uhr - 19:00 Uhr

FZ-ART	1-2	1-3	1-4	2-1	2-3	2-4	3-1	3-2	3-4	4-1	4-2	4-3	Zu. 1	Zu. 2	Zu. 3	Zu. 4	Ab. 1	Ab. 2	Ab. 3	Ab. 4	K-Sum
RAD	56	240	0	40	6	0	176	3	0	0	0	0	296	46	179	0	216	59	246	0	521
KRAD	6	98	0	11	4	0	55	4	0	0	0	0	104	15	59	0	66	10	102	0	178
PKW	271	2279	0	261	49	0	1428	65	0	0	0	0	2550	310	1493	0	1689	336	2328	0	4353
BUS	0	26	0	1	1	0	25	0	0	0	0	0	26	2	25	0	26	0	27	0	53
LFW	5	103	0	16	4	0	64	4	0	0	0	0	108	20	68	0	80	9	107	0	196
LKW	1	65	0	1	1	0	23	0	0	0	0	0	66	2	23	0	24	1	66	0	91
LZ	1	47	0	2	0	0	27	0	0	0	0	0	48	2	27	0	29	1	47	0	77
<b>KFZ</b>	<b>284</b>	<b>2618</b>	<b>0</b>	<b>292</b>	<b>59</b>	<b>0</b>	<b>1622</b>	<b>73</b>	<b>0</b>	<b>0</b>	<b>0</b>	<b>0</b>	<b>2902</b>	<b>351</b>	<b>1695</b>	<b>0</b>	<b>1914</b>	<b>357</b>	<b>2677</b>	<b>0</b>	<b>4948</b>
SV	2	138	0	4	2	0	75	0	0	0	0	0	140	6	75	0	79	2	140	0	221
PV	277	2403	0	273	54	0	1508	69	0	0	0	0	2680	327	1577	0	1781	346	2457	0	4584
GV	7	215	0	19	5	0	114	4	0	0	0	0	222	24	118	0	133	11	220	0	364
<b>FZ-ART</b>	<b>1-2</b>	<b>1-3</b>	<b>1-4</b>	<b>2-1</b>	<b>2-3</b>	<b>2-4</b>	<b>3-1</b>	<b>3-2</b>	<b>3-4</b>	<b>4-1</b>	<b>4-2</b>	<b>4-3</b>	<b>Zu. 1</b>	<b>Zu. 2</b>	<b>Zu. 3</b>	<b>Zu. 4</b>	<b>Ab. 1</b>	<b>Ab. 2</b>	<b>Ab. 3</b>	<b>Ab. 4</b>	<b>K-Sum</b>

## spezifische Spitzenstunde morgens 07:45 Uhr - 08:45 Uhr

FZ-ART	1-2	1-3	1-4	2-1	2-3	2-4	3-1	3-2	3-4	4-1	4-2	4-3	Zu. 1	Zu. 2	Zu. 3	Zu. 4	Ab. 1	Ab. 2	Ab. 3	Ab. 4	K-Sum
RAD	3	25	0	16	0	0	186	0	0	0	0	0	28	16	186	0	202	3	25	0	230
KRAD	1	4	0	2	0	0	15	1	0	0	0	0	5	2	16	0	17	2	4	0	23
PKW	49	229	0	60	6	0	544	23	0	0	0	0	278	66	567	0	604	72	235	0	911
BUS	0	9	0	0	0	0	14	0	0	0	0	0	9	0	14	0	14	0	9	0	23
LFW	9	30	0	7	1	0	37	1	0	0	0	0	39	8	38	0	44	10	31	0	85
LKW	0	24	0	0	0	0	20	0	0	0	0	0	24	0	20	0	20	0	24	0	44
LZ	0	7	0	0	0	0	9	0	0	0	0	0	7	0	9	0	9	0	7	0	16
<b>KFZ</b>	<b>59</b>	<b>303</b>	<b>0</b>	<b>69</b>	<b>7</b>	<b>0</b>	<b>639</b>	<b>25</b>	<b>0</b>	<b>0</b>	<b>0</b>	<b>0</b>	<b>362</b>	<b>76</b>	<b>664</b>	<b>0</b>	<b>708</b>	<b>84</b>	<b>310</b>	<b>0</b>	<b>1102</b>
SV	0	40	0	0	0	0	43	0	0	0	0	0	40	0	43	0	43	0	40	0	83
PV	50	242	0	62	6	0	573	24	0	0	0	0	292	68	597	0	635	74	248	0	957
GV	9	61	0	7	1	0	66	1	0	0	0	0	70	8	67	0	73	10	62	0	145
<b>FZ-ART</b>	<b>1-2</b>	<b>1-3</b>	<b>1-4</b>	<b>2-1</b>	<b>2-3</b>	<b>2-4</b>	<b>3-1</b>	<b>3-2</b>	<b>3-4</b>	<b>4-1</b>	<b>4-2</b>	<b>4-3</b>	<b>Zu. 1</b>	<b>Zu. 2</b>	<b>Zu. 3</b>	<b>Zu. 4</b>	<b>Ab. 1</b>	<b>Ab. 2</b>	<b>Ab. 3</b>	<b>Ab. 4</b>	<b>K-Sum</b>

## spezifische Spitzenstunde abends 17:15 Uhr - 18:15 Uhr

FZ-ART	1-2	1-3	1-4	2-1	2-3	2-4	3-1	3-2	3-4	4-1	4-2	4-3	Zu. 1	Zu. 2	Zu. 3	Zu. 4	Ab. 1	Ab. 2	Ab. 3	Ab. 4	K-Sum
RAD	13	65	0	7	3	0	41	0	0	0	0	0	78	10	41	0	48	13	68	0	129
KRAD	1	24	0	3	2	0	11	3	0	0	0	0	25	5	14	0	14	4	26	0	44
PKW	84	675	0	56	11	0	429	18	0	0	0	0	759	67	447	0	485	102	686	0	1273
BUS	0	4	0	0	1	0	7	0	0	0	0	0	4	1	7	0	7	0	5	0	12
LFW	0	29	0	2	1	0	15	0	0	0	0	0	29	3	15	0	17	0	30	0	47
LKW	0	13	0	0	0	0	6	0	0	0	0	0	13	0	6	0	6				

# Stadt Dachau

Zählstelle: K55 Erich-Ollenhauer-Straße / Ostenstraße

Zusammenfassung Stundengruppen

Zähltag: Do., 08.05.2008

Zählzeit: 06:00 Uhr - 10:00 Uhr und 15:00 Uhr - 19:00 Uhr

Zu-/Ablauf 1: Erich-Ollenhauer-Str. (von/nach Osten)

Zu-/Ablauf 2: Ostenstr.

Zu-/Ablauf 3: Erich-Ollenhauer-Str. (von/nach Westen)

Spezifische Spitzenstunde morgens  
07:45 Uhr - 08:45 Uhr in KFZ

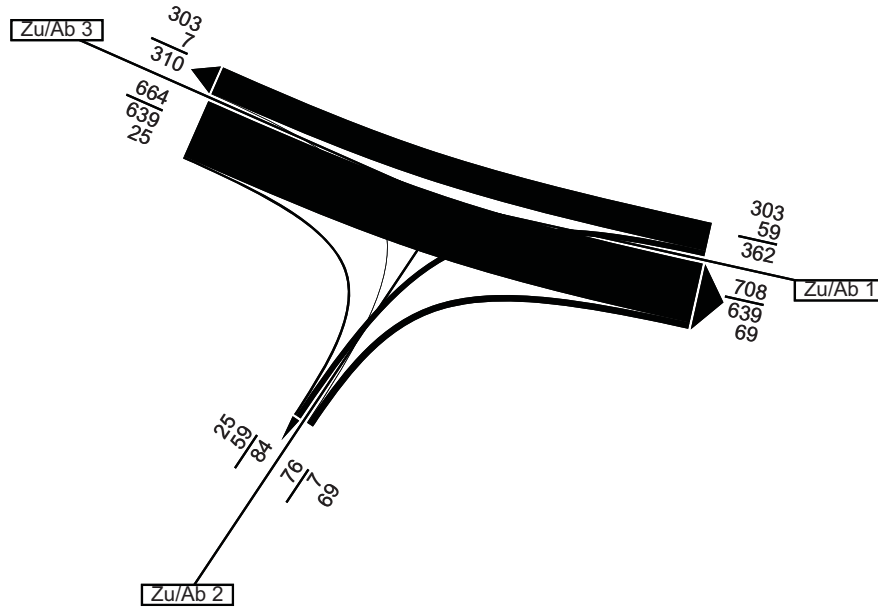

Spezifische Spitzenstunde abends  
17:15 Uhr - 18:15 Uhr in KFZ

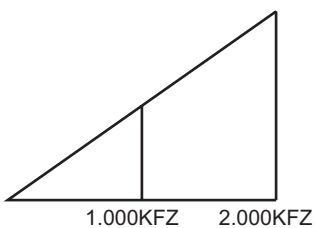
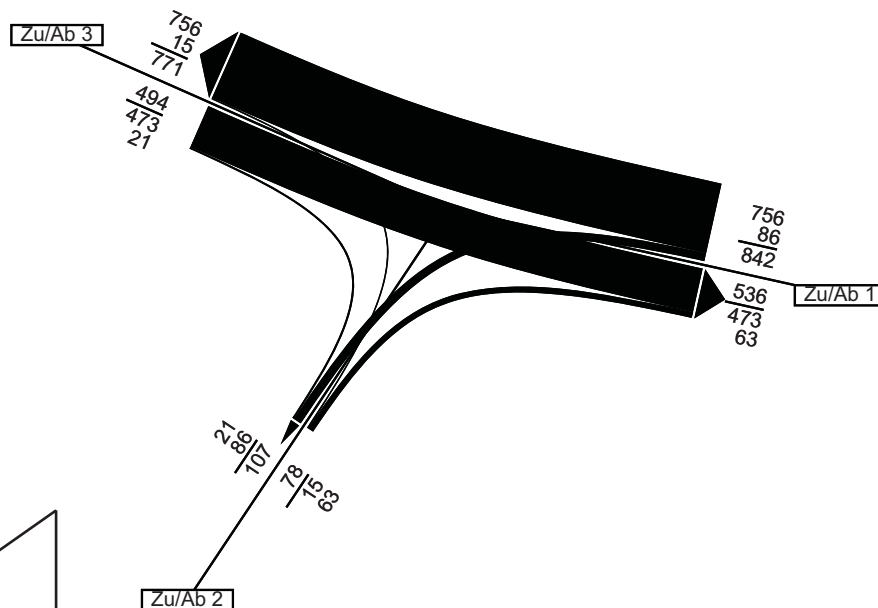

**Stadt Dachau**

Zählstelle: K56 Schleißheimer Straße / Friedenstraße

Zu-/Ablauf 1: Friedenstr.

Zu-/Ablauf 2: Schleißheimer Str. (von/nach Stadtauswärts)

Zu-/Ablauf 3: Schleißheimer Str. (von/nach Stadteinwärts)

Zusammenfassung Stundengruppen

Zähltag: Do., 08.05.2008

Zählzeit: 06:00 Uhr - 10:00 Uhr und 15:00 Uhr - 19:00 Uhr

**Summe Zählzeit (06:00 Uhr - 10:00 Uhr und 15:00 Uhr - 19:00 Uhr)**

FZ-ART	1-2	1-3	1-4	2-1	2-3	2-4	3-1	3-2	3-4	4-1	4-2	4-3	Zu. 1	Zu. 2	Zu. 3	Zu. 4	Ab. 1	Ab. 2	Ab. 3	Ab. 4	K-Sum
RAD	78	252	0	93	213	0	141	303	0	0	0	0	330	306	444	0	234	381	465	0	1080
KRAD	4	32	0	7	95	0	28	120	0	0	0	0	36	102	148	0	35	124	127	0	286
PKW	206	764	0	184	2860	0	665	3443	0	0	0	0	970	3044	4108	0	849	3649	3624	0	8122
BUS	0	33	0	3	77	0	26	70	0	0	0	0	33	80	96	0	29	70	110	0	209
LFW	6	47	0	20	232	0	27	180	0	0	0	0	53	252	207	0	47	186	279	0	512
LKW	2	4	0	13	35	0	5	40	0	0	0	0	6	48	45	0	18	42	39	0	99
LZ	13	6	0	5	13	0	4	12	0	0	0	0	19	18	16	0	9	25	19	0	53
<b>KFZ</b>	<b>231</b>	<b>886</b>	<b>0</b>	<b>232</b>	<b>3312</b>	<b>0</b>	<b>755</b>	<b>3865</b>	<b>0</b>	<b>0</b>	<b>0</b>	<b>0</b>	<b>1117</b>	<b>3544</b>	<b>4620</b>	<b>0</b>	<b>987</b>	<b>4096</b>	<b>4198</b>	<b>0</b>	<b>9281</b>
SV	15	43	0	21	125	0	35	122	0	0	0	0	58	146	157	0	56	137	168	0	361
PV	210	829	0	194	3032	0	719	3633	0	0	0	0	1039	3226	4352	0	913	3843	3861	0	8617
GV	21	57	0	38	280	0	36	232	0	0	0	0	78	318	268	0	74	253	337	0	664
<b>FZ-ART</b>	<b>1-2</b>	<b>1-3</b>	<b>1-4</b>	<b>2-1</b>	<b>2-3</b>	<b>2-4</b>	<b>3-1</b>	<b>3-2</b>	<b>3-4</b>	<b>4-1</b>	<b>4-2</b>	<b>4-3</b>	<b>Zu. 1</b>	<b>Zu. 2</b>	<b>Zu. 3</b>	<b>Zu. 4</b>	<b>Ab. 1</b>	<b>Ab. 2</b>	<b>Ab. 3</b>	<b>Ab. 4</b>	<b>K-Sum</b>

**Summe Zählintervall 06:00 Uhr - 10:00 Uhr**

FZ-ART	1-2	1-3	1-4	2-1	2-3	2-4	3-1	3-2	3-4	4-1	4-2	4-3	Zu. 1	Zu. 2	Zu. 3	Zu. 4	Ab. 1	Ab. 2	Ab. 3	Ab. 4	K-Sum
RAD	51	77	0	85	87	0	118	111	0	0	0	0	128	172	229	0	203	162	164	0	529
KRAD	0	8	0	2	11	0	13	33	0	0	0	0	8	13	46	0	15	33	19	0	67
PKW	145	323	0	62	1064	0	265	1518	0	0	0	0	468	1126	1783	0	327	1663	1387	0	3377
BUS	0	19	0	2	49	0	14	44	0	0	0	0	19	51	58	0	16	44	68	0	128
LFW	4	29	0	8	115	0	22	94	0	0	0	0	33	123	116	0	30	98	144	0	272
LKW	1	3	0	7	25	0	4	23	0	0	0	0	4	32	27	0	11	24	28	0	63
LZ	8	6	0	4	11	0	2	8	0	0	0	0	14	15	10	0	6	16	17	0	39
<b>KFZ</b>	<b>158</b>	<b>388</b>	<b>0</b>	<b>85</b>	<b>1275</b>	<b>0</b>	<b>320</b>	<b>1720</b>	<b>0</b>	<b>0</b>	<b>0</b>	<b>0</b>	<b>546</b>	<b>1360</b>	<b>2040</b>	<b>0</b>	<b>405</b>	<b>1878</b>	<b>1663</b>	<b>0</b>	<b>3946</b>
SV	9	28	0	13	85	0	20	75	0	0	0	0	37	98	95	0	33	84	113	0	230
PV	145	350	0	66	1124	0	292	1595	0	0	0	0	495	1190	1887	0	358	1740	1474	0	3572
GV	13	38	0	19	151	0	28	125	0	0	0	0	51	170	153	0	47	138	189	0	374
<b>FZ-ART</b>	<b>1-2</b>	<b>1-3</b>	<b>1-4</b>	<b>2-1</b>	<b>2-3</b>	<b>2-4</b>	<b>3-1</b>	<b>3-2</b>	<b>3-4</b>	<b>4-1</b>	<b>4-2</b>	<b>4-3</b>	<b>Zu. 1</b>	<b>Zu. 2</b>	<b>Zu. 3</b>	<b>Zu. 4</b>	<b>Ab. 1</b>	<b>Ab. 2</b>	<b>Ab. 3</b>	<b>Ab. 4</b>	<b>K-Sum</b>

**Summe Zählintervall 15:00 Uhr - 19:00 Uhr**

FZ-ART	1-2	1-3	1-4	2-1	2-3	2-4	3-1	3-2	3-4	4-1	4-2	4-3	Zu. 1	Zu. 2	Zu. 3	Zu. 4	Ab. 1	Ab. 2	Ab. 3	Ab. 4	K-Sum
RAD	27	175	0	8	126	0	23	192	0	0	0	0	202	134	215	0	31	219	301	0	551
KRAD	4	24	0	5	84	0	15	87	0	0	0	0	28	89	102	0	20	91	108	0	219
PKW	61	441	0	122	1796	0	400	1925	0	0	0	0	502	1918	2325	0	522	1986	2237	0	4745
BUS	0	14	0	1	28	0	12	26	0	0	0	0	14	29	38	0	13	26	42	0	81
LFW	2	18	0	12	117	0	5	86	0	0	0	0	20	129	91	0	17	88	135	0	240
LKW	1	1	0	6	10	0	1	17	0	0	0	0	2	16	18	0	7	18	11	0	36
LZ	5	0	0	1	2	0	2	4	0	0	0	0	5	3	6	0	3	9	2	0	14
<b>KFZ</b>	<b>73</b>	<b>498</b>	<b>0</b>	<b>147</b>	<b>2037</b>	<b>0</b>	<b>435</b>	<b>2145</b>	<b>0</b>	<b>0</b>	<b>0</b>	<b>0</b>	<b>571</b>	<b>2184</b>	<b>2580</b>	<b>0</b>	<b>582</b>	<b>2218</b>	<b>2535</b>	<b>0</b>	<b>5335</b>
SV	6	15	0	8	40	0	15	47	0	0	0	0	21	48	62	0	23	53	55	0	131
PV	65	479	0	128	1908	0	427	2038	0	0	0	0	544	2036	2465	0	555	2103	2387	0	5045
GV	8	19	0	19	129	0	8	107	0	0	0	0	27	148	115	0	27	115	148	0	290
<b>FZ-ART</b>	<b>1-2</b>	<b>1-3</b>	<b>1-4</b>	<b>2-1</b>	<b>2-3</b>	<b>2-4</b>	<b>3-1</b>	<b>3-2</b>	<b>3-4</b>	<b>4-1</b>	<b>4-2</b>	<b>4-3</b>	<b>Zu. 1</b>	<b>Zu. 2</b>	<b>Zu. 3</b>	<b>Zu. 4</b>	<b>Ab. 1</b>	<b>Ab. 2</b>	<b>Ab. 3</b>	<b>Ab. 4</b>	<b>K-Sum</b>

**spezifische Spitzenstunde morgens 07:30 Uhr - 08:30 Uhr**

FZ-ART	1-2	1-3	1-4	2-1	2-3	2-4	3-1	3-2	3-4	4-1	4-2	4-3	Zu. 1	Zu. 2	Zu. 3	Zu. 4	Ab. 1	Ab. 2	Ab. 3	Ab. 4	K-Sum
RAD	24	24	0	66	24	0	88	53	0	0	0	0	48	90	141	0	154	77	48	0	279
KRAD	0	4	0	0	2	0	6	9	0	0	0	0	4	2	15	0	6	9	6	0	21
PKW	27	103	0	21	311	0	135	444	0	0	0	0	130	332	579	0	156	471	414	0	1041
BUS	0	5	0	0	15	0	4	15	0	0	0	0	5	15	19	0	4	15	20	0	39
LFW	0	8	0	4	40	0	11	28	0	0	0	0	8	44	39	0	15	28	48	0	91
LKW	0	0	0	2	6	0	1	6	0	0	0	0	0	8	7	0	3	6	6	0	15
LZ	1	0	0	1	3	0	1	3	0	0	0	0	1	4	4	0	2	4	3	0	9
<b>KFZ</b>	<b>28</b>	<b>120</b>	<b>0</b>	<b>28</b>	<b>377</b>	<b>0</b>	<b>158</b>	<b>505</b>	<b>0</b>	<b>0</b>	<b>0</b>	<b>0</b>	<b>148</b>	<b>405</b>	<b>663</b>	<b>0</b>	<b>186</b>	<b>533</b>	<b>497</b>	<b>0</b>	<b>1216</b>
SV	1	5	0	3	24	0	6	24	0	0	0	0	6	27	30	0	9	25	29	0	63
PV	27	112	0	21	328	0	145	468	0	0	0	0	139	349	613	0	166	495	440	0	1101
GV	1	8	0	7	49	0	13	37	0	0	0	0	9	56	50	0	20	38	57	0	115
<b>FZ-ART</b>	<b>1-2</b>	<b>1-3</b>	<b>1-4</b>	<b>2-1</b>	<b>2-3</b>	<b>2-4</b>	<b>3-1</b>	<b>3-2</b>	<b>3-4</b>	<b>4-1</b>	<b>4-2</b>	<b>4-3</b>	<b>Zu. 1</b>	<b>Zu. 2</b>	<b>Zu. 3</b>	<b>Zu. 4</b>	<b>Ab. 1</b>	<b>Ab. 2</b>	<b>Ab. 3</b>	<b>Ab. 4</b>	<b>K-Sum</b>

**spezifische Spitzenstunde abends 16:45 Uhr - 17:45 Uhr**

FZ-ART	1-2	1-3	1-4	2-1	2-3	2-4	3-1	3-2	3-4	4-1	4-2	4-3	Zu. 1	Zu. 2	Zu. 3	Zu. 4	Ab. 1	Ab. 2	Ab. 3	Ab. 4	K-Sum
RAD	5	50	0	2	34	0	2	37	0	0	0	0	55	36	39	0	4	42	84	0	130
KRAD	0	6	0	2	26	0	3	21	0	0	0	0	6	28	24	0	5	21	32	0	58
PKW	18	126	0	23	483	0	111	521	0	0	0	0	144	506	632	0	134	539	609	0	1282
BUS	0	3	0	0	7	0	3	4	0	0	0	0	3	7	7	0	3	4	10	0	17
LFW	0	5	0	3	32	0	0	20	0	0	0	0	5	35	20	0	3	20	37	0	60
LKW	0	1	0	0	2	0	0	1	0	0	0	0	1	2	1	0	0	1	3		



# Stadt Dachau

Zählstelle: K56 Schleißheimer Straße / Friedenstraße

Zusammenfassung Stundengruppen

Zähltag: Do., 08.05.2008

Zählzeit: 06:00 Uhr - 10:00 Uhr und 15:00 Uhr - 19:00 Uhr

Zu-/Ablauf 1: Friedenstr.

Zu-/Ablauf 2: Schleißheimer Str. (von/nach Stadtauswärts)

Zu-/Ablauf 3: Schleißheimer Str. (von/nach Stadteinwärts)

Spezifische Spitzenstunde morgens  
07:30 Uhr - 08:30 Uhr in KFZ

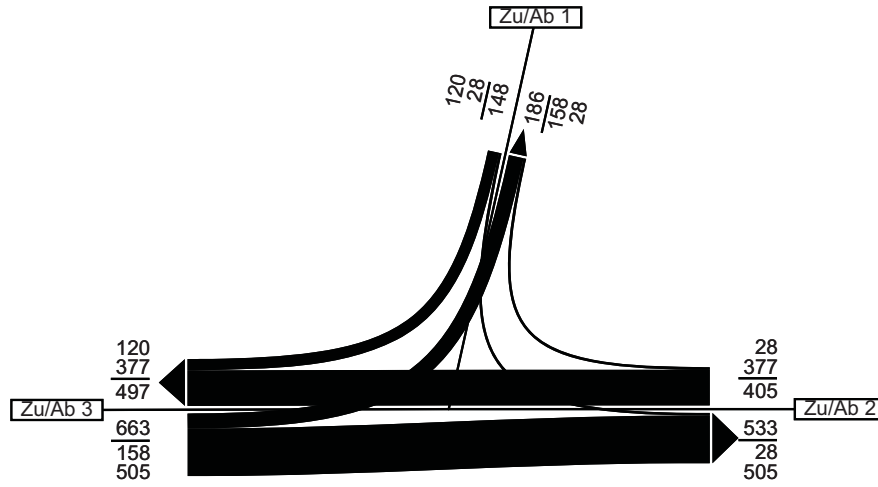

Spezifische Spitzenstunde abends  
16:45 Uhr - 17:45 Uhr in KFZ

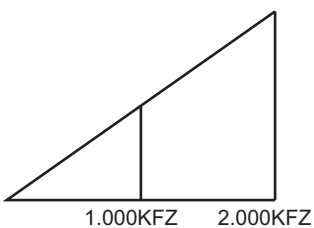
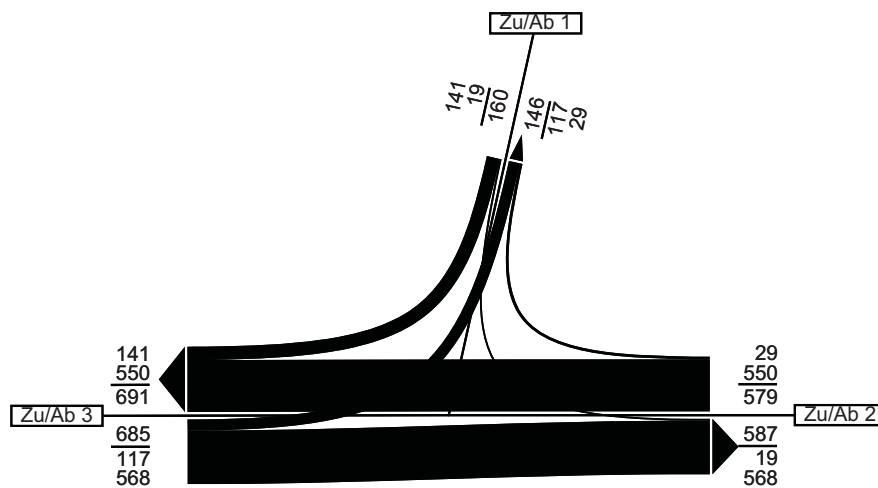

### Stadt Dachau

Zählstelle: K57 Schillerstraße / Gröbenrieder Straße

Zu-/Ablauf 1: Schillerstr. (von/nach Stadteinwärts)  
Zu-/Ablauf 2: Gröbenrieder Str. (von/nach Stadtauswärts)  
Zu-/Ablauf 3: Schillerstr. (von/nach Stadtauswärts)  
Zu-/Ablauf 4: Gröbenrieder Str. (von/nach Stadteinwärts)

Zusammenfassung Stundengruppen

Zähltag: Do., 08.05.2008  
Zählzeit: 06:00 Uhr - 10:00 Uhr und 15:00 Uhr - 19:00 Uhr

#### Summe Zählzeit (06:00 Uhr - 10:00 Uhr und 15:00 Uhr - 19:00 Uhr)

FZ-ART	1-2	1-3	1-4	2-1	2-3	2-4	3-1	3-2	3-4	4-1	4-2	4-3	Zu. 1	Zu. 2	Zu. 3	Zu. 4	Ab. 1	Ab. 2	Ab. 3	Ab. 4	K-Sum
RAD	23	134	7	31	1	10	240	5	7	2	16	4	164	42	252	22	273	44	139	24	480
KRAD	30	78	6	35	0	4	65	3	5	2	7	1	114	39	73	10	102	40	79	15	236
PKW	925	2522	93	1029	41	153	2481	67	104	73	95	127	3540	1223	2652	296	3583	1087	2690	350	7710
BUS	7	48	0	11	0	0	54	0	0	0	0	1	55	11	54	1	65	7	49	0	121
LFW	46	127	1	64	1	6	173	10	2	0	11	5	174	71	185	16	237	67	133	9	446
LKW	8	48	0	8	6	1	63	5	0	0	0	1	56	15	68	1	71	13	55	1	140
LZ	11	15	1	6	2	1	10	7	0	0	0	0	27	9	17	0	16	18	17	2	53
KFZ	1027	2838	101	1153	50	165	2846	92	111	75	113	135	3966	1368	3049	323	4074	1232	3023	377	8706
SV	26	111	1	25	8	2	127	12	0	0	0	2	138	35	139	2	152	38	121	3	314
PV	962	2648	99	1075	41	157	2600	70	109	75	102	129	3709	1273	2779	306	3750	1134	2818	365	8067
GV	65	190	2	78	9	8	246	22	2	0	11	6	257	95	270	17	324	98	205	12	639
FZ-ART	1-2	1-3	1-4	2-1	2-3	2-4	3-1	3-2	3-4	4-1	4-2	4-3	Zu. 1	Zu. 2	Zu. 3	Zu. 4	Ab. 1	Ab. 2	Ab. 3	Ab. 4	K-Sum

#### Summe Zählintervall 06:00 Uhr - 10:00 Uhr

FZ-ART	1-2	1-3	1-4	2-1	2-3	2-4	3-1	3-2	3-4	4-1	4-2	4-3	Zu. 1	Zu. 2	Zu. 3	Zu. 4	Ab. 1	Ab. 2	Ab. 3	Ab. 4	K-Sum
RAD	1	29	0	17	1	3	127	0	2	2	3	1	30	21	129	6	146	4	31	5	186
KRAD	6	7	1	12	0	3	29	2	3	0	3	0	14	15	34	3	41	11	7	7	66
PKW	288	754	36	481	5	53	1488	31	48	37	32	30	1078	539	1567	99	2006	351	789	137	3283
BUS	7	28	0	9	0	0	34	0	0	0	0	1	35	9	34	1	43	7	29	0	79
LFW	17	59	0	28	1	3	73	4	2	0	4	3	76	32	79	7	101	25	63	5	194
LKW	4	24	0	7	2	0	42	3	0	0	0	1	28	9	45	1	49	7	27	0	83
LZ	11	5	1	3	0	0	6	7	0	0	0	0	17	3	13	0	9	18	5	1	33
KFZ	333	877	38	540	8	59	1672	47	53	37	39	35	1248	607	1772	111	2249	419	920	150	3738
SV	22	57	1	19	2	0	82	10	0	0	0	2	80	21	92	2	101	32	61	1	195
PV	301	789	37	502	5	56	1551	33	51	37	35	31	1127	563	1635	103	2090	369	825	144	3428
GV	32	88	1	38	3	3	121	14	2	0	4	4	121	44	137	8	159	50	95	6	310
FZ-ART	1-2	1-3	1-4	2-1	2-3	2-4	3-1	3-2	3-4	4-1	4-2	4-3	Zu. 1	Zu. 2	Zu. 3	Zu. 4	Ab. 1	Ab. 2	Ab. 3	Ab. 4	K-Sum

#### Summe Zählintervall 15:00 Uhr - 19:00 Uhr

FZ-ART	1-2	1-3	1-4	2-1	2-3	2-4	3-1	3-2	3-4	4-1	4-2	4-3	Zu. 1	Zu. 2	Zu. 3	Zu. 4	Ab. 1	Ab. 2	Ab. 3	Ab. 4	K-Sum
RAD	22	105	7	14	0	7	113	5	5	0	13	3	134	21	123	16	127	40	108	19	294
KRAD	24	71	5	23	0	1	36	1	2	2	4	1	100	24	39	7	61	29	72	8	170
PKW	637	1768	57	548	36	100	993	36	56	36	63	97	2462	684	1085	196	1577	736	1901	213	4427
BUS	0	20	0	2	0	0	20	0	0	0	0	0	20	2	20	0	22	0	20	0	42
LFW	29	68	1	36	0	3	100	6	0	0	7	2	98	39	106	9	136	42	70	4	252
LKW	4	24	0	1	4	1	21	2	0	0	0	0	28	6	23	0	22	6	28	1	57
LZ	0	10	0	3	2	1	4	0	0	0	0	0	10	6	4	0	7	0	12	1	20
KFZ	694	1961	63	613	42	106	1174	45	58	38	74	100	2718	761	1277	212	1825	813	2103	227	4968
SV	4	54	0	6	6	2	45	2	0	0	0	1	58	14	47	0	51	6	60	2	119
PV	661	1859	62	573	36	101	1049	37	58	38	67	98	2582	710	1144	203	1660	765	1993	221	4639
GV	33	102	1	40	6	5	125	8	0	0	7	2	136	51	133	9	165	48	110	6	329
FZ-ART	1-2	1-3	1-4	2-1	2-3	2-4	3-1	3-2	3-4	4-1	4-2	4-3	Zu. 1	Zu. 2	Zu. 3	Zu. 4	Ab. 1	Ab. 2	Ab. 3	Ab. 4	K-Sum

#### spezifische Spitzenstunde morgens 07:15 Uhr - 08:15 Uhr

FZ-ART	1-2	1-3	1-4	2-1	2-3	2-4	3-1	3-2	3-4	4-1	4-2	4-3	Zu. 1	Zu. 2	Zu. 3	Zu. 4	Ab. 1	Ab. 2	Ab. 3	Ab. 4	K-Sum
RAD	0	4	0	5	0	2	52	0	1	0	0	0	4	7	53	0	57	0	4	3	64
KRAD	1	2	0	4	0	0	11	0	3	0	3	0	3	4	14	3	15	4	2	3	24
PKW	76	239	8	129	1	24	492	6	12	12	7	5	323	154	510	24	633	89	245	44	1011
BUS	4	8	0	1	0	0	13	0	0	0	0	0	12	1	13	0	14	4	8	0	26
LFW	9	18	0	5	1	1	29	0	1	0	1	1	27	7	30	2	34	10	20	2	66
LKW	0	3	0	4	0	0	10	1	0	0	0	1	3	4	11	1	14	1	4	0	19
LZ	4	1	1	1	0	0	2	2	0	0	0	0	6	1	4	0	3	6	1	1	11
KFZ	94	271	9	144	2	25	557	9	16	12	11	7	374	171	582	30	713	114	280	50	1157
SV	8	12	1	6	0	0	25	3	0	0	0	1	21	6	28	1	31	11	13	1	56
PV	81	249	8	134	1	24	516	6	15	12	10	5	338	159	537	27	662	97	255	47	1061
GV	13	22	1	10	1	1	41	3	1	0	1	2	36	12	45	3	51	17	25	3	96
FZ-ART	1-2	1-3	1-4	2-1	2-3	2-4	3-1	3-2	3-4	4-1	4-2	4-3	Zu. 1	Zu. 2	Zu. 3	Zu. 4	Ab. 1	Ab. 2	Ab. 3	Ab. 4	K-Sum

#### spezifische Spitzenstunde abends 16:30 Uhr - 17:30 Uhr

FZ-ART	1-2	1-3	1-4	2-1	2-3	2-4	3-1	3-2	3-4	4-1	4-2	4-3	Zu. 1	Zu. 2	Zu. 3	Zu. 4	Ab. 1	Ab. 2	Ab. 3	Ab. 4	K-Sum
RAD	5	25	1	3	0	1	23	4	2	0	3	3	31	4	29	6	26	12	28	4	70
KRAD	7	19	4	9	0	0	11	1	0	2	1	0	30	9	12	3	22	9	19	4	54
PKW	171	478	8	164	9	19	338	11	15	12	24	28	657	192	364	64	514	206	515	42	1277
BUS	0	3	0	1	0	0	5	0	0	0	0	0	3	1	5	0	6	0	3	0	9
LFW	8	11	1	12	0	0	24	2	0	0	2	0	20	12	26	2	36	12	11	1	60
LKW	1	5	0	0	0	1	3	0	0	0	0	0	6	1	3	0	3	1	5	1	10
LZ	0	3	0	0	0	0	0	0	0	0	0	0	3	0	0	0	0	0	3	0	3
KFZ	187	519	13	186	9	20	381	14	15	14	27	28	719	215	410	69	581	228	556	48	1413
SV	1	11	0	1	0	1	8	0	0	0	0	0	12	2	8	0	9	1	11	1	22
PV	178	500	12	174	9	19	354	12	15	14	25	28	690	202	381	67	542	215	537	46	1340
GV	9	19	1	12	0	1	27	2	0	0	2	0	29	13	29	2	39	13	19	2	73
FZ-ART	1-2	1-3	1-4	2-1	2-3	2-4	3-1	3-2	3-4	4-1	4-2	4-3	Zu. 1	Zu. 2	Zu. 3	Zu. 4	Ab. 1	Ab. 2	Ab. 3	Ab. 4	K-Sum

#### Erläuterungen:

RAD = Fahrrad

KRAD = Kraftrad

PKW = Personenkraftwagen

BUS = Linien-/ Reisebus (mehr als 9 Insassen)

LFW = Lieferwagen

LKW = Lastkraftwagen (> 2.8t)

LZ = Lastzug / Sonderfahrzeuge

KFZ = Kraftfahrzeuge (KRAD+PKW+BUS+LFW+LKW+LZ)

SV = Schwerverkehr (BUS+LKW+LZ)

PV = Personenverkehr (KRAD+PKW+BUS)

GV = Güterverkehr (LFW+LKW+LZ)

# Stadt Dachau

Zählstelle: K57 Schillerstraße / Gröbenrieder Straße

Zusammenfassung Stundengruppen

Zähltag: Do., 08.05.2008

Zählzeit: 06:00 Uhr - 10:00 Uhr und 15:00 Uhr - 19:00 Uhr

Zu-/Ablauf 1: Schillerstr. (von/nach Stadteinwärts)

Zu-/Ablauf 2: Gröbenrieder Str. (von/nach Stadtauswärts)

Zu-/Ablauf 3: Schillerstr. (von/nach Stadtauswärts)

Zu-/Ablauf 4: Gröbenrieder Str. (von/nach Stadteinwärts)

Spezifische Spitzenstunde morgens  
07:15 Uhr - 08:15 Uhr in KFZ

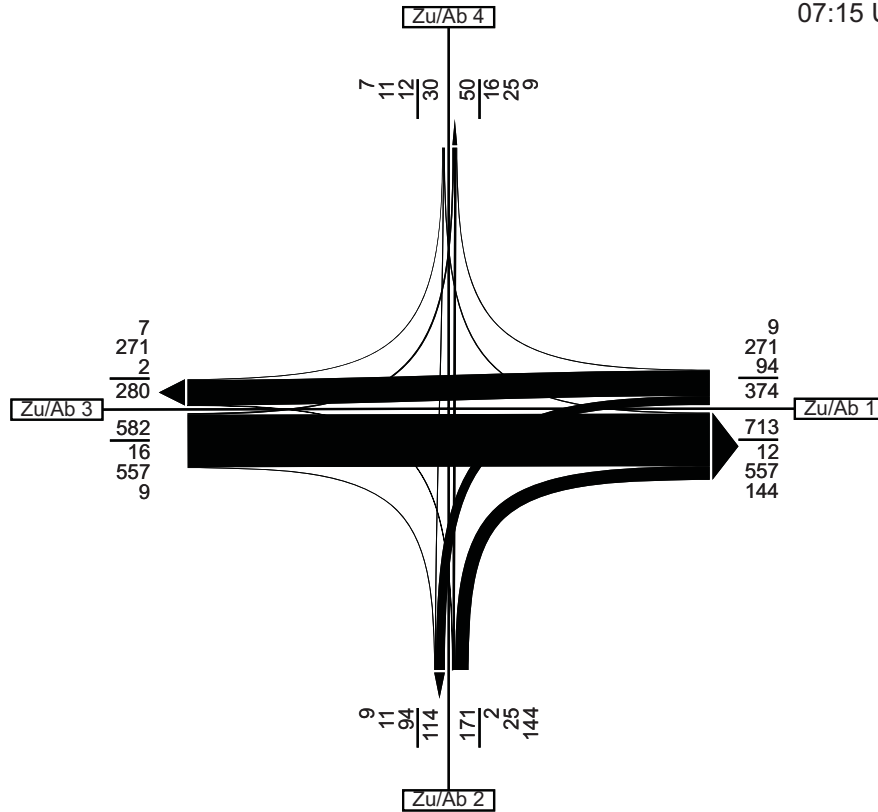

Spezifische Spitzenstunde abends  
16:30 Uhr - 17:30 Uhr in KFZ

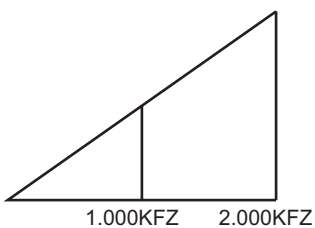
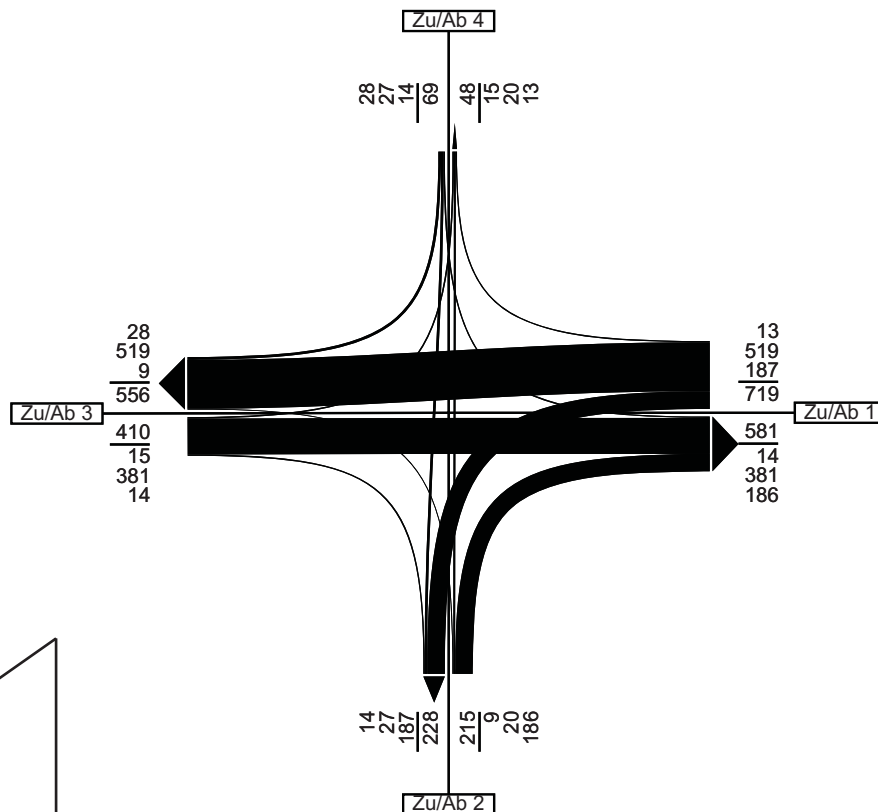

# Stadt Dachau

Zählstelle: K58 Schillerstraße / Uhdestraße

Zu-/Ablauf 1: Schillerstr. (von/nach Stadteinwärts)  
Zu-/Ablauf 2: Uhdestr. (von/nach Stadtauswärts)  
Zu-/Ablauf 3: Schillerstr. (von/nach Stadtauswärts)  
Zu-/Ablauf 4: Uhdestr. (von/nach Stadteinwärts)

Zusammenfassung Stundengruppen

Zähltag: Do., 08.05.2008

Zählzeit: 06:00 Uhr - 10:00 Uhr und 15:00 Uhr - 19:00 Uhr

## Summe Zählzeit (06:00 Uhr - 10:00 Uhr und 15:00 Uhr - 19:00 Uhr)

FZ-ART	1-2	1-3	1-4	2-1	2-3	2-4	3-1	3-2	3-4	4-1	4-2	4-3	Zu. 1	Zu. 2	Zu. 3	Zu. 4	Ab. 1	Ab. 2	Ab. 3	Ab. 4	K-Sum
RAD	22	110	7	27	14	64	221	51	2	4	73	3	139	105	274	80	252	146	127	73	598
KRAD	3	74	2	4	9	5	69	15	0	0	1	0	79	18	84	0	73	19	83	7	182
PKW	138	2527	25	101	496	71	2543	469	30	8	52	8	2690	668	3042	68	2652	659	3031	126	6468
BUS	0	49	0	0	1	0	54	2	0	0	0	0	49	1	56	0	54	2	50	0	106
LFW	8	122	3	7	35	8	178	33	1	0	1	2	133	50	212	3	185	42	159	12	398
LKW	2	53	0	0	1	0	68	1	0	0	0	0	55	1	69	0	68	3	54	0	125
LZ	0	17	0	0	2	2	17	2	0	0	0	0	17	4	19	0	17	2	19	2	40
<b>KFZ</b>	<b>151</b>	<b>2842</b>	<b>30</b>	<b>112</b>	<b>544</b>	<b>86</b>	<b>2929</b>	<b>522</b>	<b>31</b>	<b>8</b>	<b>54</b>	<b>10</b>	<b>3023</b>	<b>742</b>	<b>3482</b>	<b>72</b>	<b>3049</b>	<b>727</b>	<b>3396</b>	<b>147</b>	<b>7319</b>
SV	2	119	0	0	4	2	139	5	0	0	0	0	121	6	144	0	139	7	123	2	271
PV	141	2650	27	105	506	76	2666	486	30	8	53	8	2818	687	3182	69	2779	680	3164	133	6756
GV	10	192	3	7	38	10	263	36	1	0	1	2	205	55	300	3	270	47	232	14	563
<b>FZ-ART</b>	<b>1-2</b>	<b>1-3</b>	<b>1-4</b>	<b>2-1</b>	<b>2-3</b>	<b>2-4</b>	<b>3-1</b>	<b>3-2</b>	<b>3-4</b>	<b>4-1</b>	<b>4-2</b>	<b>4-3</b>	<b>Zu. 1</b>	<b>Zu. 2</b>	<b>Zu. 3</b>	<b>Zu. 4</b>	<b>Ab. 1</b>	<b>Ab. 2</b>	<b>Ab. 3</b>	<b>Ab. 4</b>	<b>K-Sum</b>

## Summe Zählintervall 06:00 Uhr - 10:00 Uhr

FZ-ART	1-2	1-3	1-4	2-1	2-3	2-4	3-1	3-2	3-4	4-1	4-2	4-3	Zu. 1	Zu. 2	Zu. 3	Zu. 4	Ab. 1	Ab. 2	Ab. 3	Ab. 4	K-Sum
RAD	4	25	2	24	10	27	102	17	1	3	22	1	31	61	120	26	129	43	36	30	238
KRAD	0	7	0	1	1	1	33	10	0	0	0	0	7	3	43	0	34	10	8	1	53
PKW	54	728	7	42	123	30	1520	227	22	5	16	5	789	195	1769	26	1567	297	856	59	2779
BUS	0	29	0	0	1	0	34	1	0	0	0	0	29	1	35	0	34	1	30	0	65
LFW	8	53	2	4	8	3	75	21	1	0	1	1	63	15	97	2	79	30	62	6	177
LKW	2	25	0	0	1	0	45	1	0	0	0	0	27	1	46	0	45	3	26	0	74
LZ	0	5	0	0	2	2	13	1	0	0	0	0	5	4	14	0	13	1	7	2	23
<b>KFZ</b>	<b>64</b>	<b>847</b>	<b>9</b>	<b>47</b>	<b>136</b>	<b>36</b>	<b>1720</b>	<b>261</b>	<b>23</b>	<b>5</b>	<b>17</b>	<b>6</b>	<b>920</b>	<b>219</b>	<b>2004</b>	<b>28</b>	<b>1772</b>	<b>342</b>	<b>989</b>	<b>68</b>	<b>3171</b>
SV	2	59	0	0	4	2	92	3	0	0	0	0	61	6	95	0	92	5	63	2	162
PV	54	764	7	43	125	31	1587	238	22	5	16	5	825	199	1847	26	1635	308	894	60	2897
GV	10	83	2	4	11	5	133	23	1	0	1	1	95	20	157	2	137	34	95	8	274
<b>FZ-ART</b>	<b>1-2</b>	<b>1-3</b>	<b>1-4</b>	<b>2-1</b>	<b>2-3</b>	<b>2-4</b>	<b>3-1</b>	<b>3-2</b>	<b>3-4</b>	<b>4-1</b>	<b>4-2</b>	<b>4-3</b>	<b>Zu. 1</b>	<b>Zu. 2</b>	<b>Zu. 3</b>	<b>Zu. 4</b>	<b>Ab. 1</b>	<b>Ab. 2</b>	<b>Ab. 3</b>	<b>Ab. 4</b>	<b>K-Sum</b>

## Summe Zählintervall 15:00 Uhr - 19:00 Uhr

FZ-ART	1-2	1-3	1-4	2-1	2-3	2-4	3-1	3-2	3-4	4-1	4-2	4-3	Zu. 1	Zu. 2	Zu. 3	Zu. 4	Ab. 1	Ab. 2	Ab. 3	Ab. 4	K-Sum
RAD	18	85	5	3	4	37	119	34	1	1	51	2	108	44	154	54	123	103	91	43	360
KRAD	3	67	2	3	8	4	36	5	0	0	1	0	72	15	41	1	39	9	75	6	129
PKW	84	1799	18	59	373	41	1023	242	8	3	36	3	1901	473	1273	42	1085	362	2175	67	3689
BUS	0	20	0	0	0	0	20	1	0	0	0	0	20	0	21	0	20	1	20	0	41
LFW	0	69	1	3	27	5	103	12	0	0	0	1	70	35	115	1	106	12	97	6	221
LKW	0	28	0	0	0	0	23	0	0	0	0	0	28	0	23	0	23	0	28	0	51
LZ	0	12	0	0	0	0	4	1	0	0	0	0	12	0	5	0	4	1	12	0	17
<b>KFZ</b>	<b>87</b>	<b>1995</b>	<b>21</b>	<b>65</b>	<b>408</b>	<b>50</b>	<b>1209</b>	<b>261</b>	<b>8</b>	<b>3</b>	<b>37</b>	<b>4</b>	<b>2103</b>	<b>523</b>	<b>1478</b>	<b>44</b>	<b>1277</b>	<b>385</b>	<b>2407</b>	<b>79</b>	<b>4148</b>
SV	0	60	0	0	0	0	47	2	0	0	0	0	60	0	49	0	47	2	60	0	109
PV	87	1886	20	62	381	45	1079	248	8	3	37	3	1993	488	1335	43	1144	372	2270	73	3859
GV	0	109	1	3	27	5	130	13	0	0	0	1	110	35	143	1	133	13	137	6	289
<b>FZ-ART</b>	<b>1-2</b>	<b>1-3</b>	<b>1-4</b>	<b>2-1</b>	<b>2-3</b>	<b>2-4</b>	<b>3-1</b>	<b>3-2</b>	<b>3-4</b>	<b>4-1</b>	<b>4-2</b>	<b>4-3</b>	<b>Zu. 1</b>	<b>Zu. 2</b>	<b>Zu. 3</b>	<b>Zu. 4</b>	<b>Ab. 1</b>	<b>Ab. 2</b>	<b>Ab. 3</b>	<b>Ab. 4</b>	<b>K-Sum</b>

## spezifische Spitzenstunde morgens 07:15 Uhr - 08:15 Uhr

FZ-ART	1-2	1-3	1-4	2-1	2-3	2-4	3-1	3-2	3-4	4-1	4-2	4-3	Zu. 1	Zu. 2	Zu. 3	Zu. 4	Ab. 1	Ab. 2	Ab. 3	Ab. 4	K-Sum
RAD	0	4	0	9	4	16	44	6	1	0	11	0	4	29	51	11	53	17	8	17	95
KRAD	0	2	0	1	0	1	13	3	0	0	0	0	2	2	16	0	14	3	2	1	20
PKW	13	232	0	13	40	10	497	76	12	0	6	0	245	63	585	6	510	95	272	22	899
BUS	0	8	0	0	0	0	13	1	0	0	0	0	8	0	14	0	13	1	8	0	22
LFW	2	18	0	1	5	2	29	8	1	0	0	1	20	8	38	1	30	10	24	3	67
LKW	0	4	0	0	0	0	11	0	0	0	0	0	4	0	11	0	11	0	4	0	15
LZ	0	1	0	0	1	1	4	0	0	0	0	0	1	2	4	0	4	0	2	1	7
<b>KFZ</b>	<b>15</b>	<b>265</b>	<b>0</b>	<b>15</b>	<b>46</b>	<b>14</b>	<b>567</b>	<b>88</b>	<b>13</b>	<b>0</b>	<b>6</b>	<b>1</b>	<b>280</b>	<b>75</b>	<b>668</b>	<b>7</b>	<b>582</b>	<b>109</b>	<b>312</b>	<b>27</b>	<b>1030</b>
SV	0	13	0	0	1	1	28	1	0	0	0	0	13	2	29	0	28	1	14	1	44
PV	13	242	0	14	40	11	523	80	12	0	6	0	255	65	615	6	537	99	282	23	941
GV	2	23	0	1	6	3	44	8	1	0	0	1	25	10	53	1	45	10	30	4	89
<b>FZ-ART</b>	<b>1-2</b>	<b>1-3</b>	<b>1-4</b>	<b>2-1</b>	<b>2-3</b>	<b>2-4</b>	<b>3-1</b>	<b>3-2</b>	<b>3-4</b>	<b>4-1</b>	<b>4-2</b>	<b>4-3</b>	<b>Zu. 1</b>	<b>Zu. 2</b>	<b>Zu. 3</b>	<b>Zu. 4</b>	<b>Ab. 1</b>	<b>Ab. 2</b>	<b>Ab. 3</b>	<b>Ab. 4</b>	<b>K-Sum</b>

## spezifische Spitzenstunde abends 16:15 Uhr - 17:15 Uhr

FZ-ART	1-2	1-3	1-4	2-1	2-3	2-4	3-1	3-2	3-4	4-1	4-2	4-3	Zu. 1	Zu. 2	Zu. 3	Zu. 4	Ab. 1	Ab. 2	Ab. 3	Ab. 4	K-Sum
RAD	5	26	0	0	0	11	31	13	0	0	9	1	31	11	44	10	31	27	27	11	96
KRAD	0	19	0	0	0	1	13	0	0	0	0	0	19	1	13	0	13	0	19	1	33
PKW	27	477	5	14	113	10	351	70	1	0	6	1	509	137	422	7	365	103	591	16	1075
BUS	0	3	0	0	0	0	3	0	0	0	0	0	3	0	3	0	3	0	3	0	6
LFW	0	11	0	1	12	3	19	2	0	0	0	1	11	16	21	1	20	2	24	3	49
LKW	0	8	0	0	0	0	3	0	0	0	0	0	8	0	3	0	3	0	8	0	11
LZ	0	2	0	0	0	0	0	1	0	0	0	0	2	0	1	0	0	1	2	0	3
<b>KFZ</b>	<b>27</b>	<b>520</b>	<b>5</b>	<b>15</b>	<b>125</b>	<b>14</b>	<b>389</b>	<b>73</b>	<b>1</b>	<b>0</b>	<b>6</b>	<b>2</b>	<b>552</b>	<b>154</b>	<b>463</b>	<b>8</b>	<b>404</b>	<b>106</b>	<b>647</b>	<b>20</b>	<b>1177</b>
SV	0	13	0	0	0	0	6	1	0	0	0	0	13	0	7	0	6	1	13	0	20
PV	27	499	5	14	113	11	367	70	1	0	6	1	531	138	438	7	381	103	613	17	1114
GV	0	21	0	1	12	3	22	3	0	0	0	1	21	16	25	1	23	3	34	3	63
<b>FZ-ART</b>	<b>1-2</b>	<b>1-3</b>	<b>1-4</b>	<b>2-1</b>	<b>2-3</b>	<b>2-4</b>	<b>3-1</b>	<b>3-2</b>	<b>3-4</b>	<b>4-1</b>	<b>4-2</b>	<b>4-3</b>	<b>Zu. 1</b>	<b>Zu. 2</b>	<b>Zu. 3</b>	<b>Zu. 4</b>	<b>Ab. 1</b>	<b>Ab. 2</b>	<b>Ab. 3</b>	<b>Ab. 4</b>	<b>K-Sum</b>

### Erläuterungen:

RAD = Fahrrad

KRAD = Kraftrad

PKW = Personenkraftwagen

BUS = Linien-/ Reisebus (mehr als 9 Insassen)

LFW = Lieferwagen

LKW = Lastkraftwagen (> 2.8t)

LZ = Lastzug / Sonderfahrzeuge

KFZ = Kraftfahrzeuge (KRAD+PKW+BUS+LFW+LKW+LZ)

SV = Schwerverkehr (BUS+LKW+

# Stadt Dachau

Zählstelle: K58 Schillerstraße / Uhdestraße

Zusammenfassung Stundengruppen

Zähltag: Do., 08.05.2008

Zählzeit: 06:00 Uhr - 10:00 Uhr und 15:00 Uhr - 19:00 Uhr

Zu-/Ablauf 1: Schillerstr. (von/nach Stadteinwärts)

Zu-/Ablauf 2: Uhdestr. (von/nach Stadtauswärts)

Zu-/Ablauf 3: Schillerstr. (von/nach Stadtauswärts)

Zu-/Ablauf 4: Uhdestr. (von/nach Stadteinwärts)

Spezifische Spitzenstunde morgens  
07:15 Uhr - 08:15 Uhr in KFZ

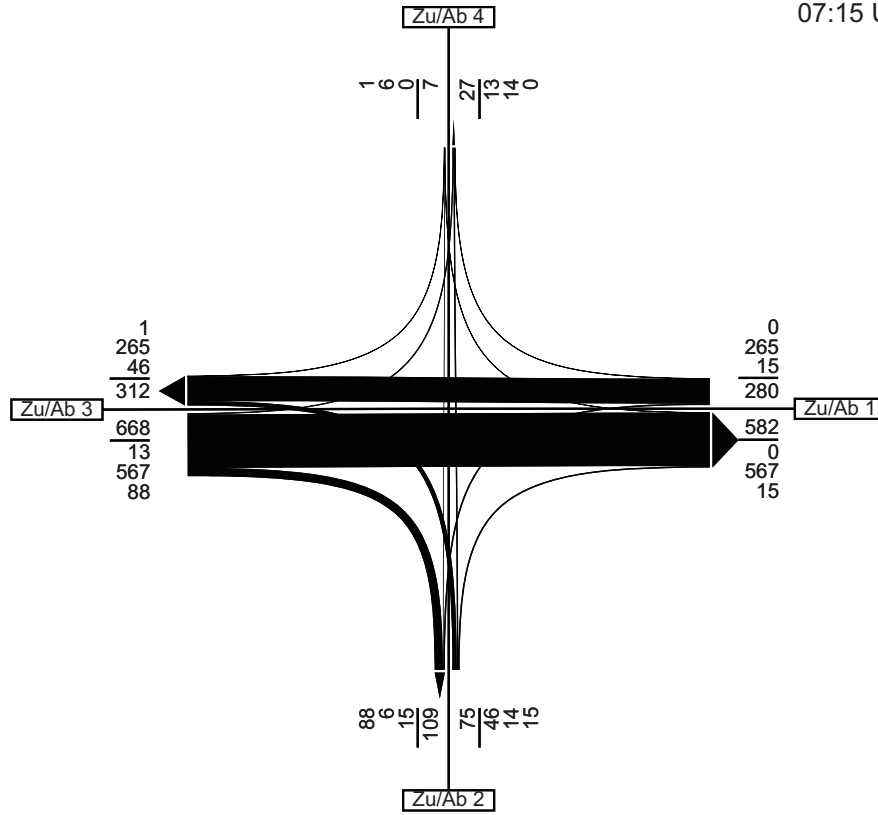

Spezifische Spitzenstunde abends  
16:30 Uhr - 17:30 Uhr in KFZ

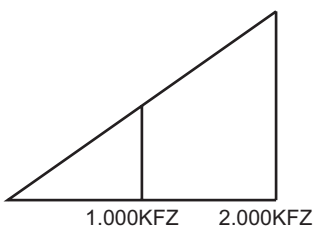
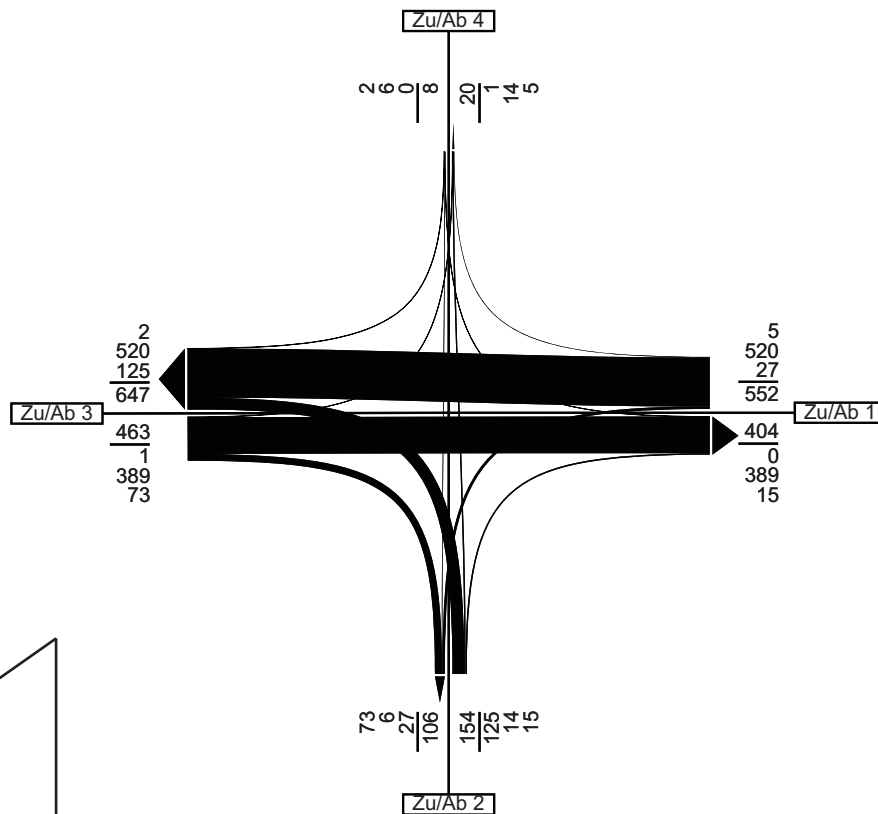



**GROSSE KREISSTADT DACHAU**

**Verkehrserhebungen 2007/2008**

Querschnittsbelastungen in KFZ/24h  
(vorläufige Hochrechnung auf Basis  
nicht gesicherter Faktoren)

Verkehrserhebungen durchgeführt im II. Quartal 2007  
und II. Quartal 2008

Stand: Mai 2008

